

HOFMANN & VRATNY — EXN1 SERIES EN

EXN1 SERIES



Expert

2022





HOFMANN & VRATNY — EXPERTS IN CUTTING NON-FERROUS MATERIALS

OUR EXN1 SERIES

THE RIGHT MILLING CUTTER. AT ALL TIMES.

Welcome to Hofmann & Vratny. As the leading manufacturer of solid carbide milling cutters, we enable companies throughout the world to manufacture their products.

Every day, our strong team works on our collective goal of producing the best milling cutters in the world. Companies from the medical industry, semiconductor industry, machine and plant construction, aviation, aerospace engineering and, not least, the automotive industry have been using our milling cutters for many years now. Quality - Made in Bavaria.

The success of our company is built on innovation, a culture of cooperation, open dealings on an equal footing and many years of successful and trustful collaboration with our business partners. You can count on us, our milling cutters and our irrepressible drive to shape the future of the industry together. To us, that means shaping tomorrow.

Andreas Vratny

Zdenek Vratny

Marius Heinemann-Grüder



OUR
EXN1 Series



46
YEARS OF
EXPERIENCE

2 Mio.
MILLING
CUTTERS
PRODUCED
EVERY YEAR

MADE IN BAVARIA

Our milling cutters are used by companies all over the world. Still they all have the same origin: Our production sites in Bavaria, Germany.

As a traditional company, we are proud of our strong connection to the region. Ever since we were founded, we have been firmly tied to our homeland, and our team works on producing the best milling cutters in the world in a familial environment. Genuine quality work, the highest-quality craftsmanship and a strong promotion and retention of our talent: This is what Made in Bavaria means to us.

MADE IN
BAVARIA

PROVEN QUALITY



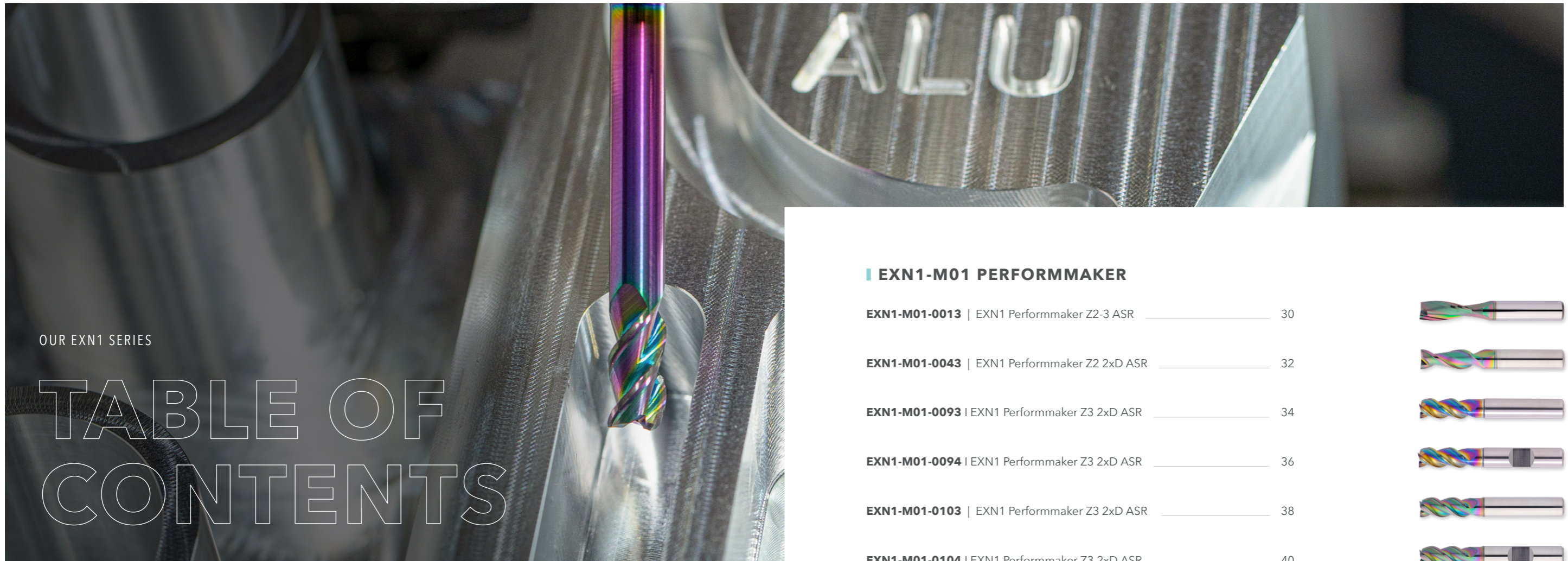

OUR EXN1 SERIES

TABLE OF CONTENTS

OUR EXN1 SERIES	12
THE EXN1 SERIES AT A GLANCE	14
THE EXN1 SERIES IN OPERATION	23
ALPHASLIDE RAINBOW - OUR NEW COATING MADE OF TETRAGONAL CARBON	24
DETAILED COATING COMPARISON	26
DIGITAL SERVICES	28
NUMBERING SYSTEM	29

EXN1-M01 PERFORMMAKER

EXN1-M01-0013 EXN1 Performmaker Z2-3 ASR	30
EXN1-M01-0043 EXN1 Performmaker Z2 2xD ASR	32
EXN1-M01-0093 EXN1 Performmaker Z3 2xD ASR	34
EXN1-M01-0094 EXN1 Performmaker Z3 2xD ASR	36
EXN1-M01-0103 EXN1 Performmaker Z3 2xD ASR	38
EXN1-M01-0104 EXN1 Performmaker Z3 2xD ASR	40
EXN1-M01-0113 EXN1 Performmaker Z3 1.5xD long ASR	42
EXN1-M01-0114 EXN1 Performmaker Z3 1.5xD long ASR	44
EXN1-M01-0123 EXN1 Performmaker Z3 3xD ASR	46
EXN1-M01-0124 EXN1 Performmaker Z3 3xD ASR	48
EXN1-M01-0133 EXN1 Performmaker Z3 3xD ASR	50
EXN1-M01-0134 EXN1 Performmaker Z3 3xD ASR	52
EXN1-M01-0203 EXN1 Performmaker Z3 2xD IC ASR	54
EXN1-M01-0204 EXN1 Performmaker Z3 2xD IC ASR	56



EXN1-M01 PERFORMMAKER

EXN1-M01-0213 | EXN1 Performmaker Z3 1.5xD long IC ASR _____ 58

EXN1-M01-0214 | EXN1 Performmaker Z3 1.5xD long IC ASR _____ 60

EXN1-M01-0293 | EXN1 Performmaker Z4 2xD ASR _____ 62

EXN1-M01-0294 | EXN1 Performmaker Z4 2xD ASR _____ 64



EXN1-M02 SLOTMAKER

EXN1-M02-0023 | EXN1 Slotmaker Z3 2xD ASR _____ 66

EXN1-M02-0024 | EXN1 Slotmaker Z3 2xD ASR _____ 68

EXN1-M02-0053 | EXN1 Slotmaker Z3 3xD ASR _____ 70

EXN1-M02-0054 | EXN1 Slotmaker Z3 3xD ASR _____ 72

EXN1-M02-0123 | EXN1 Slotmaker Z3 2xD IC ASR _____ 74

EXN1-M02-0124 | EXN1 Slotmaker Z3 2xD IC ASR _____ 76

EXN1-M02-0163 | EXN1 Slotmaker Z3 3xD IC ASR _____ 78

EXN1-M02-0164 | EXN1 Slotmaker Z3 3xD IC ASR _____ 80



EXN1-M03 CHIPMAKER

EXN1-M03-0033 | EXN1 Chipmaker Z4 3xD ASR _____ 82

EXN1-M03-0034 | EXN1 Chipmaker Z4 3xD ASR _____ 84

EXN1-M03-0043 | EXN1 Chipmaker Z4 4xD ASR _____ 86

EXN1-M03-0044 | EXN1 Chipmaker Z4 4xD ASR _____ 88



EXN1-M03-0053 | EXN1 Chipmaker Z4 5xD ASR _____ 90

EXN1-M03-0054 | EXN1 Chipmaker Z4 5xD ASR _____ 92

EXN1-M03-0133 | EXN1 Chipmaker Z4 3.5xD IC ASR _____ 94

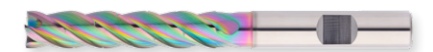
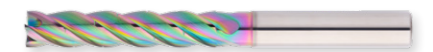

EXN1-M04 MIRRORMAKER

EXN1-M04-0033 | EXN1 Mirrormaker Z6 3xD ASR _____ 96

EXN1-M04-0043 | EXN1 Mirrormaker Z6 4xD ASR _____ 98

EXN1-M04-0053 | EXN1 Mirrormaker Z6 5xD ASR _____ 100

EXN1-M04-0133 | Mirrormaker Z5 3.5xD IC ASR _____ 102



EXN1-M05 BALANCEMAKER

EXN1-M05-0023 | EXN1 Balancemaker Z1 ASR _____ 104

EXN1-M05-0053 | EXN1 Balancemaker Z1 long ASR _____ 106



EXN1-M06 FORMMAKER

EXN1-M06-0003 | EXN1 Formmaker Z3 2xD ASR _____ 108

EXN1-M06-0013 | EXN1 Formmaker Z3 1.5xD long ASR _____ 112



EXN1-M08 ROWMAKER

EXN1-M08-0003 | EXN1 Rowmaker Z2 1.5xD short ASR _____ 116

EXN1-M08-0013 | EXN1 Rowmaker Z2 1.5xD long ASR _____ 118

EXN1-M08-0103 | EXN1 Rowmaker Z4 2xD short ASR _____ 120

EXN1-M08-0113 | EXN1 Rowmaker Z4 2xD long ASR _____ 122

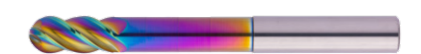

| EXN1-M15 PERFORMMAKER MICRO

EXN1-M15-0003 | EXN1 Performmaker Micro Z2 ASR _____ 124



| EXN1-M16 FORMMAKER MICRO

EXN1-M16-0023 | EXN1 Formmaker Micro Z2 R0.05 ASR _____ 130



EXN1-M16-0063 | EXN1 Formmaker Micro Z2 R0.1 ASR _____ 134



EXN1-M16-0103 | EXN1 Formmaker Micro Z2 R0.2 ASR _____ 140



EXN1-M16-0143 | EXN1 Formmaker Micro Z2 R0.3 ASR _____ 146



EXN1-M16-0183 | EXN1 Formmaker Micro Z2 R0.5 ASR _____ 150



| EXN1-M17 ROWMAKER MICRO

EXN1-M17-0003 | EXN1 Rowmaker Micro Z2 ASR _____ 154



EXN1-M17-0013 | EXN1 Rowmaker Micro long Z2 ASR _____ 158



EXPLANATION _____ 162

MATERIAL OVERVIEW _____ 164

TECHNICAL FORMULAS _____ 167

GENERAL TERMS OF SALE _____ 168

DISCOVER OUR H&V PRODUCT RANGE _____ 173



OUR EXN1 SERIES

Experts in cutting non-ferrous materials

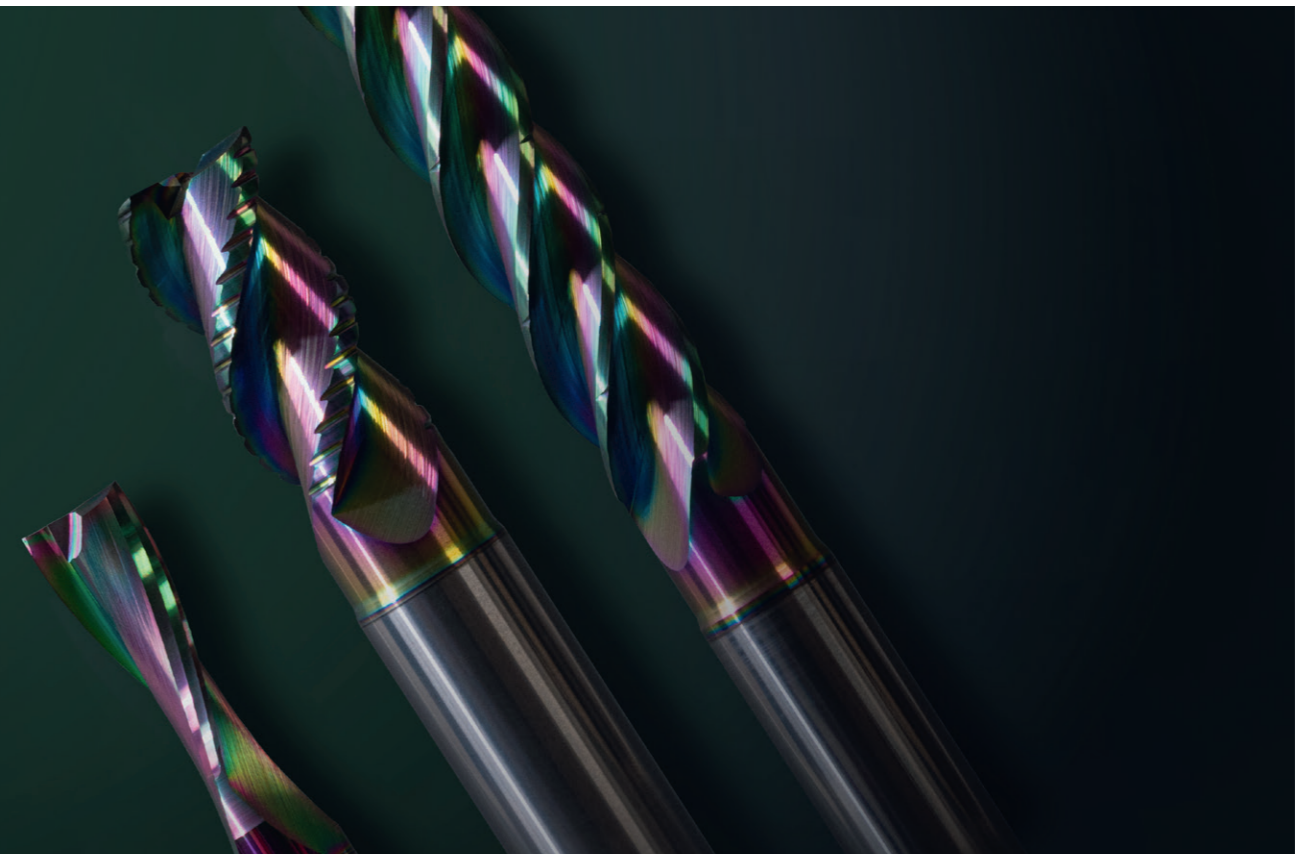

OUR EXN1 SERIES IS RENOWNED FOR ITS PARTICULARLY IMPRESSIVE PERFORMANCE WHEN MACHINING ALUMINIUM

Non-ferrous materials are very versatile and range from aluminium to plastic to multi-layered materials. In spite of their easy machinability, they make extra demands on the cutting tools due to their use as a composite material or their tendency to adhesion.

The H&V Expert EXN1 Series was developed to enable potentially easily machinable materials to be safely processed and to meet the specific requirements of non-ferrous material cutting.

- Fine-grain substrate, particularly suited to non-ferrous materials, for long-term retention of sharp edges and homogeneous wear
- Polished chip spaces for straightforward evacuation of chips
- High-performance geometry tailored to volume machining and surface quality

A SPECIAL EDGE PREPARATION PROCESS ENSURES:

- Entirely homogeneous cutting edges
- Even distribution of cutting forces
- Improved surface quality of the component
- Controlled and even wear



EXPERIENCE OUR EXN1 SERIES IN ACTION

BEFORE EDGE PREPARATION

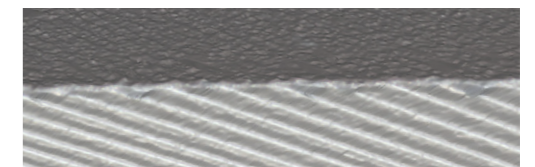

AFTER EDGE PREPARATION

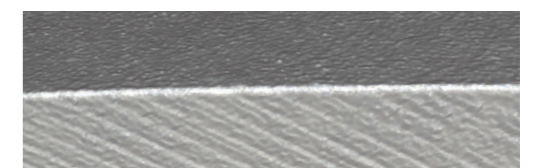

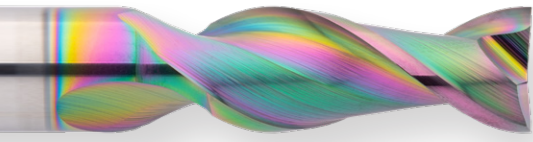

EXPERT N1 PERFORMMAKER (M01) Z2



► IN ACTION

- Defined clearance angle for improved stability with high cutting depths
- Special helical pitch for smooth running and cutting
- Expanded chip chambers for extremely high chip volumes
- Developed for use in the high-speed range
- Available as 2xD
- With ASR coating

Customized face
for reliable ramping
and helical immersion

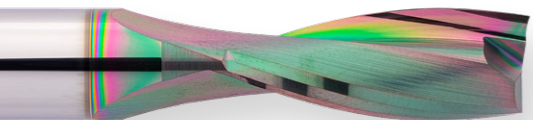
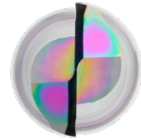

EXPERT N1 PERFORMMAKER (M01) Z2-3

- Extra sharp cutting edges for smooth and even cutting in all types of plastic
- Highly polished chip spaces for optimized chip evacuation
- Special helical pitch for smooth running
- Now with improved ASR coating

Optimized face
for helical immersion
in all types of plastic



EXPERT N1 PERFORMMAKER (M01) Z3



► IN ACTION

- Defined clearance angle for improved stability with high cutting depths
- Special helical pitch for smooth running and cutting
- Expanded chip chambers for extremely high chip volumes
- Available in normal and long versions, as well as 3xD
- With ASR coating

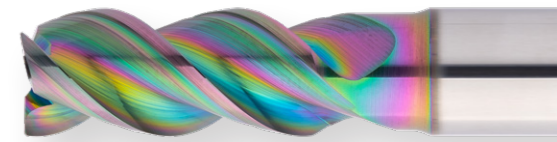

Customized face
for reliable ramping and
helical immersion

Available with and without
central internal cooling



EXPERT N1 PERFORMMAKER (M01) Z4



► IN ACTION

- Extra large chip chambers for optimum chip disposal, even with full slots and high radial depth of cutting
- Variable helical pitch for smooth running
- Special unequal tooth pitch for smooth cutting
- With ASR coating

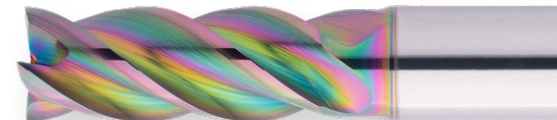

Reinforced face
with two cutting edges
cutting to the center,
for reliable ramping and
helical immersion

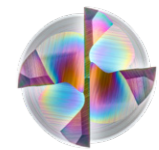

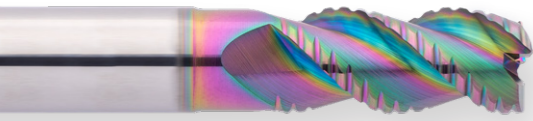

EXPERT N1 SLOTMAKER (M02) Z3



► IN ACTION

- Roughing teeth for the smallest chips in volume machining
- Special helical pitch for smooth running and cutting
- Expanded chip chambers for extremely high chip volumes
- Available in 2xD and 3xD
- With ASR coating

Customized face
for reliable ramping and
helical immersion

Available with and without
central internal cooling

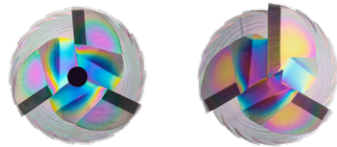

EXPERT N1 CHIPMAKER (M03) Z4



► IN ACTION

- Chip breaker for predefined chip length and preventing chip accumulations
- Customized chip chambers for optimum chip evacuation, even with high radial depth of cutting
- Variable helical pitch for smooth running
- Special unequal tooth pitch for smooth cutting
- Available in 3xD, 4xD and 5xD
- Available as HA and HB
- With ASR coating

Reinforced face
with two cutting edges
cutting to the center,
for reliable ramping and
helical immersion

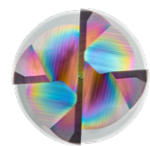

EXPERT N1 CHIPMAKER (M03) Z4

- Special aerospace design optimised for vibration-free milling and ideal chip removal for thin-walled components and complex internal machining operations
- Adapted chip breakers for defined chip length and maximum tool life
- Variable helical pitch combined with special unequal tooth pitch for smooth running and a soft cut
- With ASR coating

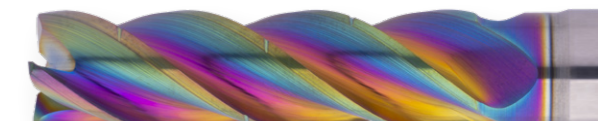

EXPERT N1 MIRRORMAKER (M04) Z6



► IN ACTION

- Six ultra-sharp and lapped cutting edges ensure excellent surface finishes and perfect dimensional accuracy
- Special chip chambers designed for the evacuation of particularly long and fine chips
- Variable helical pitch for smooth running
- Special unequal tooth pitch for smooth cutting
- Available in 3xD, 4xD and 5xD
- ASR coating approved for use in the food industry

Reinforced face with two
cutting edges to the center,
for reliable ramping and
helical immersion

With central internal cooling
and large corner radius

Radius tolerance is
determined by the
corner radius
≤ 1,5mm = ± 0,003mm
> 1,5mm = ± 0,005mm

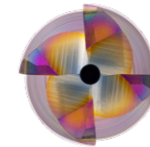

Face-finish-bevel
for smooth workpiece
surfaces

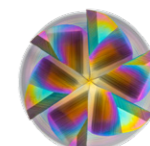

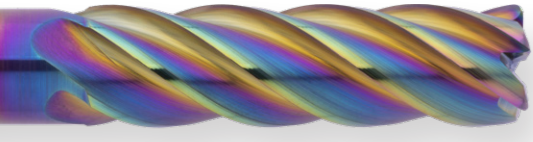

Face-finish bevel for smooth workpiece surfaces

With central internal cooling and large corner radius

Radius tolerance is determined by the corner radius
 $\leq 1,5 \text{ mm} = \pm 0,003 \text{ mm}$
 $> 1,5 \text{ mm} = \pm 0,005 \text{ mm}$

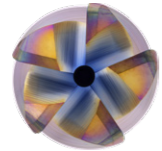

EXPERT N1 MIRRORMAKER (M04) Z5



► IN ACTION

- Special aerospace design optimised for vibration-free milling and ideal chip removal for thin-walled components and complex internal machining operations
- Five ultra-sharp and lapped cutting edges ensure excellent surfaces and highest shape accuracy
- Special chip chambers designed for the removal of very long and fine chips
- With ASR coating



Customized face for reliable ramping and helical immersion

Corner radii up to R=4.0 available for contour milling

Radius tolerance is determined by the corner radius
 $\leq 1.5 \text{ mm} = \pm 0.003 \text{ mm}$
 $> 1.5 \text{ mm} = \pm 0.005 \text{ mm}$

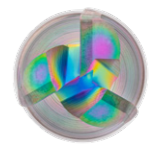

EXPERT N1 FORMMAKER (M06) Z3



► IN ACTION

- Defined clearance angle for improved stability with high cutting depths
- Special helical pitch for smooth running and cutting
- Expanded chip chambers for extremely high chip volumes
- Available in normal and long versions
- With ASR coating

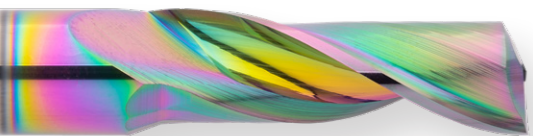

Customized face for reliable grooving and milling

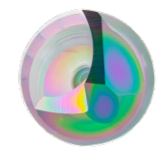

EXPERT N1 BALANCEMAKER (M05) Z1



► IN ACTION

- Defined clearance angle for improved stability with high cutting depths
- Optimized cutting geometry for smooth running and minimal imbalance
- Developed for use in the high-speed range
- Expanded chip chambers for extremely high chip volumes
- Available in normal and long versions
- With ASR coating

EXPERT N1 ROWMAKER (M08) Z2



► IN ACTION

- Developed for use in the high-speed range
- Defined microbevel for support and stabilisation
- Special chip chambers designed for optimal chip evacuation when roughing and finishing
- Available in normal and long versions
- With ASR coating

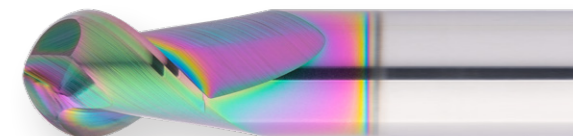

Optimized face design for excellent surface finishes and perfect dimensional accuracy when multipass milling

Radius tolerance is determined by the radius
 $\leq 2 \text{ mm} = \pm 0.003 \text{ mm}$
 $> 2 \text{ mm} = \pm 0.005 \text{ mm}$



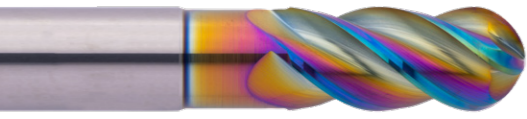

Optimized face design for excellent surface finishes and perfect dimensional accuracy when multipass milling

Radius tolerance is determined by the radius
 $\leq 2 \text{ mm} = \pm 0.003 \text{ mm}$
 $> 2 \text{ mm} = \pm 0.005 \text{ mm}$

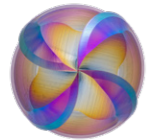

EXPERT N1 ROWMAKER (M08) Z4



► IN ACTION

- Developed for use in the high-speed range
- Four cutting edges with defined microbevel for best dimensional accuracy at high rates of removal
- Optimized chip chambers designed for optimal chip evacuation when roughing and finishing
- Available in normal and long versions
- With ASR coating

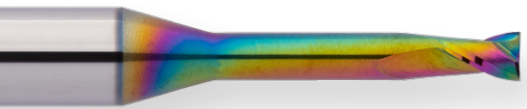

Optimized face design for excellent surface finishes and perfect dimensional accuracy

Available with cutting edges
 $\varnothing 0.2 - 2.5 \text{ mm}$

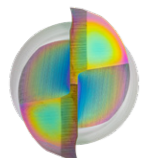

EXPERT N1 PERFORMMAKER MICRO (M15) Z2

- Defined microbevel for support and stabilisation
- Customized core for smooth running
- Polished chip spaces for optimum chip evacuation
- Now with improved ASR coating
- The tightest tolerances for high-precision manufacturing
 - Clearance diameter: $0/-0.02 \text{ mm}$
 - Cutting diameter: $-0.001/-0.006 \text{ mm}$

EXPERT N1 FORMMAKER MICRO (M16) Z2

- Defined microbevel for support and stabilisation
- Customized core for smooth running
- Polished chip spaces for optimum chip evacuation
- Now with improved ASR coating
- The tightest tolerances for high-precision manufacturing
 - Clearance diameter: $0/-0.02 \text{ mm}$
 - Cutting diameter: $-0.001/-0.006 \text{ mm}$



Optimized face design for excellent surface finishes and perfect dimensional accuracy when multipass milling

Available with cutting edges
 $\varnothing 0.2 - 3 \text{ mm}$

Available with $R=0.05 \text{ mm}$ to
 $R=0.5 \text{ mm}$

Radius tolerance $0/-0.003 \text{ mm}$
 (measured from $0 - 90^\circ$)

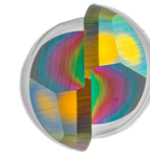

EXPERT N1 ROWMAKER MICRO (M17) Z2



► IN ACTION

- Defined microbevel for support and stabilisation
- Customized core for smooth running
- Polished chip spaces for optimum chip evacuation
- Now with improved ASR coating
- Available in normal and long versions
- The tightest tolerances for high-precision manufacturing
 - Clearance diameter: $0/-0.02 \text{ mm}$
 - Cutting diameter: $-0.001/-0.006 \text{ mm}$



Optimized face design for excellent surface finishes and perfect dimensional accuracy when multipass milling

Available with cutting edges
 $\varnothing 0.1 - 3 \text{ mm}$

Radius tolerance $0/-0.003 \text{ mm}$
 (measured from $0 - 90^\circ$)

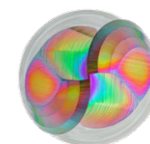

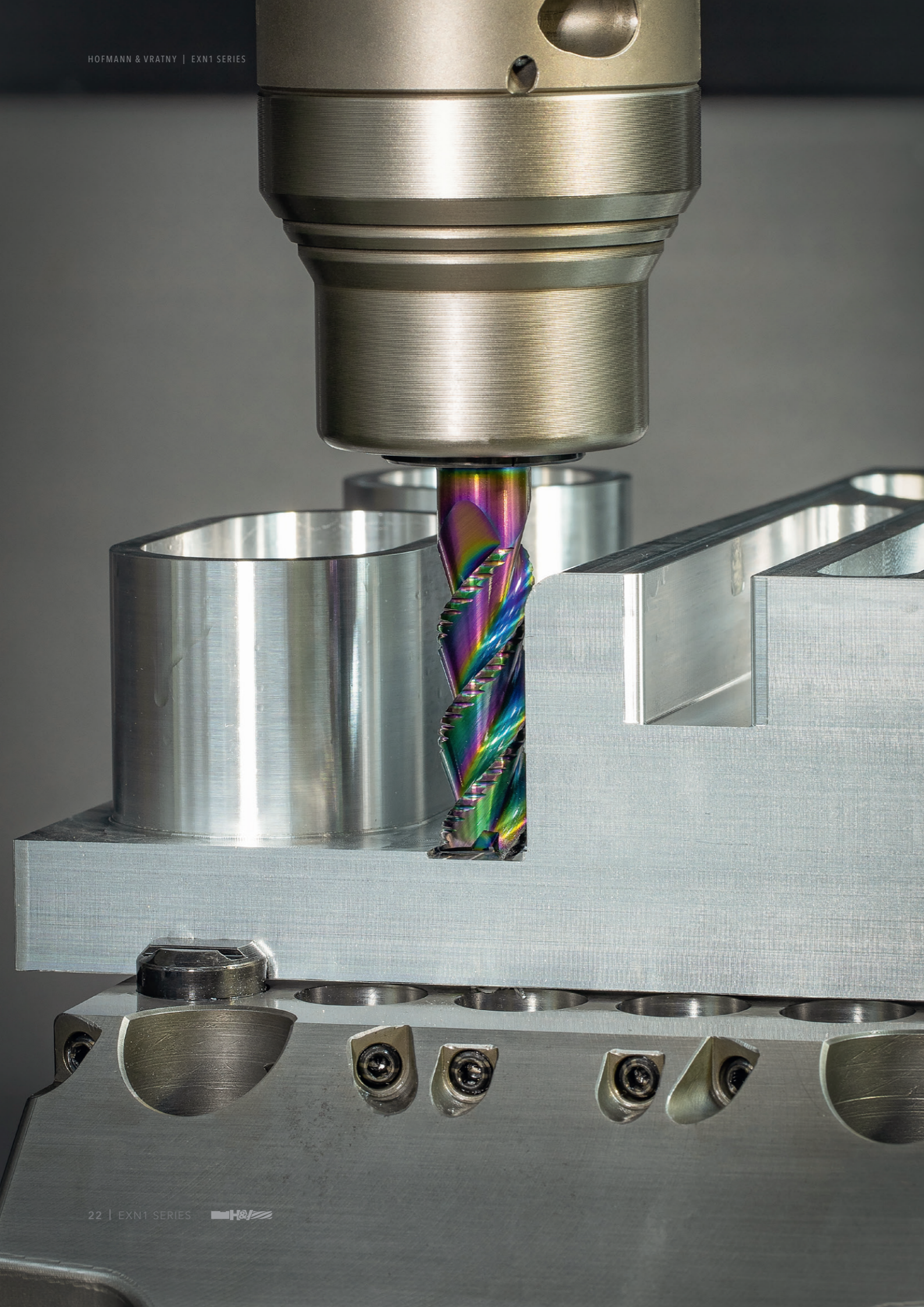

APPLICATION EXAMPLES

THE EXN1 SERIES IN OPERATION

Manufacture of high-precision rails made of AlMg3 with 240 N/mm².
 To date, the customer has been using standard aluminium milling cutters with a ZrN coating. By switching to the H&V EXN1 Series (PERFORMMAKER & MIRRORMAKER), the production time per component was able to be reduced by more than 50%. Thanks to higher cutting depths and higher feed rates, the surface quality was also improved to a roughness (Ra) of less than 1 µm.

EXAMPLES OF MACHINING PARAMETERS WHEN ROUGHING WITH A FULL-SLOT
 3-CUTTING EDGE END MILL CUTTER, Ø 12, 2XD

	Ae	Ap	Fz (mm/Z)	Vc (m/min)
EXN1 Performmaker Z3 2XD ASR	1xD	1.5xD	0.25	480
ZrN Z3 competitor	1xD	1.5xD	0.1	480
TAC Z3 competitor	1xD	1.5xD	0.12	480

Tool matrix for the EXN1-Series

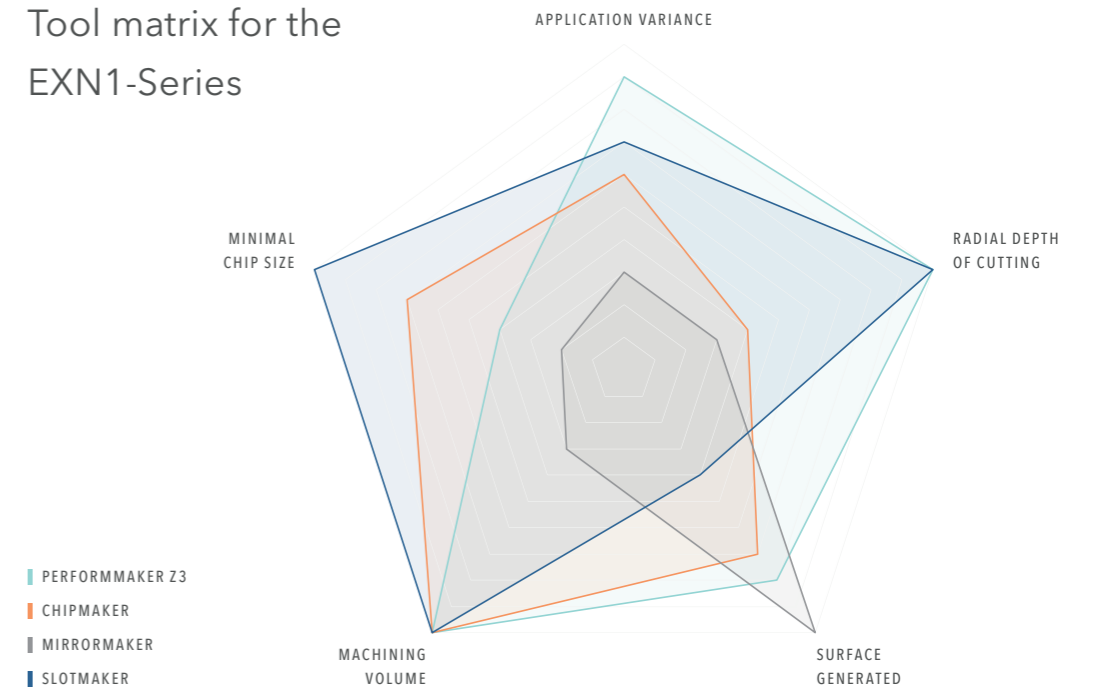

ALPHA SLIDE RAINBOW

NEW ASR | Innovative coating - Our new coating made of tetragonal carbon

Traditional TAC coatings are usually characterized by their high degree of hardness, very good wear resistance and stable slide characteristics. Our previous TAC Alpha coating met all of these criteria.

Now, our new AlphaSlide Rainbow (ASR) takes TAC coatings to the next level. Thanks to a new coating process that completely dispenses with hydrogen, among other things, we were able to:

- Increase sp3 bonds to over 85 %
- Reduce the coating thickness to less than 1 µm
- Reduce the coating hardness to approx. 4500 HV

STRUCTURE OF THE ALPHASLIDE RAINBOW (ASR)

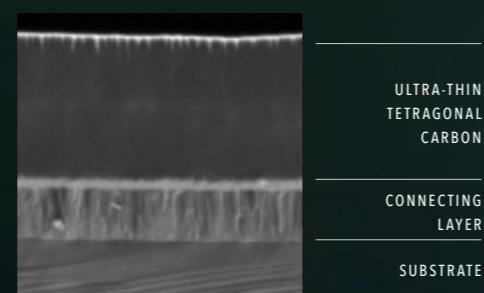

ULTRA-THIN
TETRAGONAL
CARBON

CONNECTING
LAYER

SUBSTRATE

ASR Improvements to the traditional TAC coating (TAC Alpha)

- Increased tool life when roughing with full slots, trimming and multipass milling
- Better surface quality of the workpiece in finishing, trimming and multipass milling
- Increased smoothness (virtually free from droplets) and thus reduced friction coefficient. Ensures optimum chip evacuation, even in unpolished chip spaces
- Perfect retention of the sharp cutting edges thanks to the natural geometry and defined edge preparation
- High stability of the coating and cutting edges, even in unstable machining situations (e.g. vibrations)
- Prevention of built-up edges, even in unfavourable application scenarios involving adhesive alloys

ALPHASLIDE RAINBOW ASR AT A GLANCE

Structure	Completely hydrogen-free
Layer thickness	< 1 µm
Sp3 bonds	> 85%
Layer hardness	approx. 4500 HV
Biocompatibility	100%*
Friction coefficient	Friction coefficient: approx. 0.05 (dry on steel)
Max. operating temperature	approx. 420–450 °C, dry and wet
Main application	Aluminium (wrought alloys and cast alloys), plastic, copper
Secondary application (limited suitability)	CFRP/GFRP, graphite, Ti alloys and wood

* Biocompatibility must be checked independently by the customer for the respective application

OUR EXN1 SERIES

DETAILED COATING COMPARISON

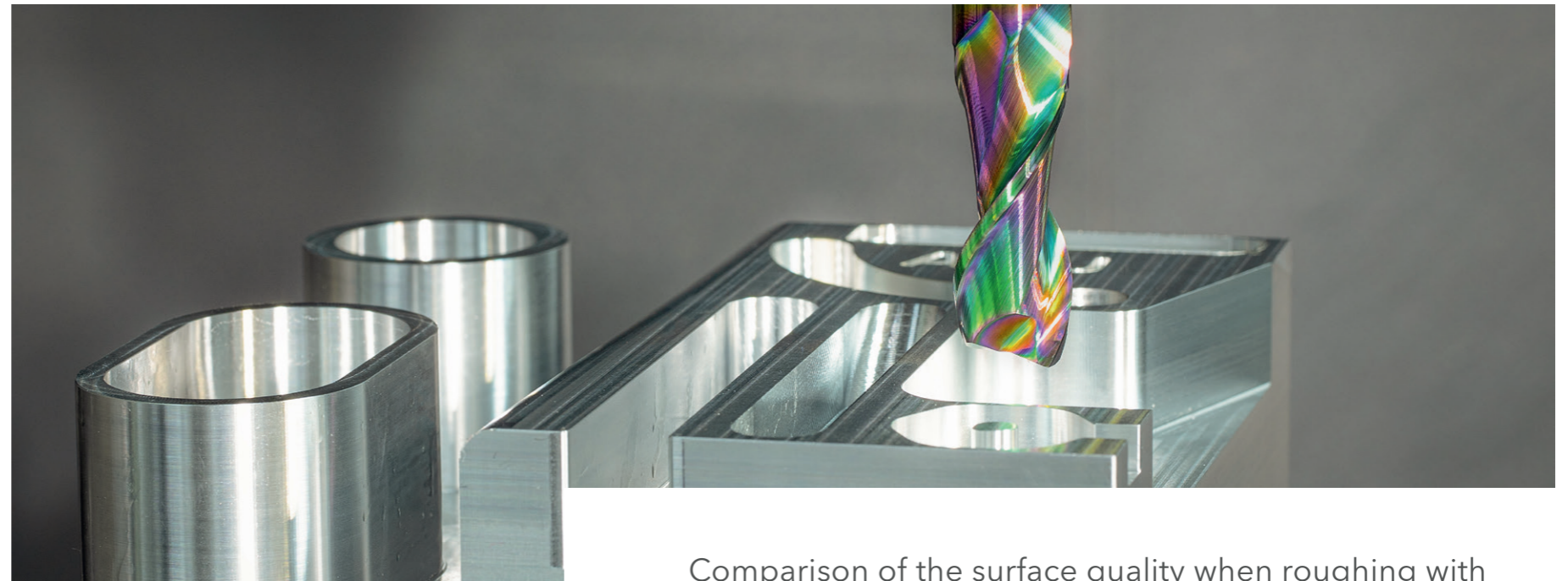

Comparison of the tool life when roughing in AlMg3

In addition, our new AlphaSlide Rainbow coating successfully prevailed over our previous TAC Alpha coating and the coatings of competitors in the comprehensive field test with regard to tool life.

TOOL LIFE CRITERION = BUILT-UP EDGE AND BREAKOUTS

EXN1-M01-0103-16 (3-cutting edge end mill cutter, Ø 16, 2xD)	Number of components
AlphaSlide Rainbow	1500
TAC Alpha (previous coating)	1150
TAC competitor	1200
ZrN competitor	1050

Comparison of the surface quality when roughing with a subsequent finishing process in AlMg3

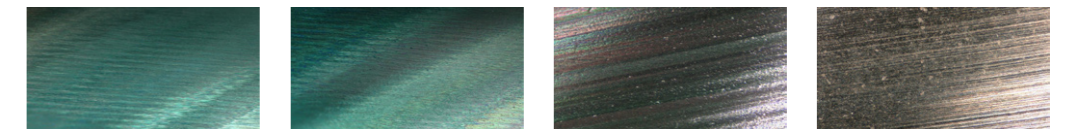

Measured value*	AlphaSlide Rainbow (ASR)	TAC Alpha (previous coating)	TAC competitor	ZrN competitor
Straightness	0.0012 mm	0.0026 mm	0.0097 mm	0.0092 mm
Roughness (Ra)	0.810 µm	1.06 µm	1.821 µm	2.133 µm

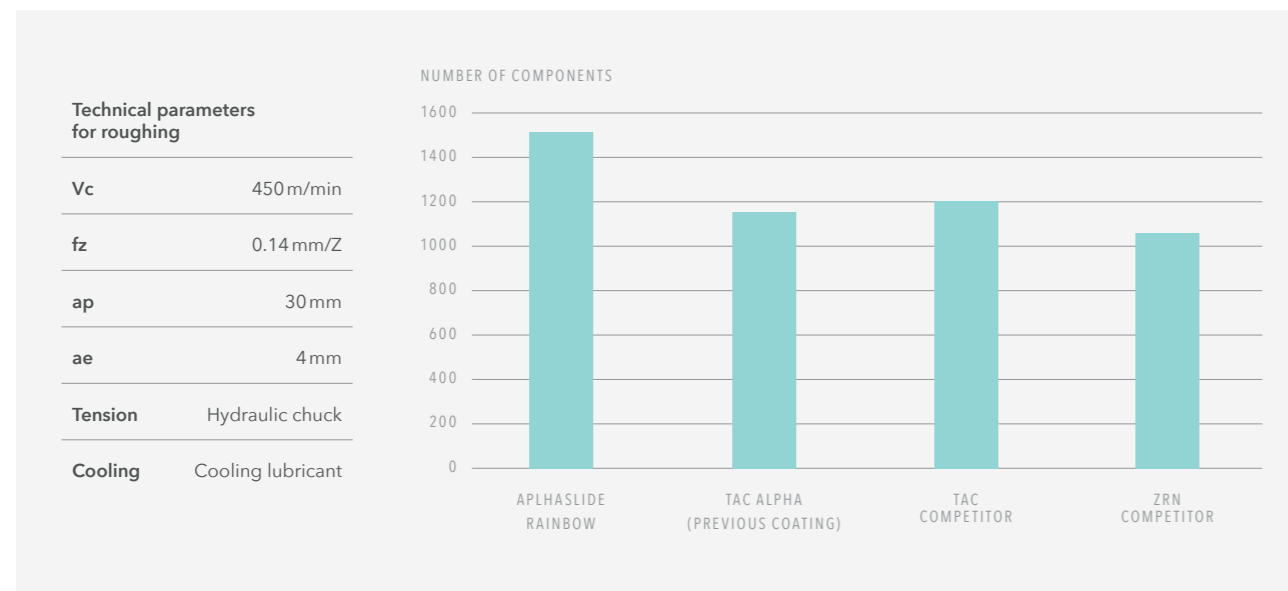

Technical parameters for roughing		Technical parameters for finishing	
Vc	450 m/min	Vc	450 m/min
fz	0.14 mm/Z	fz	0.05 mm/Z
ap	30 mm	ap	30 mm
ae	4 mm	ae	0.2 mm
Tension	Hydraulic chuck	Tension	Hydraulic chuck
Cooling	Cooling lubricant		

*Determined using a measuring sensor on the machined workpiece

DIGITAL SERVICES



DISTRIBUTION PARTNERS

We enable companies around the world to manufacture their products. Therefore we work with reliable partners at an international level to ensure that our milling cutters are always available exactly where they are needed and can be delivered straight into your hands.

FIND OUT MORE ABOUT OUR GLOBAL SALES PARTNERS



Browse all EXN1 Series products in our shop

Discover the products in the EXN1 Series online or search for the ideal tool for your application based on various product features. We guarantee, that you will find the perfect milling cutter for your machining needs using our online platform.



WHAT ARE YOU WAITING FOR?

STILL CAN'T FIND A SUITABLE MILLING CUTTER?

No problem - simply customize an existing tool. Using our configurator for special milling cutters, you can customize existing tools to your needs in an instant or create your own tools based on predefined types.

WE WILL RESPOND TO ALL REQUESTS SUBMITTED VIA THE CONFIGURATOR WITHIN ONE WORKING DAY AT THE LATEST



NUMBERING SYSTEM

DISTINGUISHING FEATURES

PRODUCT LINE BC Basic EX Expert	TOOL TYPE D Drilling M Milling	MILLING CUTTER TYPE 01 End mill cutter PERFORMMAKER 02 Roughing cutter SLOTMAKER 03 Trochoidal cutter CHIPMAKER 04 Finishing cutter MIRRORMAKER 05 Single flute cutter BALANCEMAKER 06 Torus cutter FORMMAKER 07 Face torus cutter BLADEMAKER 08 Full radius cutter ROWMAKER 09 Deburring cutter CHAMFMAKER 10 Forward and backward deburring cutter FB CHAMFMAKER 11 Corner rounding cutter ROUNDMAKER 12 Forward and backward corner rounding cutter FB ROUNDMAKER 13 Engraving cutter TEXTMAKER 14 Conical cutter SLOPEMAKER 15 Micro end mill cutter PERFORMMAKER MICRO 16 Micro torus cutter FORMMAKER MICRO 17 Micro full radius cutter ROWMAKER MICRO
--	---	--

EX N 1 - M 01 - 0293

MAIN APPLICATION PK Steel & Cast Iron H Hardened Steel M Stainless Steel O Graphite, CRP/GRP T Titanium S Superalloy N NF Material U Universal	VERSION 0 Origin Version 1 Version 1.0 2 Version 2.0 3 Version 3.0
---	---

OTHER DISTINGUISHING FEATURES

EX N 1 - M 01 - 0293 - 12/0,5

PRODUCT IDENT e.g. 0023	DIMENSION 3x10 Cutting diameter x length of undercut 12/0,5 Cutting diameter / corner radius 10 Diameter
-----------------------------------	--

Cooling	
Tolerance	e8
Coating	AlphaSlide Rainbow

Strategy	ETC	HPC	
Application			
Features	HA		

- Extra sharp cutting edges for a smooth and soft cut in all plastics
- Highly polished chip space for optimized chip evacuation
- Special helical pitch for smooth running

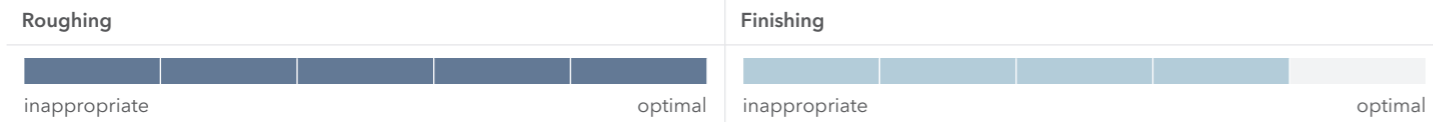
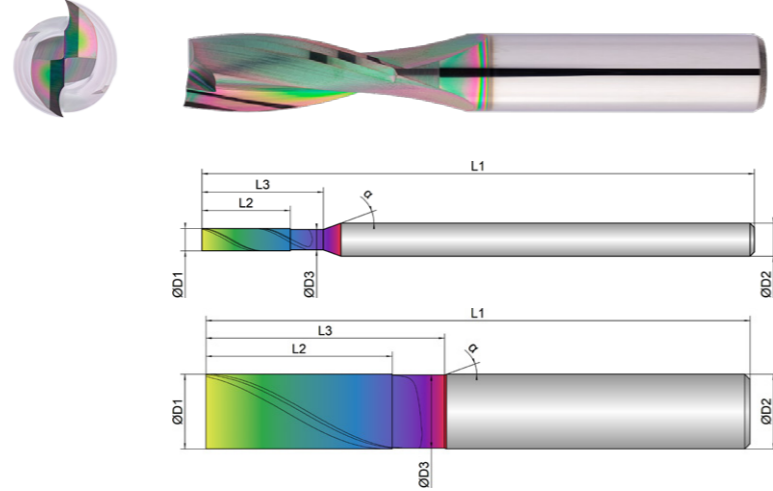

EXN1-M01-0013	D1	D3	L2	L3	L1	D2	z		α
	mm \varnothing	mm \varnothing	mm	mm	mm	mm \varnothing	#		
1	1.0	0.9	5.0	8.0	50.0	3.0	2	20	20
2	2.0	1.85	8.0	11.0	50.0	3.0	2	20	20
3	3.0	2.8	11.0	14.0	50.0	3.0	2	20	20
4	4.0	3.8	13.0	16.0	54.0	4.0	2	20	20
5	5.0	4.8	15.0	18.0	54.0	5.0	2	20	20
6	6.0	5.8	16.0	21.0	65.0	6.0	2	20	20
8	8.0	7.8	22.0	27.0	70.0	8.0	2	20	20
10	10.0	9.8	25.0	32.0	73.0	10.0	2	20	20
12	12.0	11.8	28.0	38.0	84.0	12.0	3	20	20
14	14.0	13.8	30.0	42.0	84.0	14.0	3	20	20
16	16.0	15.8	36.0	44.0	93.0	16.0	3	20	20
20	20.0	19.8	41.0	54.0	104.0	20.0	3	20	20



Download Catalog Pages (PDF)

Dimension	Ø1		Ø2		Ø3		Ø4		Ø5		Ø6	
Infeed in mm	ae=1xD	ae=0.4xD	ae=1xD	ae=0.4xD	ae=1xD	ae=0.4xD	ae=1xD	ae=0.4xD	ae=1xD	ae=0.4xD	ae=1xD	ae=0.4xD
Application												

Material	Strength (N/mm ²)	Feed (mm/Z)	fz	fz	fz	fz	fz	fz	fz	fz	fz	fz	fz		
NON-FERROUS		Vc (m/min)													
1.1	ALUMINIUM alloyed	<500													
1.2	ALUMINIUM alloyed	<600													
2.1-2.3	ALUMINIUM casted	<600													
3.1-3.3	COPPER alloyed	<650													
4.1	MAGNESIUM alloyed	<250													
5.1	PLASTICS Thermoplastic	<100	480	0.004	0.007	0.006	0.01	0.008	0.012	0.012	0.02	0.015	0.025	0.025	0.04
5.2	PLASTICS Duroplastic	<150	420	0.003	0.006	0.005	0.009	0.006	0.01	0.01	0.016	0.01	0.02	0.02	0.035

Dimension	Ø8		Ø10		Ø12		Ø14		Ø16		Ø20	
Infeed in mm	ae=1xD	ae=0.4xD	ae=1xD	ae=0.4xD	ae=1xD	ae=0.4xD	ae=1xD	ae=0.4xD	ae=1xD	ae=0.4xD	ae=1xD	ae=0.4xD
Application												

Material	Strength (N/mm ²)	Feed (mm/Z)	fz	fz	fz	fz	fz	fz	fz	fz	fz	fz	fz		
NON-FERROUS		Vc (m/min)													
1.1	ALUMINIUM alloyed	<500													
1.2	ALUMINIUM alloyed	<600													
2.1-2.3	ALUMINIUM casted	<600													
3.1-3.3	COPPER alloyed	<650													
4.1	MAGNESIUM alloyed	<250													
5.1	PLASTICS Thermoplastic	<100	480	0.03	0.05	0.04	0.055	0.048	0.075	0.05	0.085	0.055	0.09	0.06	0.11
5.2	PLASTICS Duroplastic	<150	420	0.025	0.045	0.035	0.05	0.044	0.065	0.04	0.075	0.045	0.08	0.05	0.1

Cooling	
Tolerance	h6
Coating	AlphaSlide Rainbow

Strategy	ETC	HSC	HPC	
Application				
Features	HA	2xD		

- Defined clearance angle for ideal stabilization with high cutting depths
 - Special helical pitch for smooth running and soft cut
 - Extra large chip chambers for an extreme chip volume
- For roughing and finishing, up to 1.5xD full slot
 - For process reliable, helical diving and immersion
- For use in high speed milling machines

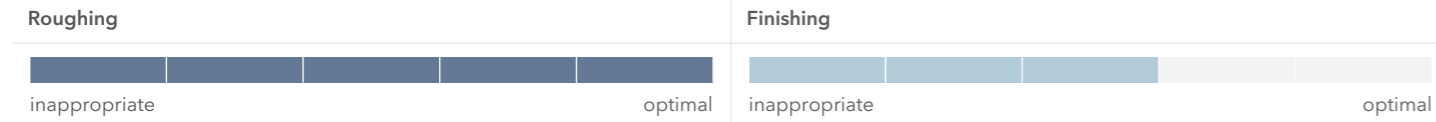
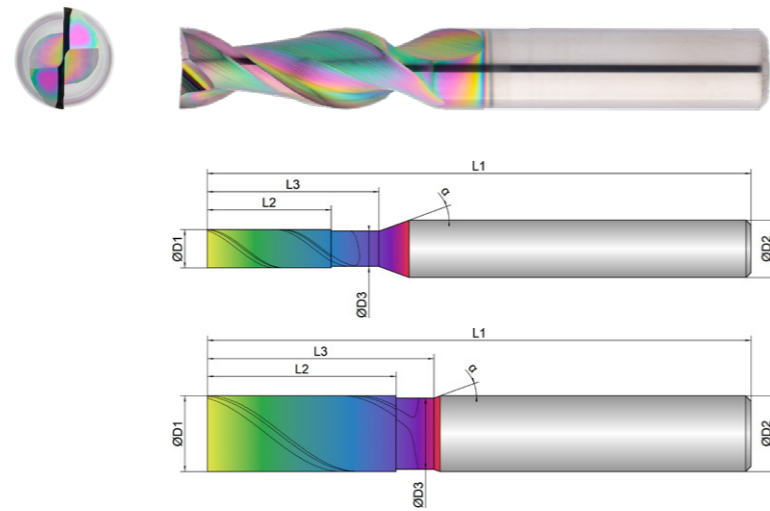

EXN1-M01-0043	D1	D3	L2	L3	L1	D2	z		α
	mm \varnothing	mm \varnothing	mm	mm	mm	mm \varnothing	#		
1	1.0	0.9	3.0	5.0	57.0	6.0	2	38	20
2	2.0	1.8	6.0	8.0	57.0	6.0	2	38	20
3	3.0	2.8	8.0	13.0	57.0	6.0	2	38	20
4	4.0	3.7	13.0	18.0	57.0	6.0	2	38	20
6	6.0	5.5	16.0	21.0	57.0	6.0	2	38	20
8	8.0	7.5	22.0	27.0	63.0	8.0	2	38	20
10	10.0	9.4	25.0	30.0	72.0	10.0	2	38	20
12	12.0	11.4	28.0	33.0	83.0	12.0	2	38	20
16	16.0	15.4	36.0	41.0	92.0	16.0	2	38	20
20	20.0	19.4	41.0	51.0	104.0	20.0	2	38	20



Download Catalog Pages (PDF)

Dimension	Ø1		Ø2		Ø3		Ø4		Ø6		Ø8	
Infeed in mm	ae=1xD	ae=0.3xD	ae=1xD	ae=0.3xD	ae=1xD	ae=0.3xD	ae=1xD	ae=0.3xD	ae=1xD	ae=0.3xD	ae=1xD	ae=0.3xD
Application												

N	Material	Strength (N/mm ²)	Feed (mm/Z)	Vc (m/min)											
				fz	fz	fz	fz	fz	fz	fz	fz	fz	fz	fz	fz
1.1	ALUMINIUM alloyed	<500	500	0.018	0.025	0.025	0.035	0.035	0.05	0.05	0.06	0.06	0.08	0.08	0.09
1.2	ALUMINIUM alloyed	<600	480	0.018	0.025	0.025	0.035	0.035	0.05	0.05	0.06	0.06	0.08	0.08	0.09
2.1-2.3	ALUMINIUM casted	<600	450	0.015	0.02	0.02	0.03	0.03	0.045	0.045	0.055	0.055	0.075	0.07	0.08
3.1-3.3	COPPER alloyed	<650	200	0.012	0.015	0.015	0.025	0.025	0.04	0.04	0.05	0.05	0.07	0.06	0.07
4.1	MAGNESIUM alloyed	<250	500	0.018	0.025	0.025	0.035	0.035	0.05	0.05	0.06	0.06	0.08	0.08	0.09
5.1	PLASTICS Thermoplastic	<100	400	0.012	0.015	0.015	0.025	0.025	0.04	0.04	0.05	0.05	0.06	0.06	0.07
5.2	PLASTICS Duroplastic	<150	350	0.01	0.012	0.012	0.02	0.02	0.03	0.03	0.04	0.04	0.05	0.05	0.06

Dimension	Ø10		Ø12		Ø16		Ø20	
Infeed in mm	ae=1xD	ae=0.3xD	ae=1xD	ae=0.3xD	ae=1xD	ae=0.3xD	ae=1xD	ae=0.3xD
Application								

N	Material	Strength (N/mm ²)	Feed (mm/Z)	Vc (m/min)							
				fz	fz	fz	fz	fz	fz	fz	fz
1.1	ALUMINIUM alloyed	<500	500	0.09	0.12	0.1	0.14	0.14	0.18	0.18	0.22
1.2	ALUMINIUM alloyed	<600	480	0.09	0.12	0.1	0.14	0.14	0.18	0.18	0.22
2.1-2.3	ALUMINIUM casted	<600	450	0.08	0.11	0.09	0.13	0.12	0.16	0.16	0.2
3.1-3.3	COPPER alloyed	<650	200	0.07	0.1	0.09	0.13	0.12	0.16	0.16	0.2
4.1	MAGNESIUM alloyed	<250	500	0.09	0.12	0.1	0.14	0.14	0.18	0.18	0.22
5.1	PLASTICS Thermoplastic	<100	400	0.07	0.08	0.08	0.09	0.09	0.11	0.11	0.14
5.2	PLASTICS Duroplastic	<150	350	0.06	0.07	0.07	0.08	0.08	0.1	0.1	0.13

Cooling	
Tolerance	h6
Coating	AlphaSlide Rainbow

Strategy	ETC	HPC	
Application			
Features	HA	≠	

- Defined clearance angle for ideal stabilization with high cutting depths
 - Special helical pitch for smooth running and soft cut
 - Extra large chip chambers for an extreme chip volume
- For process reliable, helical diving and immersion
 - For roughing and finishing, up to 2xD full slot
- Sharp-edged version without edge protection

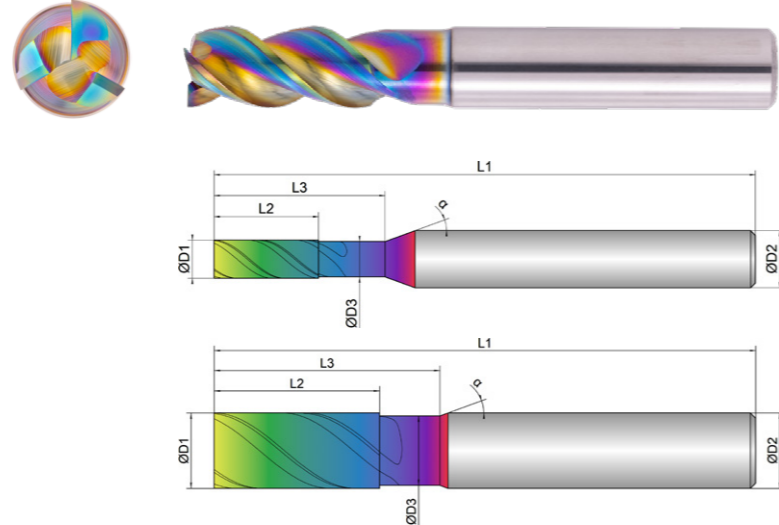

Roughing					Finishing				
inappropriate					optimal				

EXN1-M01-0093	D1	D3	L2	L3	L1	D2	z	α
	mm	mm	mm	mm	mm	mm	#	°
2	2.0	1.8	6.0	12.0	57.0	6.0	3	45
3	3.0	2.7	8.0	14.0	57.0	6.0	3	45
4	4.0	3.7	11.0	16.0	57.0	6.0	3	45
5	5.0	4.7	13.0	18.0	57.0	6.0	3	45
6	6.0	5.7	13.0	20.0	57.0	6.0	3	45
8	8.0	7.4	21.0	26.0	63.0	8.0	3	45
10	10.0	9.2	22.0	31.0	72.0	10.0	3	45
12	12.0	11.0	26.0	37.0	83.0	12.0	3	45
16	16.0	15.0	36.0	43.0	92.0	16.0	3	45
20	20.0	19.0	41.0	53.0	104.0	20.0	3	45



Download Catalog Pages (PDF)

Dimension	Ø2		Ø3		Ø4		Ø5		Ø6		Ø8	
Infeed in mm	ae=1xD	ae=0.3xD	ae=1xD	ae=0.3xD	ae=1xD	ae=0.3xD	ae=1xD	ae=0.3xD	ae=1xD	ae=0.3xD	ae=1xD	ae=0.3xD
Application												

N	Material	Strength (N/mm ²)	Feed (mm/Z)	fz	fz	fz	fz	fz	fz	fz	fz	fz	fz	fz	
NON-FERROUS				Vc (m/min)											
1.1	ALUMINIUM alloyed	<500	500	0.025	0.04	0.04	0.05	0.05	0.06	0.055	0.07	0.06	0.08	0.08	0.1
1.2	ALUMINIUM alloyed	<600	480	0.025	0.04	0.04	0.05	0.05	0.06	0.055	0.07	0.06	0.08	0.08	0.1
2.1-2.3	ALUMINIUM casted	<600	450	0.02	0.035	0.035	0.045	0.045	0.055	0.05	0.065	0.055	0.075	0.075	0.09
3.1-3.3	COPPER alloyed	<650	200	0.015	0.03	0.03	0.04	0.04	0.05	0.045	0.06	0.05	0.07	0.07	0.085
4.1	MAGNESIUM alloyed	<250	500	0.025	0.04	0.04	0.05	0.05	0.06	0.055	0.07	0.06	0.08	0.08	0.1
5.1	PLASTICS Thermoplastic	<100	400	0.015	0.03	0.03	0.04	0.04	0.045	0.04	0.05	0.045	0.065	0.055	0.065
5.2	PLASTICS Duroplastic	<150	350	0.012	0.025	0.025	0.035	0.03	0.035	0.035	0.04	0.035	0.055	0.045	0.055

Dimension	Ø10		Ø12		Ø16		Ø20	
Infeed in mm	ae=1xD	ae=0.3xD	ae=1xD	ae=0.3xD	ae=1xD	ae=0.3xD	ae=1xD	ae=0.3xD
Application								

N	Material	Strength (N/mm ²)	Feed (mm/Z)	fz	fz	fz	fz	fz	fz	fz	fz
NON-FERROUS				Vc (m/min)							
1.1	ALUMINIUM alloyed	<500	500	0.09	0.12	0.1	0.14	0.14	0.18	0.18	0.22
1.2	ALUMINIUM alloyed	<600	480	0.09	0.12	0.1	0.14	0.14	0.18	0.18	0.22
2.1-2.3	ALUMINIUM casted	<600	450	0.08	0.11	0.09	0.13	0.13	0.17	0.17	0.2
3.1-3.3	COPPER alloyed	<650	200	0.075	0.1	0.085	0.12	0.12	0.16	0.16	0.18
4.1	MAGNESIUM alloyed	<250	500	0.09	0.12	0.1	0.14	0.14	0.18	0.18	0.22
5.1	PLASTICS Thermoplastic	<100	400	0.065	0.085	0.075	0.11	0.11	0.13	0.13	0.17
5.2	PLASTICS Duroplastic	<150	350	0.055	0.075	0.065	0.1	0.1	0.12	0.12	0.16

Cooling	
Tolerance	h6
Coating	AlphaSlide Rainbow

Strategy	ETC HPC	
Application		
Features	HB ≠	

- Defined clearance angle for ideal stabilization with high cutting depths
 - Special helical pitch for smooth running and soft cut
 - Extra large chip chambers for an extreme chip volume
-
- For process reliable, helical diving and immersion
 - For roughing and finishing, up to 2xD full slot
-
- Sharp-edged version without edge protection

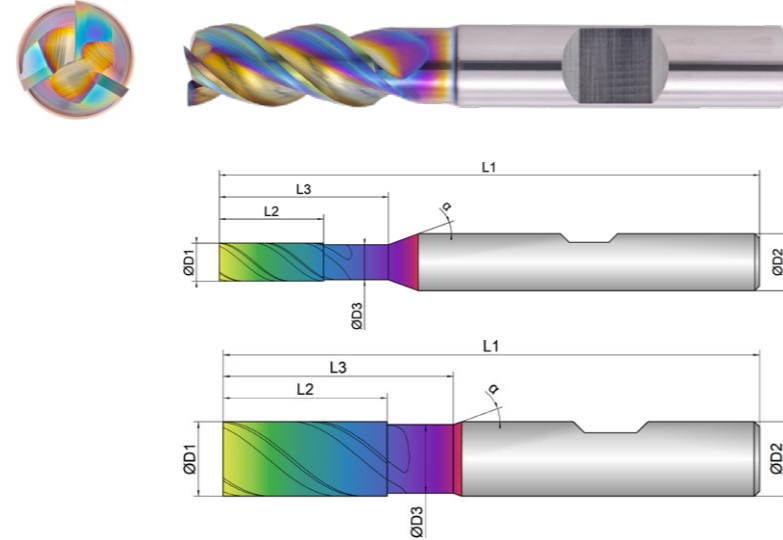

Roughing					Finishing				
inappropriate					optimal				

EXN1-M01-0094	D1	D3	L2	L3	L1	D2	z		α
	mm	mm	mm	mm	mm	mm	#	°	°
2	2.0	1.8	6.0	12.0	57.0	6.0	3	45	20
3	3.0	2.7	8.0	14.0	57.0	6.0	3	45	20
4	4.0	3.7	11.0	16.0	57.0	6.0	3	45	20
5	5.0	4.7	13.0	18.0	57.0	6.0	3	45	20
6	6.0	5.7	13.0	20.0	57.0	6.0	3	45	20
8	8.0	7.4	21.0	26.0	63.0	8.0	3	45	20
10	10.0	9.2	22.0	31.0	72.0	10.0	3	45	20
12	12.0	11.0	26.0	37.0	83.0	12.0	3	45	20
16	16.0	15.0	36.0	43.0	92.0	16.0	3	45	20
20	20.0	19.0	41.0	53.0	104.0	20.0	3	45	20



Download Catalog Pages (PDF)

Dimension	Ø2		Ø3		Ø4		Ø5		Ø6		Ø8	
Infeed in mm	ae=1xD	ae=0.3xD	ae=1xD	ae=0.3xD	ae=1xD	ae=0.3xD	ae=1xD	ae=0.3xD	ae=1xD	ae=0.3xD	ae=1xD	ae=0.3xD
Application												

Material	Strength (N/mm²)	Feed (mm/Z)	fz	fz	fz	fz	fz	fz	fz	fz	fz	fz	fz
N NON-FERROUS		Vc (m/min)											
1.1 ALUMINIUM alloyed	<500	500	0.025	0.04	0.04	0.05	0.05	0.06	0.055	0.07	0.06	0.08	0.08
1.2 ALUMINIUM alloyed	<600	480	0.025	0.04	0.04	0.05	0.05	0.06	0.055	0.07	0.06	0.08	0.08
2.1-2.3 ALUMINIUM casted	<600	450	0.02	0.035	0.035	0.045	0.045	0.055	0.05	0.065	0.055	0.075	0.075
3.1-3.3 COPPER alloyed	<650	200	0.015	0.03	0.03	0.04	0.04	0.05	0.045	0.06	0.05	0.07	0.07
4.1 MAGNESIUM alloyed	<250	500	0.025	0.04	0.04	0.05	0.05	0.06	0.055	0.07	0.06	0.08	0.08
5.1 PLASTICS Thermoplastic	<100	400	0.015	0.03	0.03	0.04	0.04	0.045	0.04	0.05	0.045	0.065	0.055
5.2 PLASTICS Duroplastic	<150	350	0.012	0.025	0.025	0.035	0.03	0.035	0.035	0.04	0.035	0.055	0.045

Dimension	Ø10		Ø12		Ø16		Ø20	
Infeed in mm	ae=1xD	ae=0.3xD	ae=1xD	ae=0.3xD	ae=1xD	ae=0.3xD	ae=1xD	ae=0.3xD
Application								

Material	Strength (N/mm²)	Feed (mm/Z)	fz	fz	fz	fz	fz	fz	fz
N NON-FERROUS		Vc (m/min)							
1.1 ALUMINIUM alloyed	<500	500	0.09	0.12	0.1	0.14	0.14	0.18	0.18
1.2 ALUMINIUM alloyed	<600	480	0.09	0.12	0.1	0.14	0.14	0.18	0.18
2.1-2.3 ALUMINIUM casted	<600	450	0.08	0.11	0.09	0.13	0.13	0.17	0.17
3.1-3.3 COPPER alloyed	<650	200	0.075	0.1	0.085	0.12	0.12	0.16	0.16
4.1 MAGNESIUM alloyed	<250	500	0.09	0.12	0.1	0.14	0.14	0.18	0.18
5.1 PLASTICS Thermoplastic	<100	400	0.065	0.085	0.075	0.11	0.11	0.13	0.13
5.2 PLASTICS Duroplastic	<150	350	0.055	0.075	0.065	0.1	0.1	0.12	0.12

Cooling	
Tolerance	h6
Coating	AlphaSlide Rainbow

Strategy	ETC	HPC	
Application			
Features	HA	\neq	

- Defined clearance angle for ideal stabilization with high cutting depths
 - Special helical pitch for smooth running and soft cut
 - Extra large chip chambers for an extreme chip volume
- For process reliable, helical diving and immersion
 - For roughing and finishing, up to 2xD full slot

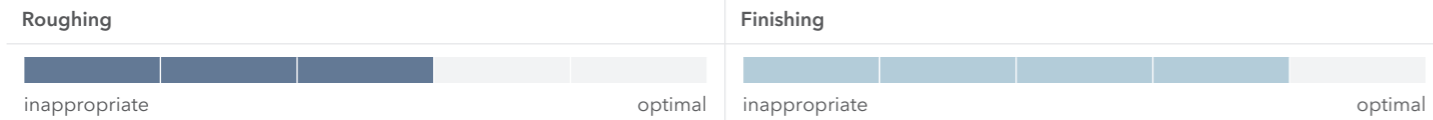
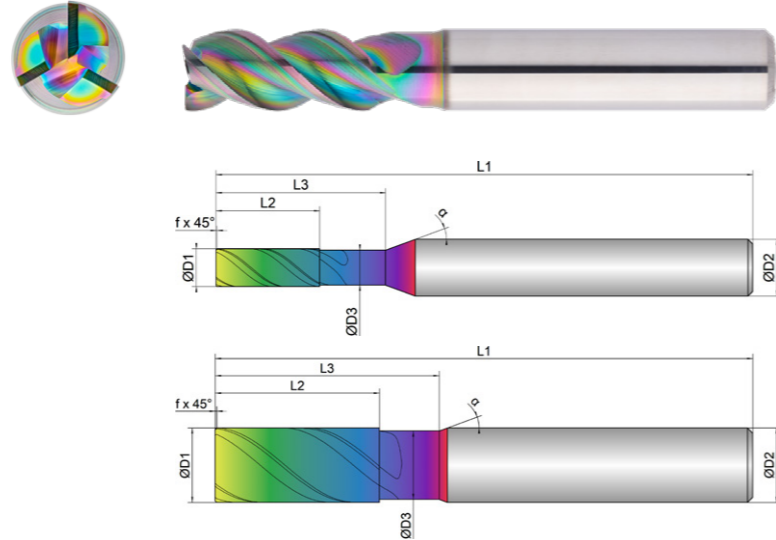

EXN1-M01-0103	D1	D3	L2	L3	L1	D2	z	α	α	
	mm \varnothing	mm \varnothing	mm	mm	mm	mm \varnothing	#	mm		
2	2.0	1.8	5.0	10.0	57.0	6.0	3	0.05	45	20
3	3.0	2.7	8.0	12.0	57.0	6.0	3	0.10	45	20
4	4.0	3.7	11.0	18.0	57.0	6.0	3	0.10	45	20
5	5.0	4.7	13.0	18.0	57.0	6.0	3	0.10	45	20
6	6.0	5.7	13.0	18.0	57.0	6.0	3	0.20	45	20
8	8.0	7.4	21.0	25.0	63.0	8.0	3	0.20	45	20
10	10.0	9.2	22.0	30.0	72.0	10.0	3	0.20	45	20
12	12.0	11.0	26.0	36.0	83.0	12.0	3	0.20	45	20
16	16.0	15.0	36.0	42.0	92.0	16.0	3	0.20	45	20
20	20.0	19.0	41.0	52.0	104.0	20.0	3	0.20	45	20



Download Catalog Pages (PDF)

Dimension	Ø2		Ø3		Ø4		Ø5		Ø6		Ø8	
Infeed in mm	ae=1xD	ae=0.3xD	ae=1xD	ae=0.3xD	ae=1xD	ae=0.3xD	ae=1xD	ae=0.3xD	ae=1xD	ae=0.3xD	ae=1xD	ae=0.3xD
Application												

N	Material	Strength (N/mm ²)	Feed (mm/Z)	Vc (m/min)											
				fz	fz	fz	fz	fz	fz	fz	fz	fz	fz	fz	fz
1.1	ALUMINIUM alloyed	<500	500	0.025	0.04	0.04	0.05	0.05	0.06	0.055	0.07	0.06	0.08	0.08	0.1
1.2	ALUMINIUM alloyed	<600	480	0.025	0.04	0.04	0.05	0.05	0.06	0.055	0.07	0.06	0.08	0.08	0.1
2.1-2.3	ALUMINIUM casted	<600	450	0.02	0.035	0.035	0.045	0.045	0.055	0.05	0.065	0.055	0.075	0.075	0.09
3.1-3.3	COPPER alloyed	<650	200	0.015	0.03	0.03	0.04	0.04	0.05	0.045	0.06	0.05	0.07	0.07	0.085
4.1	MAGNESIUM alloyed	<250	500	0.025	0.04	0.04	0.05	0.05	0.06	0.055	0.07	0.06	0.08	0.08	0.1
5.1	PLASTICS Thermoplastic	<100	400	0.015	0.03	0.03	0.04	0.04	0.045	0.04	0.05	0.045	0.065	0.055	0.065
5.2	PLASTICS Duroplastic	<150	350	0.012	0.025	0.025	0.035	0.03	0.035	0.035	0.04	0.035	0.055	0.045	0.055

Dimension	Ø10		Ø12		Ø16		Ø20	
Infeed in mm	ae=1xD	ae=0.3xD	ae=1xD	ae=0.3xD	ae=1xD	ae=0.3xD	ae=1xD	ae=0.3xD
Application								

N	Material	Strength (N/mm ²)	Feed (mm/Z)	Vc (m/min)							
				fz	fz	fz	fz	fz	fz	fz	fz
1.1	ALUMINIUM alloyed	<500	500	0.09	0.12	0.1	0.14	0.14	0.18	0.18	0.22
1.2	ALUMINIUM alloyed	<600	480	0.09	0.12	0.1	0.14	0.14	0.18	0.18	0.22
2.1-2.3	ALUMINIUM casted	<600	450	0.08	0.11	0.09	0.13	0.13	0.17	0.17	0.2
3.1-3.3	COPPER alloyed	<650	200	0.075	0.1	0.085	0.12	0.12	0.16	0.16	0.18
4.1	MAGNESIUM alloyed	<250	500	0.09	0.12	0.1	0.14	0.14	0.18	0.18	0.22
5.1	PLASTICS Thermoplastic	<100	400	0.065	0.085	0.075	0.11	0.11	0.13	0.13	0.17
5.2	PLASTICS Duroplastic	<150	350	0.055	0.075	0.065	0.1	0.1	0.12	0.12	0.16

Cooling	
Tolerance	h6
Coating	AlphaSlide Rainbow

Strategy	ETC	HPC	
Application			
Features	HB		

- Defined clearance angle for ideal stabilization with high cutting depths
 - Special helical pitch for smooth running and soft cut
 - Extra large chip chambers for an extreme chip volume
- For process reliable, helical diving and immersion
 - For roughing and finishing, up to 2xD full slot

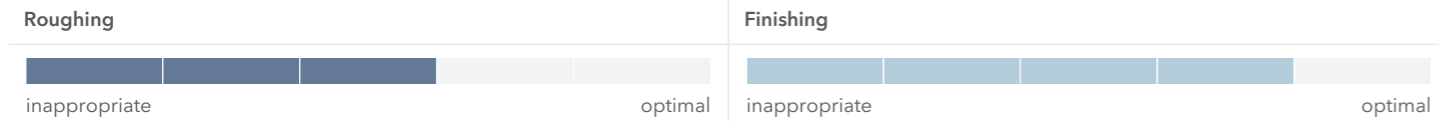
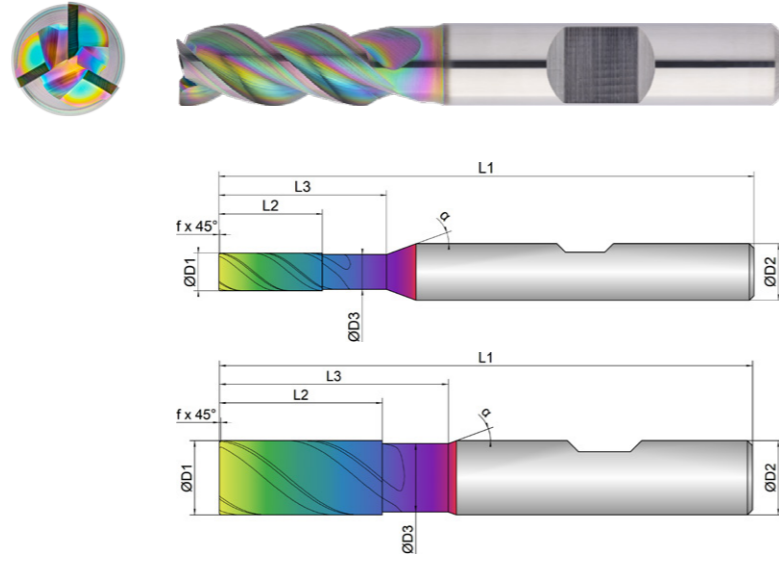

EXN1-M01-0104	D1	D3	L2	L3	L1	D2	z	45°		α
	mm Ø	mm Ø	mm	mm	mm	mm Ø	#			
2	2.0	1.8	5.0	10.0	57.0	6.0	3	0.05	45	20
3	3.0	2.7	8.0	12.0	57.0	6.0	3	0.10	45	20
4	4.0	3.7	11.0	18.0	57.0	6.0	3	0.10	45	20
5	5.0	4.7	13.0	18.0	57.0	6.0	3	0.10	45	20
6	6.0	5.7	13.0	18.0	57.0	6.0	3	0.20	45	20
8	8.0	7.4	21.0	25.0	63.0	8.0	3	0.20	45	20
10	10.0	9.2	22.0	30.0	72.0	10.0	3	0.20	45	20
12	12.0	11.0	26.0	36.0	83.0	12.0	3	0.20	45	20
16	16.0	15.0	36.0	42.0	92.0	16.0	3	0.20	45	20
20	20.0	19.0	41.0	52.0	104.0	20.0	3	0.20	45	20



Download Catalog Pages (PDF)

Dimension	Ø2		Ø3		Ø4		Ø5		Ø6		Ø8	
Infeed in mm	ae=1xD	ae=0.3xD	ae=1xD	ae=0.3xD	ae=1xD	ae=0.3xD	ae=1xD	ae=0.3xD	ae=1xD	ae=0.3xD	ae=1xD	ae=0.3xD
Application												

N	Material	Strength (N/mm ²)	Feed (mm/Z)	Vc (m/min)											
				fz	fz	fz	fz	fz	fz	fz	fz	fz	fz	fz	fz
1.1	ALUMINIUM alloyed	<500	500	0.025	0.04	0.04	0.05	0.05	0.06	0.055	0.07	0.06	0.08	0.08	0.1
1.2	ALUMINIUM alloyed	<600	480	0.025	0.04	0.04	0.05	0.05	0.06	0.055	0.07	0.06	0.08	0.08	0.1
2.1-2.3	ALUMINIUM casted	<600	450	0.02	0.035	0.035	0.045	0.045	0.055	0.05	0.065	0.055	0.075	0.075	0.09
3.1-3.3	COPPER alloyed	<650	200	0.015	0.03	0.03	0.04	0.04	0.05	0.045	0.06	0.05	0.07	0.07	0.085
4.1	MAGNESIUM alloyed	<250	500	0.025	0.04	0.04	0.05	0.05	0.06	0.055	0.07	0.06	0.08	0.08	0.1
5.1	PLASTICS Thermoplastic	<100	400	0.015	0.03	0.03	0.04	0.04	0.045	0.04	0.05	0.045	0.065	0.055	0.065
5.2	PLASTICS Duroplastic	<150	350	0.012	0.025	0.025	0.035	0.03	0.035	0.035	0.04	0.035	0.055	0.045	0.055

Dimension	Ø10		Ø12		Ø16		Ø20	
Infeed in mm	ae=1xD	ae=0.3xD	ae=1xD	ae=0.3xD	ae=1xD	ae=0.3xD	ae=1xD	ae=0.3xD
Application								

N	Material	Strength (N/mm ²)	Feed (mm/Z)	Vc (m/min)							
				fz	fz	fz	fz	fz	fz	fz	fz
1.1	ALUMINIUM alloyed	<500	500	0.09	0.12	0.1	0.14	0.14	0.18	0.18	0.22
1.2	ALUMINIUM alloyed	<600	480	0.09	0.12	0.1	0.14	0.14	0.18	0.18	0.22
2.1-2.3	ALUMINIUM casted	<600	450	0.08	0.11	0.09	0.13	0.13	0.17	0.17	0.2
3.1-3.3	COPPER alloyed	<650	200	0.075	0.1	0.085	0.12	0.12	0.16	0.16	0.18
4.1	MAGNESIUM alloyed	<250	500	0.09	0.12	0.1	0.14	0.14	0.18	0.18	0.22
5.1	PLASTICS Thermoplastic	<100	400	0.065	0.085	0.075	0.11	0.11	0.13	0.13	0.17
5.2	PLASTICS Duroplastic	<150	350	0.055	0.075	0.065	0.1	0.1	0.12	0.12	0.16

Cooling	
Tolerance	h6
Coating	AlphaSlide Rainbow

Strategy	ETC	HPC	
Application			
Features	HA	≠	

- Defined clearance angle for ideal stabilization with high cutting depths
 - Special helical pitch for smooth running and soft cut
 - Extra large chip chambers for an extreme chip volume
- For process reliable, helical diving and immersion
 - For roughing and finishing
- Long version for deeper cavities

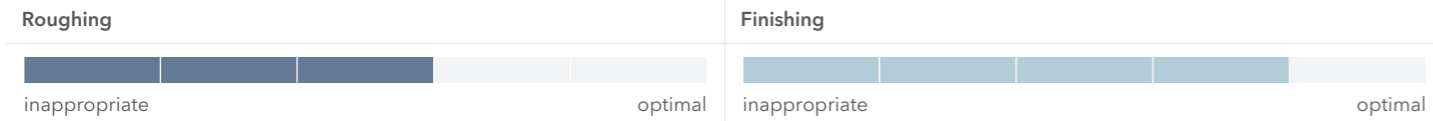
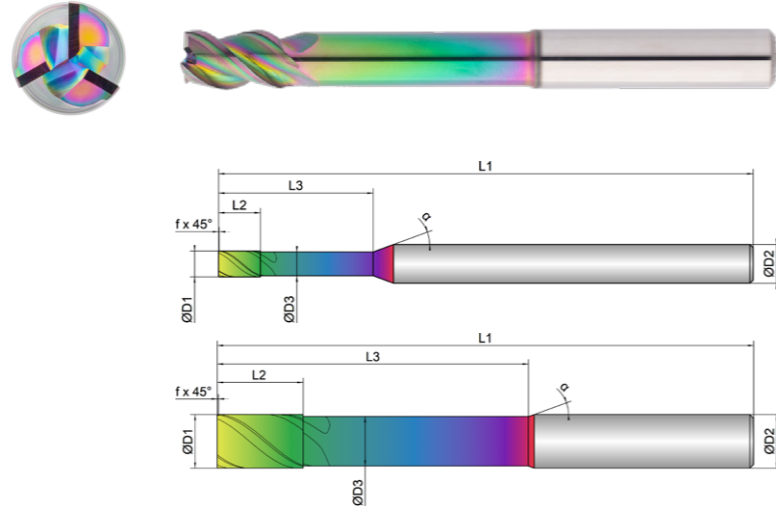

EXN1-M01-0113	D1	D3	L2	L3	L1	D2	z	45°		α
	mm ø	mm ø	mm	mm	mm	mm ø	#	mm	°	°
2	2.0	1.8	4.0	13.0	83.0	6.0	3	0.05	45	20
3	3.0	2.7	5.0	18.0	83.0	6.0	3	0.10	45	20
4	4.0	3.7	6.5	24.0	83.0	6.0	3	0.10	45	20
5	5.0	4.7	8.0	30.0	83.0	6.0	3	0.10	45	20
6	6.0	5.7	10.0	42.0	83.0	6.0	3	0.20	45	20
8	8.0	7.4	13.0	62.0	100.0	8.0	3	0.20	45	20
10	10.0	9.2	16.0	58.0	100.0	10.0	3	0.20	45	20
12	12.0	11.0	19.0	73.0	120.0	12.0	3	0.20	45	20
16	16.0	15.0	25.0	100.0	150.0	16.0	3	0.20	45	20
20	20.0	19.0	32.0	98.0	150.0	20.0	3	0.20	45	20



Download Catalog Pages (PDF)

Dimension	Ø2		Ø3		Ø4		Ø5		Ø6		Ø8	
Infeed in mm	ae=1xD	ae=0.3xD	ae=1xD	ae=0.3xD	ae=1xD	ae=0.3xD	ae=1xD	ae=0.3xD	ae=1xD	ae=0.3xD	ae=1xD	ae=0.3xD
Application												

Material	Strength (N/mm ²)	Feed (mm/Z)	fz	fz	fz	fz	fz	fz	fz	fz	fz	fz	fz	
N NON-FERROUS		Vc (m/min)												
1.1 ALUMINIUM alloyed	<500	280	0.012	0.03	0.02	0.04	0.025	0.05	0.035	0.065	0.04	0.065	0.045	0.075
1.2 ALUMINIUM alloyed	<600	260	0.012	0.03	0.02	0.04	0.025	0.05	0.035	0.065	0.04	0.065	0.045	0.075
2.1-2.3 ALUMINIUM casted	<600	240	0.01	0.025	0.015	0.035	0.02	0.045	0.03	0.055	0.035	0.055	0.04	0.065
3.1-3.3 COPPER alloyed	<650	120	0.008	0.02	0.012	0.03	0.015	0.035	0.025	0.045	0.03	0.045	0.035	0.055
4.1 MAGNESIUM alloyed	<250	280	0.012	0.03	0.02	0.04	0.025	0.05	0.035	0.065	0.04	0.065	0.045	0.075
5.1 PLASTICS Thermoplastic	<100	200	0.01	0.025	0.015	0.035	0.02	0.045	0.03	0.055	0.035	0.055	0.04	0.065
5.2 PLASTICS Duroplastic	<150	170	0.008	0.02	0.012	0.03	0.015	0.035	0.025	0.045	0.03	0.045	0.035	0.055

Dimension	Ø10		Ø12		Ø16		Ø20	
Infeed in mm	ae=1xD	ae=0.3xD	ae=1xD	ae=0.3xD	ae=1xD	ae=0.3xD	ae=1xD	ae=0.3xD
Application								

Material	Strength (N/mm ²)	Feed (mm/Z)	fz	fz	fz	fz	fz	fz	fz	
N NON-FERROUS		Vc (m/min)								
1.1 ALUMINIUM alloyed	<500	280	0.05	0.09	0.05	0.1	0.06	0.12	0.07	0.14
1.2 ALUMINIUM alloyed	<600	260	0.05	0.09	0.05	0.1	0.06	0.12	0.07	0.14
2.1-2.3 ALUMINIUM casted	<600	240	0.045	0.08	0.045	0.09	0.055	0.11	0.065	0.13
3.1-3.3 COPPER alloyed	<650	120	0.04	0.07	0.04	0.08	0.05	0.1	0.06	0.12
4.1 MAGNESIUM alloyed	<250	280	0.05	0.09	0.05	0.1	0.06	0.12	0.07	0.14
5.1 PLASTICS Thermoplastic	<100	200	0.045	0.08	0.045	0.09	0.055	0.11	0.065	0.13
5.2 PLASTICS Duroplastic	<150	170	0.04	0.07	0.04	0.08	0.05	0.1	0.06	0.12

Cooling

Tolerance h6

Coating AlphaSlide Rainbow

Strategy ETC HPC

Application

Features HB ≠

- Defined clearance angle for ideal stabilization with high cutting depths
 - Special helical pitch for smooth running and soft cut
 - Extra large chip chambers for an extreme chip volume
-
- For process reliable, helical diving and immersion
 - For roughing and finishing
-
- Long version for deeper cavities

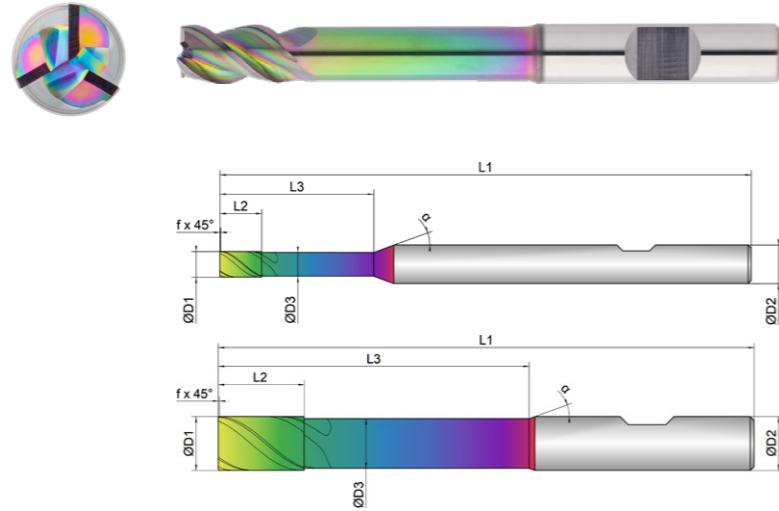

Roughing

Finishing

EXN1-M01-0114	D1	D3	L2	L3	L1	D2	z	45°	°	α
	mm ∅	mm ∅	mm	mm	mm	mm ∅	#	mm	°	°
2	2.0	1.8	4.0	13.0	83.0	6.0	3	0.05	45	20
3	3.0	2.7	5.0	18.0	83.0	6.0	3	0.10	45	20
4	4.0	3.7	6.5	24.0	83.0	6.0	3	0.10	45	20
5	5.0	4.7	8.0	30.0	83.0	6.0	3	0.10	45	20
6	6.0	5.7	10.0	42.0	83.0	6.0	3	0.20	45	20
8	8.0	7.4	13.0	62.0	100.0	8.0	3	0.20	45	20
10	10.0	9.2	16.0	58.0	100.0	10.0	3	0.20	45	20
12	12.0	11.0	19.0	73.0	120.0	12.0	3	0.20	45	20
16	16.0	15.0	25.0	100.0	150.0	16.0	3	0.20	45	20
20	20.0	19.0	32.0	98.0	150.0	20.0	3	0.20	45	20



Download Catalog Pages (PDF)

Dimension	Ø2		Ø3		Ø4		Ø5		Ø6		Ø8	
Infeed in mm	ae=1xD	ae=0.3xD	ae=1xD	ae=0.3xD	ae=1xD	ae=0.3xD	ae=1xD	ae=0.3xD	ae=1xD	ae=0.3xD	ae=1xD	ae=0.3xD
Application												

Material	Strength (N/mm ²)	Feed (mm/Z)	fz	fz	fz	fz	fz	fz	fz	fz	fz	fz	fz	
N NON-FERROUS		Vc (m/min)												
1.1 ALUMINIUM alloyed	<500	280	0.012	0.03	0.02	0.04	0.025	0.05	0.035	0.065	0.04	0.065	0.045	0.075
1.2 ALUMINIUM alloyed	<600	260	0.012	0.03	0.02	0.04	0.025	0.05	0.035	0.065	0.04	0.065	0.045	0.075
2.1-2.3 ALUMINIUM casted	<600	240	0.01	0.025	0.015	0.035	0.02	0.045	0.03	0.055	0.035	0.055	0.04	0.065
3.1-3.3 COPPER alloyed	<650	120	0.008	0.02	0.012	0.03	0.015	0.035	0.025	0.045	0.03	0.045	0.035	0.055
4.1 MAGNESIUM alloyed	<250	280	0.012	0.03	0.02	0.04	0.025	0.05	0.035	0.065	0.04	0.065	0.045	0.075
5.1 PLASTICS Thermoplastic	<100	200	0.01	0.025	0.015	0.035	0.02	0.045	0.03	0.055	0.035	0.055	0.04	0.065
5.2 PLASTICS Duroplastic	<150	170	0.008	0.02	0.012	0.03	0.015	0.035	0.025	0.045	0.03	0.045	0.035	0.055

Dimension	Ø10		Ø12		Ø16		Ø20	
Infeed in mm	ae=1xD	ae=0.3xD	ae=1xD	ae=0.3xD	ae=1xD	ae=0.3xD	ae=1xD	ae=0.3xD
Application								

Material	Strength (N/mm ²)	Feed (mm/Z)	fz	fz	fz	fz	fz	fz	fz	
N NON-FERROUS		Vc (m/min)								
1.1 ALUMINIUM alloyed	<500	280	0.05	0.09	0.05	0.1	0.06	0.12	0.07	0.14
1.2 ALUMINIUM alloyed	<600	260	0.05	0.09	0.05	0.1	0.06	0.12	0.07	0.14
2.1-2.3 ALUMINIUM casted	<600	240	0.045	0.08	0.045	0.09	0.055	0.11	0.065	0.13
3.1-3.3 COPPER alloyed	<650	120	0.04	0.07	0.04	0.08	0.05	0.1	0.06	0.12
4.1 MAGNESIUM alloyed	<250	280	0.05	0.09	0.05	0.1	0.06	0.12	0.07	0.14
5.1 PLASTICS Thermoplastic	<100	200	0.045	0.08	0.045	0.09	0.055	0.11	0.065	0.13
5.2 PLASTICS Duroplastic	<150	170	0.04	0.07	0.04	0.08	0.05	0.1	0.06	0.12

Cooling	
Tolerance	h6
Coating	AlphaSlide Rainbow

Strategy	ETC	HPC	
Application			
Features	HA	≠	3xD

- Defined clearance angle for ideal stabilization with high cutting depths
 - Special helical pitch for smooth running and soft cut
 - Extra large chip chambers for an extreme chip volume
- For process reliable, helical diving and immersion
 - For roughing and finishing

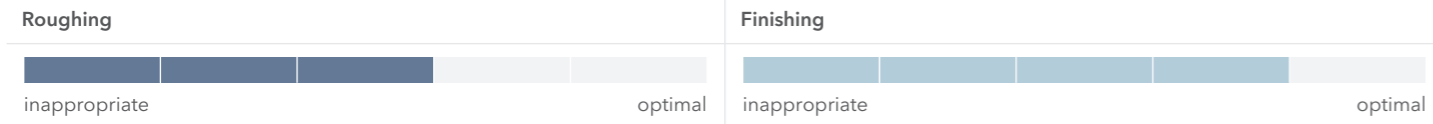
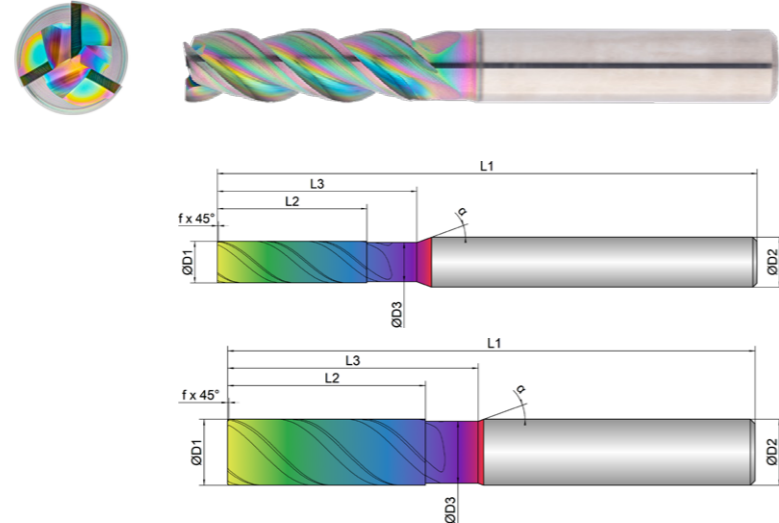

EXN1-M01-0123	D1	D3	L2	L3	L1	D2	z	45°	α	
	mm	mm	mm	mm	mm	mm	#	mm	°	
2	2.0	1.8	7.0	12.0	65.0	6.0	3	0.05	45	20
3	3.0	2.7	10.0	14.0	65.0	6.0	3	0.10	45	20
4	4.0	3.7	13.0	18.0	65.0	6.0	3	0.10	45	20
5	5.0	4.7	18.0	24.0	65.0	6.0	3	0.10	45	20
6	6.0	5.5	20.0	24.0	65.0	6.0	3	0.20	45	20
8	8.0	7.5	26.0	30.0	70.0	8.0	3	0.20	45	20
10	10.0	9.4	30.0	38.0	80.0	10.0	3	0.20	45	20
12	12.0	11.4	36.0	46.0	93.0	12.0	3	0.20	45	20
16	16.0	15.4	48.0	58.0	110.0	16.0	3	0.20	45	20
20	20.0	19.4	60.0	74.0	125.0	20.0	3	0.20	45	20



Download Catalog Pages (PDF)

Dimension	Ø2		Ø3		Ø4		Ø5		Ø6		Ø8	
Infeed in mm	ae=1xD	ae=0.3xD	ae=1xD	ae=0.3xD	ae=1xD	ae=0.3xD	ae=1xD	ae=0.3xD	ae=1xD	ae=0.3xD	ae=1xD	ae=0.3xD
Application												

Material	Strength (N/mm ²)	Feed (mm/Z)	fz	fz	fz	fz	fz	fz	fz	fz	fz	fz	fz	fz
N NON-FERROUS		Vc (m/min)												
1.1 ALUMINIUM alloyed	<500	500	0.02	0.03	0.025	0.04	0.035	0.05	0.045	0.06	0.05	0.07	0.07	0.09
1.2 ALUMINIUM alloyed	<600	480	0.02	0.03	0.025	0.04	0.035	0.05	0.045	0.06	0.05	0.07	0.07	0.09
2.1-2.3 ALUMINIUM casted	<600	450	0.015	0.025	0.02	0.035	0.03	0.045	0.04	0.055	0.045	0.065	0.06	0.08
3.1-3.3 COPPER alloyed	<650	200	0.012	0.02	0.015	0.03	0.025	0.04	0.035	0.05	0.04	0.06	0.05	0.07
4.1 MAGNESIUM alloyed	<250	500	0.02	0.03	0.025	0.04	0.035	0.05	0.045	0.06	0.05	0.07	0.07	0.09
5.1 PLASTICS Thermoplastic	<100	400	0.015	0.02	0.015	0.03	0.025	0.04	0.03	0.045	0.04	0.06	0.05	0.06
5.2 PLASTICS Duroplastic	<150	350	0.012	0.015	0.012	0.025	0.02	0.035	0.025	0.04	0.035	0.055	0.04	0.05

Dimension	Ø10		Ø12		Ø16		Ø20	
Infeed in mm	ae=1xD	ae=0.3xD	ae=1xD	ae=0.3xD	ae=1xD	ae=0.3xD	ae=1xD	ae=0.3xD
Application								

Material	Strength (N/mm ²)	Feed (mm/Z)	fz	fz	fz	fz	fz	fz	fz	
N NON-FERROUS		Vc (m/min)								
1.1 ALUMINIUM alloyed	<500	500	0.08	0.11	0.09	0.13	0.13	0.16	0.16	0.2
1.2 ALUMINIUM alloyed	<600	480	0.08	0.11	0.09	0.13	0.13	0.16	0.16	0.2
2.1-2.3 ALUMINIUM casted	<600	450	0.07	0.1	0.08	0.12	0.12	0.15	0.15	0.19
3.1-3.3 COPPER alloyed	<650	200	0.06	0.09	0.07	0.11	0.11	0.14	0.14	0.18
4.1 MAGNESIUM alloyed	<250	500	0.08	0.11	0.09	0.13	0.13	0.16	0.16	0.2
5.1 PLASTICS Thermoplastic	<100	400	0.06	0.08	0.07	0.1	0.1	0.13	0.13	0.17
5.2 PLASTICS Duroplastic	<150	350	0.05	0.07	0.06	0.09	0.09	0.12	0.12	0.16

Cooling

Tolerance h6

Coating AlphaSlide Rainbow

Strategy ETC HPC

Application

Features HB ≠ 3xD

- Defined clearance angle for ideal stabilization with high cutting depths
 - Special helical pitch for smooth running and soft cut
 - Extra large chip chambers for an extreme chip volume
- For process reliable, helical diving and immersion
 - For roughing and finishing

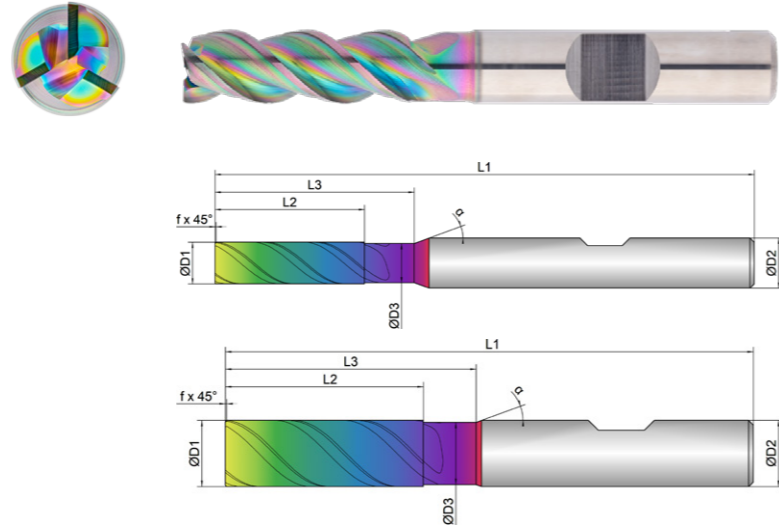

Roughing **Finishing**

EXN1-M01-0124	D1	D3	L2	L3	L1	D2	z	α	α
	mm	mm	mm	mm	mm	mm	#	mm	°
2	2.0	1.8	7.0	12.0	65.0	6.0	3	0.05	45
3	3.0	2.7	10.0	14.0	65.0	6.0	3	0.10	45
4	4.0	3.7	13.0	18.0	65.0	6.0	3	0.10	45
5	5.0	4.7	18.0	24.0	65.0	6.0	3	0.10	45
6	6.0	5.5	20.0	24.0	65.0	6.0	3	0.20	45
8	8.0	7.5	26.0	30.0	70.0	8.0	3	0.20	45
10	10.0	9.4	30.0	38.0	80.0	10.0	3	0.20	45
12	12.0	11.4	36.0	46.0	93.0	12.0	3	0.20	45
16	16.0	15.4	48.0	58.0	110.0	16.0	3	0.20	45
20	20.0	19.4	60.0	74.0	125.0	20.0	3	0.20	45



Download Catalog Pages (PDF)

Dimension	Ø2		Ø3		Ø4		Ø5		Ø6		Ø8	
Infeed in mm	ae=1xD	ae=0.3xD	ae=1xD	ae=0.3xD	ae=1xD	ae=0.3xD	ae=1xD	ae=0.3xD	ae=1xD	ae=0.3xD	ae=1xD	ae=0.3xD
Application												

N	Material	Strength (N/mm ²)	Feed (mm/Z)	fz											
				Vc (m/min)											
1.1	ALUMINIUM alloyed	<500	500	0.02	0.03	0.025	0.04	0.035	0.05	0.045	0.06	0.05	0.07	0.07	0.09
1.2	ALUMINIUM alloyed	<600	480	0.02	0.03	0.025	0.04	0.035	0.05	0.045	0.06	0.05	0.07	0.07	0.09
2.1-2.3	ALUMINIUM casted	<600	450	0.015	0.025	0.02	0.035	0.03	0.045	0.04	0.055	0.045	0.065	0.06	0.08
3.1-3.3	COPPER alloyed	<650	200	0.012	0.02	0.015	0.03	0.025	0.04	0.035	0.05	0.04	0.06	0.05	0.07
4.1	MAGNESIUM alloyed	<250	500	0.02	0.03	0.025	0.04	0.035	0.05	0.045	0.06	0.05	0.07	0.07	0.09
5.1	PLASTICS Thermoplastic	<100	400	0.015	0.02	0.015	0.03	0.025	0.04	0.03	0.045	0.04	0.06	0.05	0.06
5.2	PLASTICS Duroplastic	<150	350	0.012	0.015	0.012	0.025	0.02	0.035	0.025	0.04	0.035	0.055	0.04	0.05

Dimension	Ø10		Ø12		Ø16		Ø20	
Infeed in mm	ae=1xD	ae=0.3xD	ae=1xD	ae=0.3xD	ae=1xD	ae=0.3xD	ae=1xD	ae=0.3xD
Application								

N	Material	Strength (N/mm ²)	Feed (mm/Z)	fz							
				Vc (m/min)							
1.1	ALUMINIUM alloyed	<500	500	0.08	0.11	0.09	0.13	0.13	0.16	0.16	0.2
1.2	ALUMINIUM alloyed	<600	480	0.08	0.11	0.09	0.13	0.13	0.16	0.16	0.2
2.1-2.3	ALUMINIUM casted	<600	450	0.07	0.1	0.08	0.12	0.12	0.15	0.15	0.19
3.1-3.3	COPPER alloyed	<650	200	0.06	0.09	0.07	0.11	0.11	0.14	0.14	0.18
4.1	MAGNESIUM alloyed	<250	500	0.08	0.11	0.09	0.13	0.13	0.16	0.16	0.2
5.1	PLASTICS Thermoplastic	<100	400	0.06	0.08	0.07	0.1	0.1	0.13	0.13	0.17
5.2	PLASTICS Duroplastic	<150	350	0.05	0.07	0.06	0.09	0.09	0.12	0.12	0.16

Cooling

Tolerance h6

Coating AlphaSlide Rainbow

Strategy ETC HPC

Application

Features HA ≠ 3xD

- Defined clearance angle for ideal stabilization with high cutting depths
 - Special helical pitch for smooth running and soft cut
 - Extra large chip chambers for an extreme chip volume
- For process reliable, helical diving and immersion
 - For roughing and finishing
- Sharp-edged version without edge protection

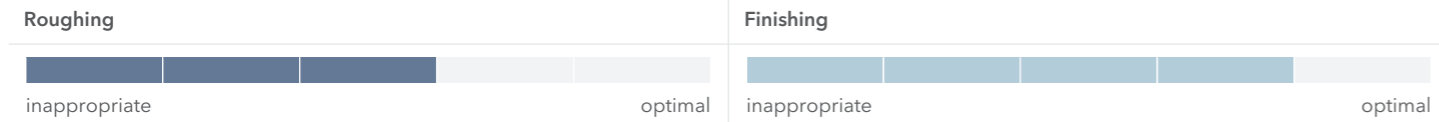
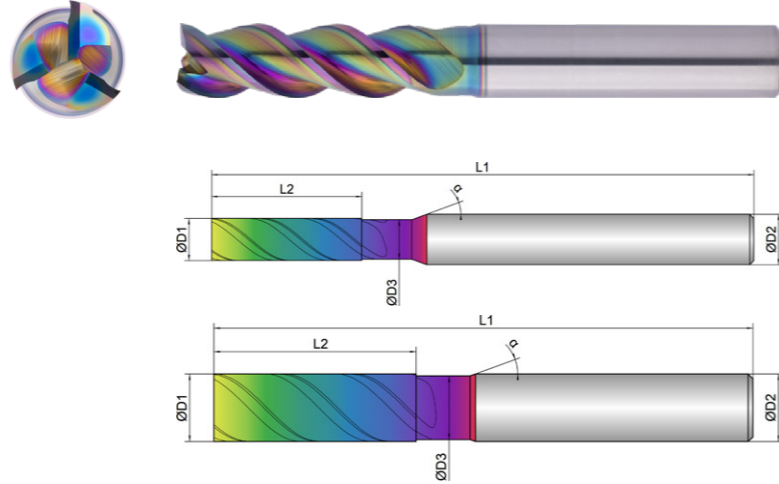

	D1	D3	L2	L3	L1	D2	z	α	
EXN1-M01-0133	mm Ø	mm Ø	mm	mm	mm	mm Ø	#	°	
2	2.0	1.8	7.0	12.0	65.0	6.0	3	45	20
3	3.0	2.7	10.0	14.0	65.0	6.0	3	45	20
4	4.0	3.7	13.0	18.0	65.0	6.0	3	45	20
5	5.0	4.7	18.0	24.0	65.0	6.0	3	45	20
6	6.0	5.5	20.0	24.0	65.0	6.0	3	45	20
8	8.0	7.5	26.0	30.0	70.0	8.0	3	45	20
10	10.0	9.4	30.0	38.0	80.0	10.0	3	45	20
12	12.0	11.4	36.0	46.0	93.0	12.0	3	45	20
16	16.0	15.4	48.0	58.0	110.0	16.0	3	45	20
20	20.0	19.4	60.0	74.0	125.0	20.0	3	45	20



Download Catalog Pages (PDF)

Dimension	Ø2		Ø3		Ø4		Ø5		Ø6		Ø8	
Infeed in mm	ae=1xD	ae=0.3xD	ae=1xD	ae=0.3xD	ae=1xD	ae=0.3xD	ae=1xD	ae=0.3xD	ae=1xD	ae=0.3xD	ae=1xD	ae=0.3xD
Application												

Material	Strength (N/mm ²)	Feed (mm/Z)	fz	fz	fz	fz	fz	fz	fz	fz	fz	fz	fz	fz	
N	NON-FERROUS	Vc (m/min)													
1.1	ALUMINIUM alloyed	<500	500	0.02	0.03	0.025	0.04	0.035	0.05	0.045	0.06	0.05	0.07	0.07	0.09
1.2	ALUMINIUM alloyed	<600	480	0.02	0.03	0.025	0.04	0.035	0.05	0.045	0.06	0.05	0.07	0.07	0.09
2.1-2.3	ALUMINIUM casted	<600	450	0.015	0.025	0.02	0.035	0.03	0.045	0.04	0.055	0.045	0.065	0.06	0.08
3.1-3.3	COPPER alloyed	<650	200	0.012	0.02	0.015	0.03	0.025	0.04	0.035	0.05	0.04	0.06	0.05	0.07
4.1	MAGNESIUM alloyed	<250	500	0.02	0.03	0.025	0.04	0.035	0.05	0.045	0.06	0.05	0.07	0.07	0.09
5.1	PLASTICS Thermoplastic	<100	400	0.015	0.02	0.015	0.03	0.025	0.04	0.03	0.045	0.04	0.06	0.05	0.06
5.2	PLASTICS Duroplastic	<150	350	0.012	0.015	0.012	0.025	0.02	0.035	0.025	0.04	0.035	0.055	0.04	0.05

Dimension	Ø10		Ø12		Ø16		Ø20	
Infeed in mm	ae=1xD	ae=0.3xD	ae=1xD	ae=0.3xD	ae=1xD	ae=0.3xD	ae=1xD	ae=0.3xD
Application								

Material	Strength (N/mm ²)	Feed (mm/Z)	fz	fz	fz	fz	fz	fz	fz		
N	NON-FERROUS	Vc (m/min)									
1.1	ALUMINIUM alloyed	<500	500	0.08	0.11	0.09	0.13	0.13	0.16	0.16	0.2
1.2	ALUMINIUM alloyed	<600	480	0.08	0.11	0.09	0.13	0.13	0.16	0.16	0.2
2.1-2.3	ALUMINIUM casted	<600	450	0.07	0.1	0.08	0.12	0.12	0.15	0.15	0.19
3.1-3.3	COPPER alloyed	<650	200	0.06	0.09	0.07	0.11	0.11	0.14	0.14	0.18
4.1	MAGNESIUM alloyed	<250	500	0.08	0.11	0.09	0.13	0.13	0.16	0.16	0.2
5.1	PLASTICS Thermoplastic	<100	400	0.06	0.08	0.07	0.1	0.1	0.13	0.13	0.17
5.2	PLASTICS Duroplastic	<150	350	0.05	0.07	0.06	0.09	0.09	0.12	0.12	0.16

Cooling

Tolerance h6

Coating AlphaSlide Rainbow

Strategy ETC HPC

Application

Features HB ≠



Download Catalog Pages (PDF)

- Defined clearance angle for ideal stabilization with high cutting depths
 - Special helical pitch for smooth running and soft cut
 - Extra large chip chambers for an extreme chip volume
- For process reliable, helical diving and immersion
 - For roughing and finishing
- Sharp-edged version without edge protection

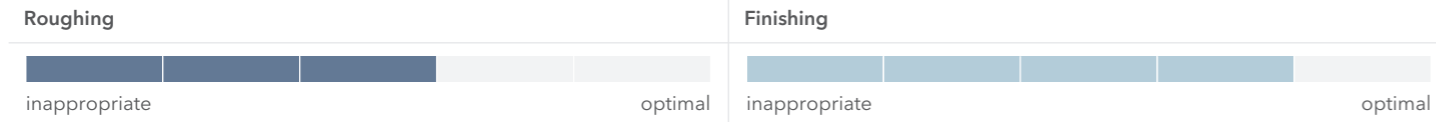
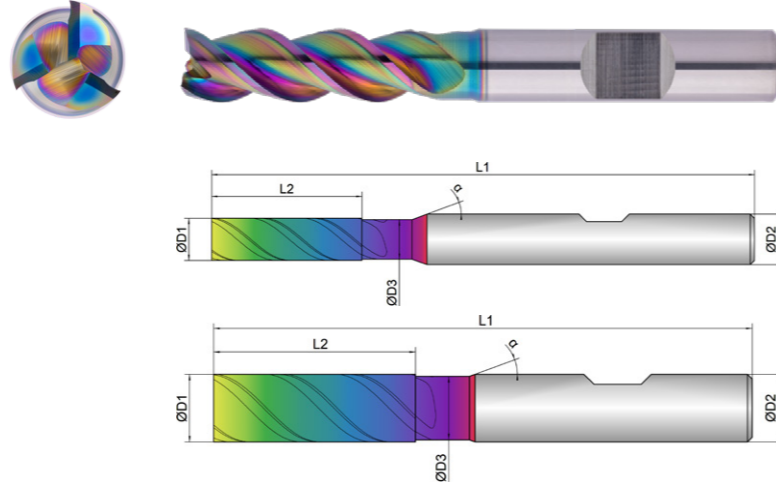

EXN1-M01-0134	D1 mm ø	D3 mm ø	L2 mm	L3 mm	L1 mm	D2 mm ø	z #		α °
2	2.0	1.8	7.0	12.0	65.0	6.0	3	45	20
3	3.0	2.7	10.0	14.0	65.0	6.0	3	45	20
4	4.0	3.7	13.0	18.0	65.0	6.0	3	45	20
5	5.0	4.7	18.0	24.0	65.0	6.0	3	45	20
6	6.0	5.5	20.0	24.0	65.0	6.0	3	45	20
8	8.0	7.5	26.0	30.0	70.0	8.0	3	45	20
10	10.0	9.4	30.0	38.0	80.0	10.0	3	45	20
12	12.0	11.4	36.0	46.0	93.0	12.0	3	45	20
16	16.0	15.4	48.0	58.0	110.0	16.0	3	45	20
20	20.0	19.4	60.0	74.0	125.0	20.0	3	45	20

Dimension	Ø2		Ø3		Ø4		Ø5		Ø6		Ø8	
Infeed in mm	ae=1xD	ae=0.3xD	ae=1xD	ae=0.3xD	ae=1xD	ae=0.3xD	ae=1xD	ae=0.3xD	ae=1xD	ae=0.3xD	ae=1xD	ae=0.3xD
Application												

N	Material	Strength (N/mm ²)	Feed (mm/Z)	fz	fz	fz	fz	fz	fz	fz	fz	fz	fz	fz	
NON-FERROUS			Vc (m/min)												
1.1	ALUMINIUM alloyed	<500	500	0.02	0.03	0.025	0.04	0.035	0.05	0.045	0.06	0.05	0.07	0.07	0.09
1.2	ALUMINIUM alloyed	<600	480	0.02	0.03	0.025	0.04	0.035	0.05	0.045	0.06	0.05	0.07	0.07	0.09
2.1-2.3	ALUMINIUM casted	<600	450	0.015	0.025	0.02	0.035	0.03	0.045	0.04	0.055	0.045	0.065	0.06	0.08
3.1-3.3	COPPER alloyed	<650	200	0.012	0.02	0.015	0.03	0.025	0.04	0.035	0.05	0.04	0.06	0.05	0.07
4.1	MAGNESIUM alloyed	<250	500	0.02	0.03	0.025	0.04	0.035	0.05	0.045	0.06	0.05	0.07	0.07	0.09
5.1	PLASTICS Thermoplastic	<100	400	0.015	0.02	0.015	0.03	0.025	0.04	0.03	0.045	0.04	0.06	0.05	0.06
5.2	PLASTICS Duroplastic	<150	350	0.012	0.015	0.012	0.025	0.02	0.035	0.025	0.04	0.035	0.055	0.04	0.05

Dimension	Ø10		Ø12		Ø16		Ø20	
Infeed in mm	ae=1xD	ae=0.3xD	ae=1xD	ae=0.3xD	ae=1xD	ae=0.3xD	ae=1xD	ae=0.3xD
Application								

N	Material	Strength (N/mm ²)	Feed (mm/Z)	fz	fz	fz	fz	fz	fz	fz	fz	
NON-FERROUS			Vc (m/min)									
1.1	ALUMINIUM alloyed	<500	500	0.08	0.11	0.09	0.13	0.13	0.16	0.16	0.2	
1.2	ALUMINIUM alloyed	<600	480	0.08	0.11	0.09	0.13	0.13	0.16	0.16	0.2	
2.1-2.3	ALUMINIUM casted	<600	450	0.07	0.1	0.08	0.12	0.12	0.15	0.15	0.19	
3.1-3.3	COPPER alloyed	<650	200	0.06	0.09	0.07	0.11	0.11	0.14	0.14	0.18	
4.1	MAGNESIUM alloyed	<250	500	0.08	0.11	0.09	0.13	0.13	0.16	0.16	0.2	
5.1	PLASTICS Thermoplastic	<100	400	0.06	0.08	0.07	0.1	0.1	0.13	0.13	0.17	
5.2	PLASTICS Duroplastic	<150	350	0.05	0.07	0.06	0.09	0.09	0.12	0.12	0.16	

Cooling	
Tolerance	h6
Coating	AlphaSlide Rainbow

Strategy	ETC	HPC	
Application			
Features	HA	≠	

- Defined clearance angle for ideal stabilization with high cutting depths
 - Special helical pitch for smooth running and soft cut
 - Extra large chip chambers for an extreme chip volume
- For process reliable, helical diving and immersion
 - For roughing and finishing, up to 2xD full slot
- With central inner cooling

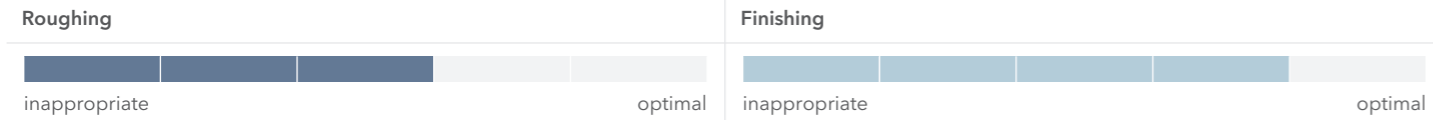
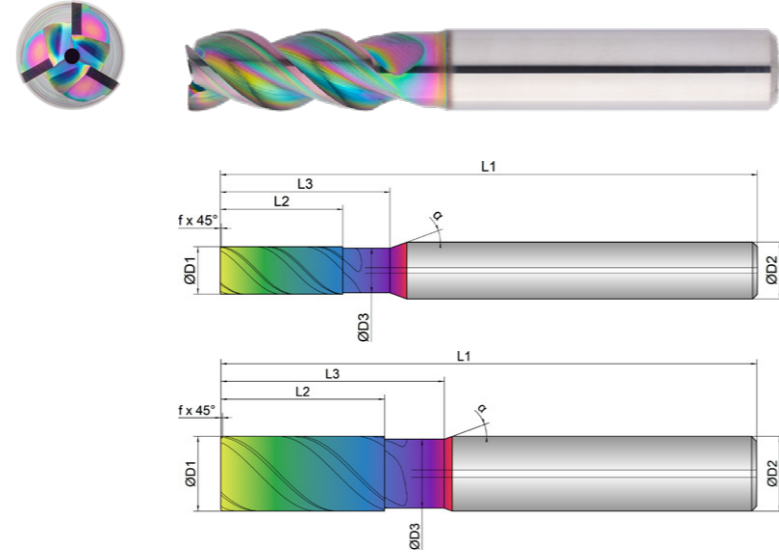

EXN1-M01-0203	D1	D3	L2	L3	L1	D2	z	45°	°	α
	mm ∅	mm ∅	mm	mm	mm	mm ∅	#	mm	°	°
5	5.0	4.7	13.0	18.0	57.0	6.0	3	0.10	45	20
6	6.0	5.7	13.0	18.0	57.0	6.0	3	0.20	45	20
8	8.0	7.4	21.0	25.0	63.0	8.0	3	0.20	45	20
10	10.0	9.2	22.0	30.0	72.0	10.0	3	0.20	45	20
12	12.0	11.0	26.0	36.0	83.0	12.0	3	0.20	45	20
16	16.0	15.0	36.0	42.0	92.0	16.0	3	0.20	45	20
20	20.0	19.0	41.0	52.0	104.0	20.0	3	0.20	45	20



Download Catalog Pages (PDF)

Dimension	Ø5		Ø6		Ø8		Ø10		Ø12		Ø16	
Infeed in mm	ae=1xD	ae=0.3xD	ae=1xD	ae=0.3xD	ae=1xD	ae=0.3xD	ae=1xD	ae=0.3xD	ae=1xD	ae=0.3xD	ae=1xD	ae=0.3xD
Application												

N	Material	Strength (N/mm²)	Feed (mm/Z)	Feed (mm/Z)													
				fz	fz	fz	fz	fz	fz	fz	fz	fz	fz	fz	fz	fz	fz
NON-FERROUS																	
1.1	ALUMINIUM alloyed	<500	500	0.055	0.07	0.06	0.08	0.08	0.1	0.09	0.12	0.1	0.14	0.14	0.18		
1.2	ALUMINIUM alloyed	<600	480	0.055	0.07	0.06	0.08	0.08	0.1	0.09	0.12	0.1	0.14	0.14	0.18		
2.1-2.3	ALUMINIUM casted	<600	450	0.05	0.065	0.055	0.075	0.075	0.09	0.08	0.11	0.09	0.13	0.13	0.17		
3.1-3.3	COPPER alloyed	<650	200	0.045	0.06	0.05	0.07	0.07	0.085	0.075	0.1	0.085	0.12	0.12	0.16		
4.1	MAGNESIUM alloyed	<250	500	0.055	0.07	0.06	0.08	0.08	0.1	0.09	0.12	0.1	0.14	0.14	0.18		
5.1	PLASTICS Thermoplastic	<100	400	0.04	0.05	0.045	0.065	0.055	0.065	0.065	0.085	0.075	0.11	0.11	0.13		
5.2	PLASTICS Duroplastic	<150	350	0.035	0.04	0.035	0.055	0.045	0.055	0.055	0.075	0.065	0.1	0.1	0.12		

Dimension	Ø20	
Infeed in mm	ae=1xD	ae=0.3xD
Application	ap=1xD	ap=2xD

N	Material	Strength (N/mm²)	Feed (mm/Z)	Feed (mm/Z)	
				fz	fz
NON-FERROUS					
1.1	ALUMINIUM alloyed	<500	500	0.18	0.22
1.2	ALUMINIUM alloyed	<600	480	0.18	0.22
2.1-2.3	ALUMINIUM casted	<600	450	0.17	0.2
3.1-3.3	COPPER alloyed	<650	200	0.16	0.18
4.1	MAGNESIUM alloyed	<250	500	0.18	0.22
5.1	PLASTICS Thermoplastic	<100	400	0.13	0.17
5.2	PLASTICS Duroplastic	<150	350	0.12	0.16

Cooling

Tolerance h6

Coating AlphaSlide Rainbow

Strategy ETC HPC

Application

Features HB ≠

- Defined clearance angle for ideal stabilization with high cutting depths
 - Special helical pitch for smooth running and soft cut
 - Extra large chip chambers for an extreme chip volume
- For process reliable, helical diving and immersion
 - For roughing and finishing, up to 2xD full slot
- With central inner cooling

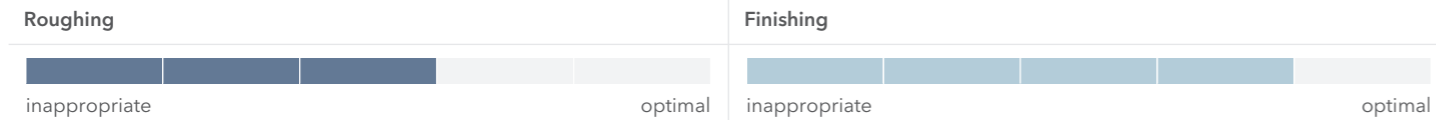
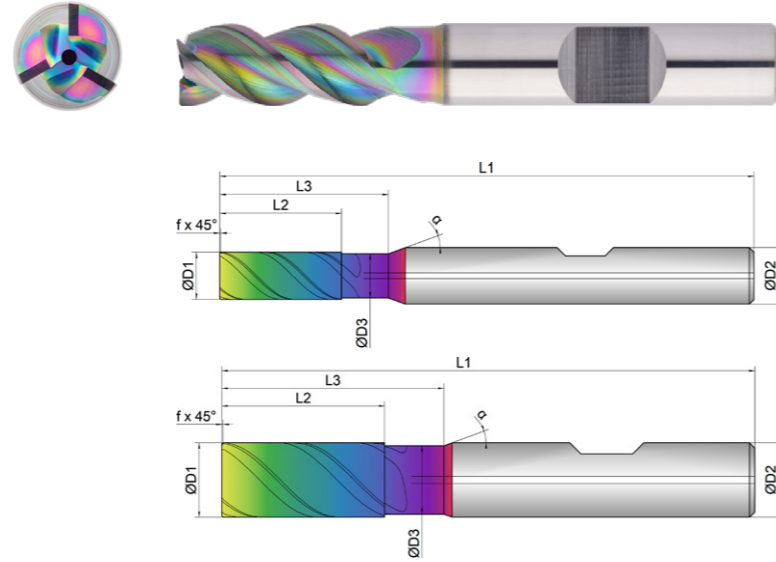

EXN1-M01-0204	D1	D3	L2	L3	L1	D2	z	45°	°	α
	mm	mm	mm	mm	mm	mm	#	mm	°	°
5	5.0	4.7	13.0	18.0	57.0	6.0	3	0.10	45	20
6	6.0	5.7	13.0	18.0	57.0	6.0	3	0.20	45	20
8	8.0	7.4	21.0	25.0	63.0	8.0	3	0.20	45	20
10	10.0	9.2	22.0	30.0	72.0	10.0	3	0.20	45	20
12	12.0	11.0	26.0	36.0	83.0	12.0	3	0.20	45	20
16	16.0	15.0	36.0	42.0	92.0	16.0	3	0.20	45	20
20	20.0	19.0	41.0	52.0	104.0	20.0	3	0.20	45	20



Download Catalog Pages (PDF)

Dimension	Ø5		Ø6		Ø8		Ø10		Ø12		Ø16	
Infeed in mm	ae=1xD	ae=0.3xD	ae=1xD	ae=0.3xD	ae=1xD	ae=0.3xD	ae=1xD	ae=0.3xD	ae=1xD	ae=0.3xD	ae=1xD	ae=0.3xD
Application												

N	Material	Strength (N/mm²)	Feed (mm/Z)	Feed (mm/Z)													
				fz	fz	fz	fz	fz	fz	fz	fz	fz	fz	fz	fz	fz	fz
NON-FERROUS																	
1.1	ALUMINIUM alloyed	<500	500	0.055	0.07	0.06	0.08	0.08	0.1	0.09	0.12	0.1	0.14	0.14	0.18		
1.2	ALUMINIUM alloyed	<600	480	0.055	0.07	0.06	0.08	0.08	0.1	0.09	0.12	0.1	0.14	0.14	0.18		
2.1-2.3	ALUMINIUM casted	<600	450	0.05	0.065	0.055	0.075	0.075	0.09	0.08	0.11	0.09	0.13	0.13	0.17		
3.1-3.3	COPPER alloyed	<650	200	0.045	0.06	0.05	0.07	0.07	0.085	0.075	0.1	0.085	0.12	0.12	0.16		
4.1	MAGNESIUM alloyed	<250	500	0.055	0.07	0.06	0.08	0.08	0.1	0.09	0.12	0.1	0.14	0.14	0.18		
5.1	PLASTICS Thermoplastic	<100	400	0.04	0.05	0.045	0.065	0.055	0.065	0.065	0.085	0.075	0.11	0.11	0.13		
5.2	PLASTICS Duroplastic	<150	350	0.035	0.04	0.035	0.055	0.045	0.055	0.055	0.075	0.065	0.1	0.1	0.12		

Dimension	Ø20	
Infeed in mm	ae=1xD	ae=0.3xD
Application	ap=1xD	ap=2xD

N	Material	Strength (N/mm²)	Feed (mm/Z)	Feed (mm/Z)	
				fz	fz
NON-FERROUS					
1.1	ALUMINIUM alloyed	<500	500	0.18	0.22
1.2	ALUMINIUM alloyed	<600	480	0.18	0.22
2.1-2.3	ALUMINIUM casted	<600	450	0.17	0.2
3.1-3.3	COPPER alloyed	<650	200	0.16	0.18
4.1	MAGNESIUM alloyed	<250	500	0.18	0.22
5.1	PLASTICS Thermoplastic	<100	400	0.13	0.17
5.2	PLASTICS Duroplastic	<150	350	0.12	0.16

Cooling	
Tolerance	h6
Coating	AlphaSlide Rainbow

Strategy	ETC	HPC	
Application			
Features	HA	\neq	

- Defined clearance angle for ideal stabilization with high cutting depths
 - Special helical pitch for smooth running and soft cut
 - Extra large chip chambers for an extreme chip volume
- For process reliable, helical diving and immersion
 - For roughing and finishing
- With central inner cooling
 - Long version for deeper cavities

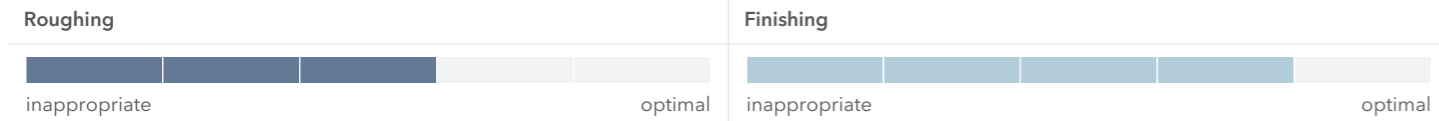
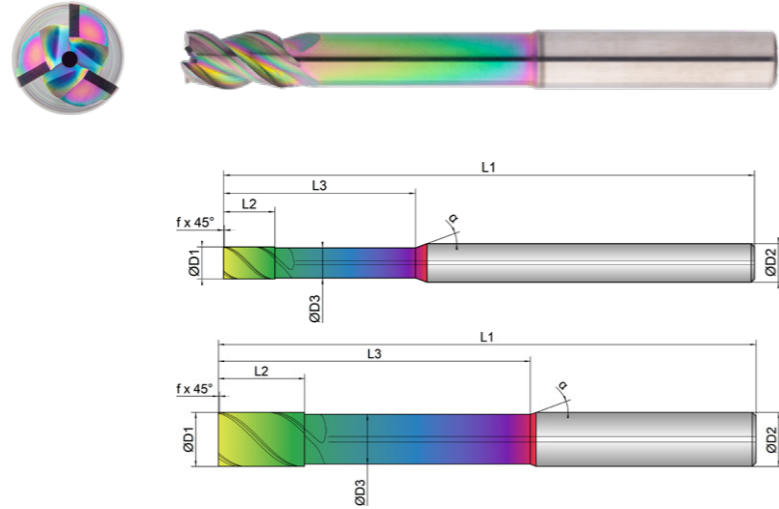

EXN1-M01-0213	D1	D3	L2	L3	L1	D2	z	α	α
	mm \varnothing	mm \varnothing	mm	mm	mm	mm \varnothing	#	mm	$^\circ$
5	5.0	4.7	8.0	30.0	83.0	6.0	3	0.10	45
6	6.0	5.7	10.0	42.0	83.0	6.0	3	0.20	45
8	8.0	7.4	13.0	62.0	100.0	8.0	3	0.20	45
10	10.0	9.2	16.0	58.0	100.0	10.0	3	0.20	45
12	12.0	11.0	19.0	73.0	119.0	12.0	3	0.20	45
16	16.0	15.0	25.0	100.0	150.0	16.0	3	0.20	45
20	20.0	19.0	32.0	98.0	150.0	20.0	3	0.20	45



Download Catalog Pages (PDF)

Dimension	Ø5		Ø6		Ø8		Ø10		Ø12		Ø16	
Infeed in mm	ae=1xD	ae=0.3xD	ae=1xD	ae=0.3xD	ae=1xD	ae=0.3xD	ae=1xD	ae=0.3xD	ae=1xD	ae=0.3xD	ae=1xD	ae=0.3xD
Application												

N	Material	Strength (N/mm ²)	Feed (mm/Z)	fz	fz	fz	fz	fz	fz	fz	fz	fz	fz	fz	
			Vc (m/min)												
1.1	ALUMINIUM alloyed	<500	280	0.05	0.065	0.055	0.065	0.06	0.075	0.075	0.09	0.08	0.1	0.1	0.12
1.2	ALUMINIUM alloyed	<600	260	0.05	0.065	0.055	0.065	0.06	0.075	0.075	0.09	0.08	0.1	0.1	0.12
2.1-2.3	ALUMINIUM casted	<600	240	0.04	0.055	0.045	0.055	0.05	0.065	0.065	0.08	0.07	0.09	0.09	0.11
3.1-3.3	COPPER alloyed	<650	120	0.03	0.045	0.035	0.045	0.04	0.055	0.055	0.07	0.06	0.08	0.08	0.1
4.1	MAGNESIUM alloyed	<250	280	0.05	0.065	0.055	0.065	0.06	0.075	0.075	0.09	0.08	0.1	0.1	0.12
5.1	PLASTICS Thermoplastic	<100	200	0.04	0.055	0.045	0.055	0.05	0.065	0.065	0.08	0.07	0.09	0.09	0.11
5.2	PLASTICS Duroplastic	<150	170	0.03	0.045	0.035	0.045	0.04	0.055	0.055	0.07	0.06	0.08	0.08	0.1

Dimension	Ø20	
Infeed in mm	ae=1xD	ae=0.3xD
Application	ap=1xD	ap=1xD

N	Material	Strength (N/mm ²)	Feed (mm/Z)	fz	fz
			Vc (m/min)		
1.1	ALUMINIUM alloyed	<500	280	0.12	0.14
1.2	ALUMINIUM alloyed	<600	260	0.12	0.14
2.1-2.3	ALUMINIUM casted	<600	240	0.11	0.13
3.1-3.3	COPPER alloyed	<650	120	0.1	0.12
4.1	MAGNESIUM alloyed	<250	280	0.12	0.14
5.1	PLASTICS Thermoplastic	<100	200	0.11	0.13
5.2	PLASTICS Duroplastic	<150	170	0.1	0.12

Cooling

Tolerance h6

Coating AlphaSlide Rainbow

Strategy ETC HPC

Application

Features HB \neq

- Defined clearance angle for ideal stabilization with high cutting depths
 - Special helical pitch for smooth running and soft cut
 - Extra large chip chambers for an extreme chip volume
-
- For process reliable, helical diving and immersion
 - For roughing and finishing
-
- With central inner cooling
 - Long version for deeper cavities

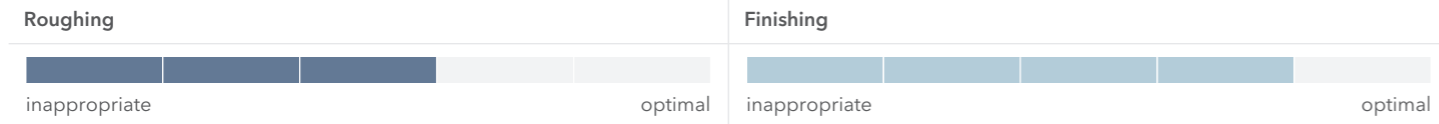
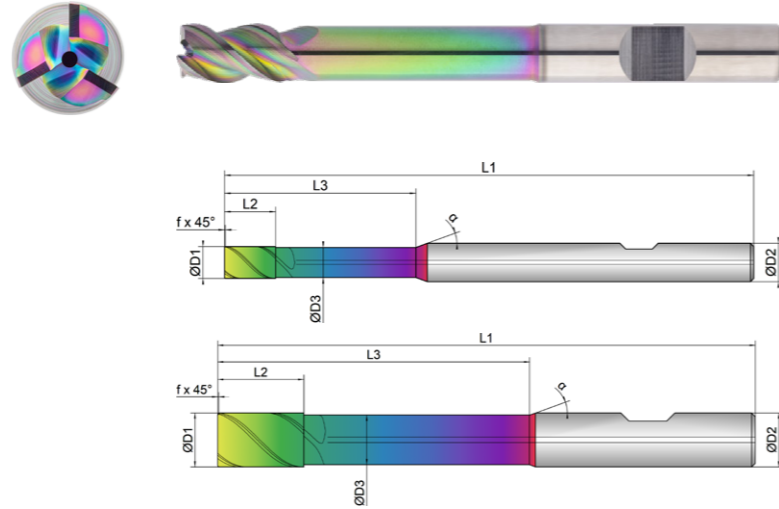

EXN1-M01-0214	D1	D3	L2	L3	L1	D2	z	α	α
	mm \varnothing	mm \varnothing	mm	mm	mm	mm \varnothing	#	mm	$^{\circ}$
5	5.0	4.7	8.0	30.0	83.0	6.0	3	0.10	45
6	6.0	5.7	10.0	42.0	83.0	6.0	3	0.20	45
8	8.0	7.4	13.0	62.0	100.0	8.0	3	0.20	45
10	10.0	9.2	16.0	58.0	100.0	10.0	3	0.20	45
12	12.0	11.0	19.0	73.0	119.0	12.0	3	0.20	45
16	16.0	15.0	25.0	100.0	150.0	16.0	3	0.20	45
20	20.0	19.0	32.0	98.0	150.0	20.0	3	0.20	45



Download Catalog Pages (PDF)

Dimension	$\varnothing 5$		$\varnothing 6$		$\varnothing 8$		$\varnothing 10$		$\varnothing 12$		$\varnothing 16$	
Infeed in mm	ae= 1xD	ae= 0.3xD	ae= 1xD	ae= 0.3xD	ae= 1xD	ae= 0.3xD	ae= 1xD	ae= 0.3xD	ae= 1xD	ae= 0.3xD	ae= 1xD	ae= 0.3xD
Application												

N	Material	Strength (N/mm ²)	Feed (mm/Z)	Feed (mm/Z)											
				fz	fz	fz	fz	fz	fz	fz	fz	fz	fz	fz	fz
	NON-FERROUS		Vc (m/min)												
1.1	ALUMINIUM alloyed	<500	280	0.05	0.065	0.055	0.065	0.06	0.075	0.075	0.09	0.08	0.1	0.1	0.12
1.2	ALUMINIUM alloyed	<600	260	0.05	0.065	0.055	0.065	0.06	0.075	0.075	0.09	0.08	0.1	0.1	0.12
2.1-2.3	ALUMINIUM casted	<600	240	0.04	0.055	0.045	0.055	0.05	0.065	0.065	0.08	0.07	0.09	0.09	0.11
3.1-3.3	COPPER alloyed	<650	120	0.03	0.045	0.035	0.045	0.04	0.055	0.055	0.07	0.06	0.08	0.08	0.1
4.1	MAGNESIUM alloyed	<250	280	0.05	0.065	0.055	0.065	0.06	0.075	0.075	0.09	0.08	0.1	0.1	0.12
5.1	PLASTICS Thermoplastic	<100	200	0.04	0.055	0.045	0.055	0.05	0.065	0.065	0.08	0.07	0.09	0.09	0.11
5.2	PLASTICS Duroplastic	<150	170	0.03	0.045	0.035	0.045	0.04	0.055	0.055	0.07	0.06	0.08	0.08	0.1

Dimension	$\varnothing 20$	
Infeed in mm	ae= 1xD	ae= 0.3xD
Application	ap= 1xD	ap= 1xD

N	Material	Strength (N/mm ²)	Feed (mm/Z)	Feed (mm/Z)	
				fz	fz
	NON-FERROUS		Vc (m/min)		
1.1	ALUMINIUM alloyed	<500	280	0.12	0.14
1.2	ALUMINIUM alloyed	<600	260	0.12	0.14
2.1-2.3	ALUMINIUM casted	<600	240	0.11	0.13
3.1-3.3	COPPER alloyed	<650	120	0.1	0.12
4.1	MAGNESIUM alloyed	<250	280	0.12	0.14
5.1	PLASTICS Thermoplastic	<100	200	0.11	0.13
5.2	PLASTICS Duroplastic	<150	170	0.1	0.12

Cooling	
Tolerance	h6
Coating	AlphaSlide Rainbow

Strategy	ETC	HPC	
Application			
Features	HA	≠	2xD

- Extra large chip chambers for ideal chip evacuation
- Unequal tooth pitch combined with variable helical pitch for smooth running
- Reinforced face with 2 cutting edges to the center
- For process reliable, helical diving and immersion
- For roughing and finishing, up to 1.5xD full slot
- Perfected for high radial depth of cutting and full slot milling

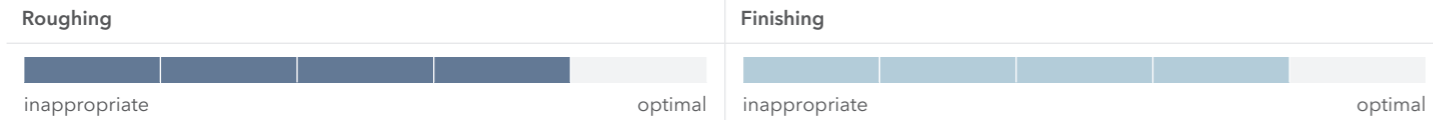
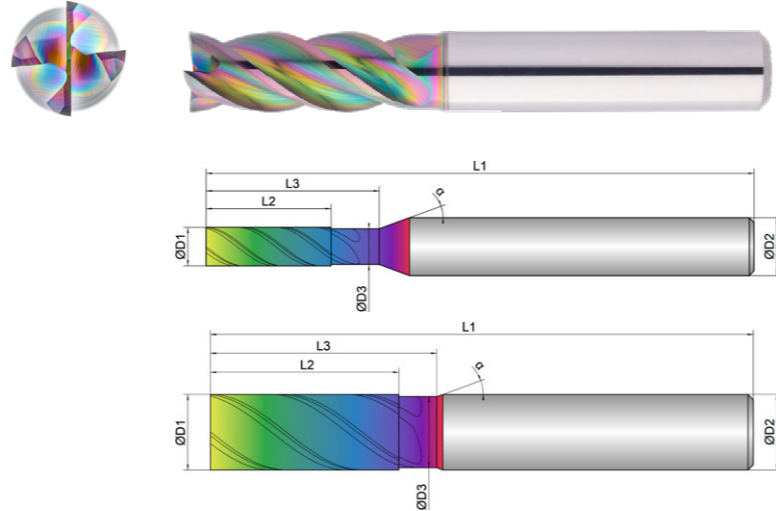

EXN1-M01-0293	D1	D3	L2	L3	L1	D2	z	°	°
	mm	mm	mm	mm	mm	mm	#		
2	2.0	1.8	6.0	13.0	57.0	6.0	4	38	20
3	3.0	2.7	10.0	14.0	57.0	6.0	4	38	20
4	4.0	3.7	13.0	18.0	57.0	6.0	4	38	20
5	5.0	4.5	14.0	18.0	57.0	6.0	4	38	20
6	6.0	5.5	16.0	21.0	57.0	6.0	4	38	20
8	8.0	7.5	22.0	27.0	63.0	8.0	4	38	20
10	10.0	9.4	25.0	30.0	72.0	10.0	4	38	20
12	12.0	11.4	28.0	33.0	83.0	12.0	4	38	20
16	16.0	15.4	36.0	41.0	92.0	16.0	4	38	20
20	20.0	19.4	41.0	51.0	104.0	20.0	4	38	20



Download Catalog Pages (PDF)

Dimension	Ø2		Ø3		Ø4		Ø5		Ø6		Ø8	
Infeed in mm	ae=1xD	ae=0.3xD	ae=1xD	ae=0.3xD	ae=1xD	ae=0.3xD	ae=1xD	ae=0.3xD	ae=1xD	ae=0.3xD	ae=1xD	ae=0.3xD
Application												

N	Material	Strength (N/mm²)	Feed (mm/Z)	Vc (m/min)											
				fz	fz	fz	fz	fz	fz	fz	fz	fz	fz	fz	fz
1.1	ALUMINIUM alloyed	<500	500	0.02	0.03	0.03	0.04	0.04	0.05	0.045	0.065	0.05	0.07	0.07	0.09
1.2	ALUMINIUM alloyed	<600	480	0.02	0.03	0.03	0.04	0.04	0.05	0.045	0.065	0.05	0.07	0.07	0.09
2.1-2.3	ALUMINIUM casted	<600	450	0.015	0.025	0.025	0.035	0.035	0.045	0.04	0.06	0.045	0.065	0.065	0.085
3.1-3.3	COPPER alloyed	<650	200	0.012	0.02	0.02	0.03	0.03	0.04	0.035	0.055	0.035	0.055	0.055	0.075
4.1	MAGNESIUM alloyed	<250	500	0.02	0.03	0.03	0.04	0.04	0.05	0.045	0.065	0.05	0.07	0.07	0.09
5.1	PLASTICS Thermoplastic	<100	400	0.012	0.02	0.02	0.03	0.035	0.045	0.035	0.045	0.04	0.05	0.05	0.07
5.2	PLASTICS Duroplastic	<150	350	0.01	0.015	0.015	0.025	0.03	0.04	0.03	0.04	0.035	0.04	0.04	0.06

Dimension	Ø10		Ø12		Ø16		Ø20	
Infeed in mm	ae=1xD	ae=0.3xD	ae=1xD	ae=0.3xD	ae=1xD	ae=0.3xD	ae=1xD	ae=0.3xD
Application								

N	Material	Strength (N/mm²)	Feed (mm/Z)	Vc (m/min)							
				fz	fz	fz	fz	fz	fz	fz	fz
1.1	ALUMINIUM alloyed	<500	500	0.09	0.11	0.1	0.14	0.12	0.16	0.15	0.2
1.2	ALUMINIUM alloyed	<600	480	0.09	0.11	0.1	0.14	0.12	0.16	0.15	0.2
2.1-2.3	ALUMINIUM casted	<600	450	0.08	0.1	0.09	0.13	0.11	0.15	0.14	0.18
3.1-3.3	COPPER alloyed	<650	200	0.07	0.09	0.08	0.12	0.1	0.13	0.12	0.16
4.1	MAGNESIUM alloyed	<250	500	0.09	0.11	0.1	0.14	0.12	0.16	0.15	0.2
5.1	PLASTICS Thermoplastic	<100	400	0.07	0.09	0.09	0.11	0.1	0.13	0.13	0.17
5.2	PLASTICS Duroplastic	<150	350	0.06	0.08	0.08	0.1	0.09	0.12	0.12	0.16

Cooling

Tolerance h6

Coating AlphaSlide Rainbow

Strategy ETC HPC

Application

Features HB ≠ 2xD



Download Catalog Pages (PDF)

- Extra large chip chambers for ideal chip evacuation
 - Unequal tooth pitch combined with variable helical pitch for smooth running
 - Reinforced face with 2 cutting edges to the center
- For process reliable, helical diving and immersion
 - For roughing and finishing, up to 1.5xD full slot
- Perfected for high radial depth of cutting and full slot milling

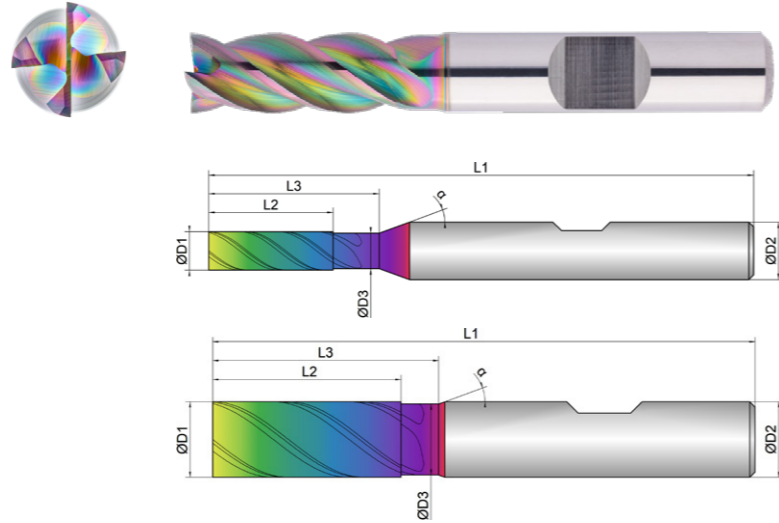

Roughing

Finishing

EXN1-M01-0294	D1 mm Ø	D3 mm Ø	L2 mm	L3 mm	L1 mm	D2 mm Ø	z #		α °
2	2.0	1.8	6.0	13.0	57.0	6.0	4	38	20
3	3.0	2.7	10.0	14.0	57.0	6.0	4	38	20
4	4.0	3.7	13.0	18.0	57.0	6.0	4	38	20
5	5.0	4.5	14.0	18.0	57.0	6.0	4	38	20
6	6.0	5.5	16.0	21.0	57.0	6.0	4	38	20
8	8.0	7.5	22.0	27.0	63.0	8.0	4	38	20
10	10.0	9.4	25.0	30.0	72.0	10.0	4	38	20
12	12.0	11.4	28.0	33.0	83.0	12.0	4	38	20
16	16.0	15.4	36.0	41.0	92.0	16.0	4	38	20
20	20.0	19.4	41.0	51.0	104.0	20.0	4	38	20

Dimension	Ø2		Ø3		Ø4		Ø5		Ø6		Ø8	
Infeed in mm	ae=1xD	ae=0.3xD	ae=1xD	ae=0.3xD	ae=1xD	ae=0.3xD	ae=1xD	ae=0.3xD	ae=1xD	ae=0.3xD	ae=1xD	ae=0.3xD
Application												

N	Material	Strength (N/mm ²)	Feed (mm/Z)	fz	fz	fz	fz	fz	fz	fz	fz	fz	fz	fz	
				Vc (m/min)											
1.1	ALUMINIUM alloyed	<500	500	0.02	0.03	0.03	0.04	0.04	0.05	0.045	0.065	0.05	0.07	0.07	0.09
1.2	ALUMINIUM alloyed	<600	480	0.02	0.03	0.03	0.04	0.04	0.05	0.045	0.065	0.05	0.07	0.07	0.09
2.1-2.3	ALUMINIUM casted	<600	450	0.015	0.025	0.025	0.035	0.035	0.045	0.04	0.06	0.045	0.065	0.065	0.085
3.1-3.3	COPPER alloyed	<650	200	0.012	0.02	0.02	0.03	0.03	0.04	0.035	0.055	0.035	0.055	0.055	0.075
4.1	MAGNESIUM alloyed	<250	500	0.02	0.03	0.03	0.04	0.04	0.05	0.045	0.065	0.05	0.07	0.07	0.09
5.1	PLASTICS Thermoplastic	<100	400	0.012	0.02	0.02	0.03	0.035	0.045	0.035	0.045	0.04	0.05	0.05	0.07
5.2	PLASTICS Duroplastic	<150	350	0.01	0.015	0.015	0.025	0.03	0.04	0.03	0.04	0.035	0.04	0.04	0.06

Dimension	Ø10		Ø12		Ø16		Ø20	
Infeed in mm	ae=1xD	ae=0.3xD	ae=1xD	ae=0.3xD	ae=1xD	ae=0.3xD	ae=1xD	ae=0.3xD
Application								

N	Material	Strength (N/mm ²)	Feed (mm/Z)	fz	fz	fz	fz	fz	fz	fz	fz
				Vc (m/min)							
1.1	ALUMINIUM alloyed	<500	500	0.09	0.11	0.1	0.14	0.12	0.16	0.15	0.2
1.2	ALUMINIUM alloyed	<600	480	0.09	0.11	0.1	0.14	0.12	0.16	0.15	0.2
2.1-2.3	ALUMINIUM casted	<600	450	0.08	0.1	0.09	0.13	0.11	0.15	0.14	0.18
3.1-3.3	COPPER alloyed	<650	200	0.07	0.09	0.08	0.12	0.1	0.13	0.12	0.16
4.1	MAGNESIUM alloyed	<250	500	0.09	0.11	0.1	0.14	0.12	0.16	0.15	0.2
5.1	PLASTICS Thermoplastic	<100	400	0.07	0.09	0.09	0.11	0.1	0.13	0.13	0.17
5.2	PLASTICS Duroplastic	<150	350	0.06	0.08	0.08	0.1	0.09	0.12	0.12	0.16

Cooling	
Tolerance	e8
Coating	AlphaSlide Rainbow

Strategy	ETC	HPC	
Application			
Features	HA	≠	2xD

- Roughing teeth for the smallest chips in volume machining
 - Special helical pitch for smooth running and soft cut
 - Extra large chip chambers for an extreme chip volume
- For roughing, up to 2xD full slot
 - For process reliable, helical diving and immersion
- Also ideally designed for trochoidal milling

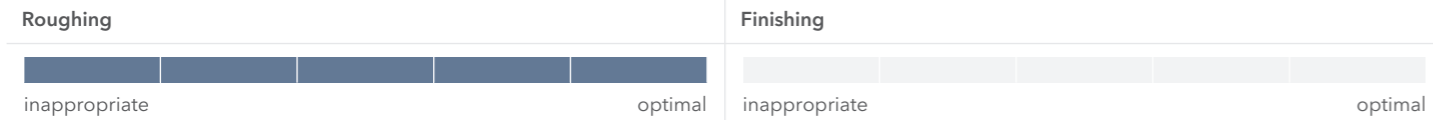
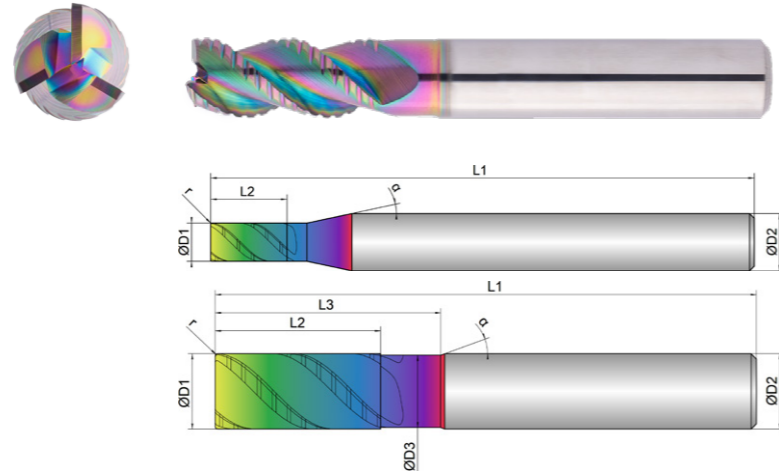

EXN1-M02-0023	D1	D3	L2	L3	L1	D2	z	r		α
	mm ∅	mm ∅	mm	mm	mm	mm ∅	#	mm	°	°
4	4.0	0.0	8.0	0.0	57.0	6.0	3	0.10	45	12
5	5.0	0.0	9.0	0.0	57.0	6.0	3	0.20	45	12
6	6.0	5.6	13.0	19.0	57.0	6.0	3	0.20	45	20
8	8.0	7.6	19.0	25.0	63.0	8.0	3	0.20	45	20
10	10.0	9.6	22.0	30.0	72.0	10.0	3	0.32	45	20
12	12.0	11.4	26.0	36.0	83.0	12.0	3	0.32	45	20
16	16.0	15.4	31.0	42.0	92.0	16.0	3	0.32	45	20
20	20.0	19.4	41.0	52.0	104.0	20.0	3	0.50	45	20



Download Catalog Pages (PDF)

Dimension	Ø4		Ø5		Ø6		Ø8		Ø10		Ø12	
Infeed in mm	ae=1xD	ae=0.6xD	ae=1xD	ae=0.6xD	ae=1xD	ae=0.6xD	ae=1xD	ae=0.6xD	ae=1xD	ae=0.6xD	ae=1xD	ae=0.6xD
Application												

N	Material	Strength (N/mm ²)	Feed (mm/Z)	Feed (mm/Z)													
				fz	fz	fz	fz	fz	fz	fz	fz	fz	fz	fz	fz	fz	fz
NON-FERROUS																	
				Vc (m/min)													
1.1	ALUMINIUM alloyed	<500	500	0.035	0.05	0.05	0.07	0.07	0.09	0.09	0.11	0.11	0.13	0.13	0.15		
1.2	ALUMINIUM alloyed	<600	480	0.035	0.05	0.05	0.07	0.07	0.09	0.09	0.11	0.11	0.13	0.13	0.15		
2.1-2.3	ALUMINIUM casted	<600	450	0.03	0.045	0.045	0.065	0.065	0.085	0.085	0.1	0.1	0.12	0.12	0.14		
3.1-3.3	COPPER alloyed	<650	200	0.025	0.04	0.04	0.06	0.06	0.08	0.08	0.095	0.09	0.11	0.11	0.13		
4.1	MAGNESIUM alloyed	<250	500	0.035	0.05	0.05	0.07	0.07	0.09	0.09	0.11	0.11	0.13	0.13	0.15		
5.1	PLASTICS Thermoplastic	<100	350	0.03	0.045	0.035	0.05	0.05	0.07	0.06	0.07	0.07	0.09	0.07	0.11		
5.2	PLASTICS Duroplastic	<150	300	0.025	0.04	0.03	0.045	0.045	0.06	0.05	0.06	0.06	0.08	0.06	0.1		

Dimension	Ø16		Ø20	
Infeed in mm	ae=1xD	ae=0.6xD	ae=1xD	ae=0.6xD
Application				

N	Material	Strength (N/mm ²)	Feed (mm/Z)	Feed (mm/Z)			
				fz	fz	fz	fz
NON-FERROUS							
			Vc (m/min)				
1.1	ALUMINIUM alloyed	<500	500	0.14	0.16	0.18	0.22
1.2	ALUMINIUM alloyed	<600	480	0.14	0.16	0.18	0.22
2.1-2.3	ALUMINIUM casted	<600	450	0.13	0.15	0.16	0.2
3.1-3.3	COPPER alloyed	<650	200	0.12	0.14	0.14	0.18
4.1	MAGNESIUM alloyed	<250	500	0.14	0.16	0.18	0.22
5.1	PLASTICS Thermoplastic	<100	350	0.11	0.14	0.14	0.18
5.2	PLASTICS Duroplastic	<150	300	0.1	0.13	0.13	0.17

NOTE | The values marked in turquoise are side applications!

Cooling

Tolerance e8

Coating AlphaSlide Rainbow

Strategy **ETC** **HPC**

Application

Features

- Roughing teeth for the smallest chips in volume machining
 - Special helical pitch for smooth running and soft cut
 - Extra large chip chambers for an extreme chip volume
- For roughing, up to 2xD full slot
 - For process reliable, helical diving and immersion
- Also ideally designed for trochoidal milling

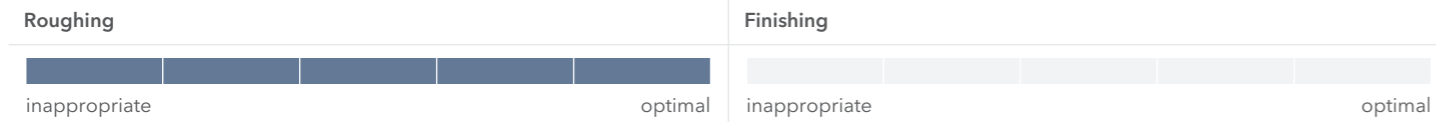
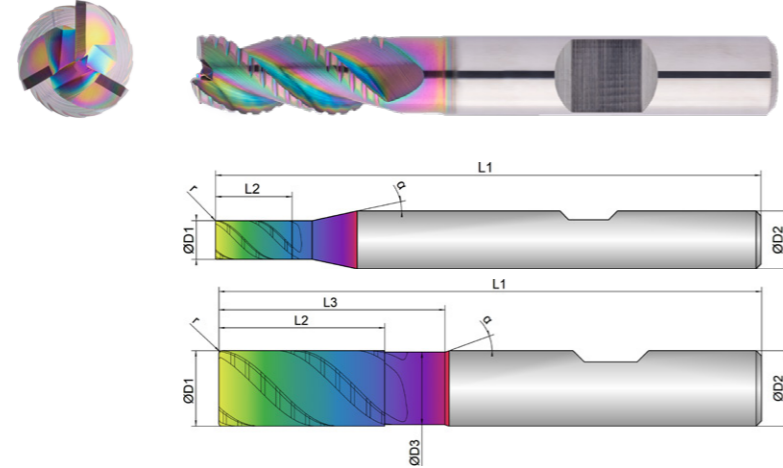

EXN1-M02-0024	D1	D3	L2	L3	L1	D2	z	r		α
	mm \varnothing	mm \varnothing	mm	mm	mm	mm \varnothing	#	mm	R	$^\circ$
4	4.0	0.0	8.0	0.0	57.0	6.0	3	0.10	45	12
5	5.0	0.0	9.0	0.0	57.0	6.0	3	0.20	45	12
6	6.0	5.6	13.0	19.0	57.0	6.0	3	0.20	45	20
8	8.0	7.6	19.0	25.0	63.0	8.0	3	0.20	45	20
10	10.0	9.6	22.0	30.0	72.0	10.0	3	0.32	45	20
12	12.0	11.4	26.0	36.0	83.0	12.0	3	0.32	45	20
16	16.0	15.4	31.0	42.0	92.0	16.0	3	0.32	45	20
20	20.0	19.4	41.0	52.0	104.0	20.0	3	0.50	45	20



Download Catalog Pages (PDF)

Dimension	Ø4		Ø5		Ø6		Ø8		Ø10		Ø12	
Infeed in mm	ae= 1xD	ae= 0.6xD	ae= 1xD	ae= 0.6xD	ae= 1xD	ae= 0.6xD	ae= 1xD	ae= 0.6xD	ae= 1xD	ae= 0.6xD	ae= 1xD	ae= 0.6xD
Application	ap= 2xD	ap= 2xD	ap= 2xD	ap= 2xD	ap= 2xD	ap= 2xD	ap= 2xD	ap= 2xD	ap= 2xD	ap= 2xD	ap= 2xD	ap= 2xD

N	Material	Strength (N/mm ²)	Feed (mm/Z)	Feed (mm/Z)											
				fz	fz	fz	fz	fz	fz	fz	fz	fz	fz	fz	fz
NON-FERROUS													Vc (m/min)		
1.1	ALUMINIUM alloyed	<500	500	0.035	0.05	0.05	0.07	0.07	0.09	0.09	0.11	0.11	0.13	0.13	0.15
1.2	ALUMINIUM alloyed	<600	480	0.035	0.05	0.05	0.07	0.07	0.09	0.09	0.11	0.11	0.13	0.13	0.15
2.1-2.3	ALUMINIUM casted	<600	450	0.03	0.045	0.045	0.065	0.065	0.085	0.085	0.1	0.1	0.12	0.12	0.14
3.1-3.3	COPPER alloyed	<650	200	0.025	0.04	0.04	0.06	0.06	0.08	0.08	0.095	0.09	0.11	0.11	0.13
4.1	MAGNESIUM alloyed	<250	500	0.035	0.05	0.05	0.07	0.07	0.09	0.09	0.11	0.11	0.13	0.13	0.15
5.1	PLASTICS Thermoplastic	<100	350	0.03	0.045	0.035	0.05	0.05	0.07	0.06	0.07	0.07	0.09	0.07	0.11
5.2	PLASTICS Duroplastic	<150	300	0.025	0.04	0.03	0.045	0.045	0.06	0.05	0.06	0.06	0.08	0.06	0.1

Dimension	Ø16		Ø20	
Infeed in mm	ae= 1xD	ae= 0.6xD	ae= 1xD	ae= 0.6xD
Application	ap= 2xD	ap= 2xD	ap= 2xD	ap= 2xD

N	Material	Strength (N/mm ²)	Feed (mm/Z)	Feed (mm/Z)			
				fz	fz	fz	fz
NON-FERROUS							Vc (m/min)
1.1	ALUMINIUM alloyed	<500	500	0.14	0.16	0.18	0.22
1.2	ALUMINIUM alloyed	<600	480	0.14	0.16	0.18	0.22
2.1-2.3	ALUMINIUM casted	<600	450	0.13	0.15	0.16	0.2
3.1-3.3	COPPER alloyed	<650	200	0.12	0.14	0.14	0.18
4.1	MAGNESIUM alloyed	<250	500	0.14	0.16	0.18	0.22
5.1	PLASTICS Thermoplastic	<100	350	0.11	0.14	0.14	0.18
5.2	PLASTICS Duroplastic	<150	300	0.1	0.13	0.13	0.17

NOTE | The values marked in turquoise are side applications!

Cooling	
Tolerance	e8
Coating	AlphaSlide Rainbow

Strategy	ETC	HPC	
Application			
Features	HA	≠	3xD

- Roughing teeth for the smallest chips in volume machining
 - Special helical pitch for smooth running and soft cut
 - Extra large chip chambers for an extreme chip volume
- For roughing, up to 3xD full slot
 - For process reliable, helical diving and immersion
- Also ideally designed for trochoidal milling

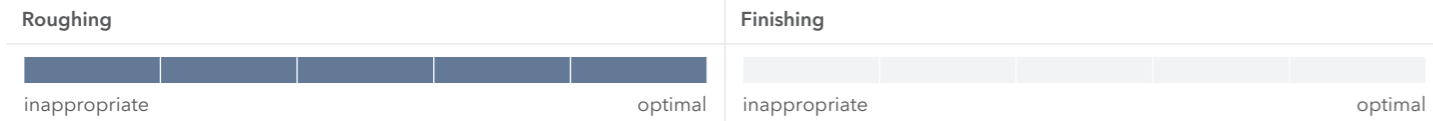
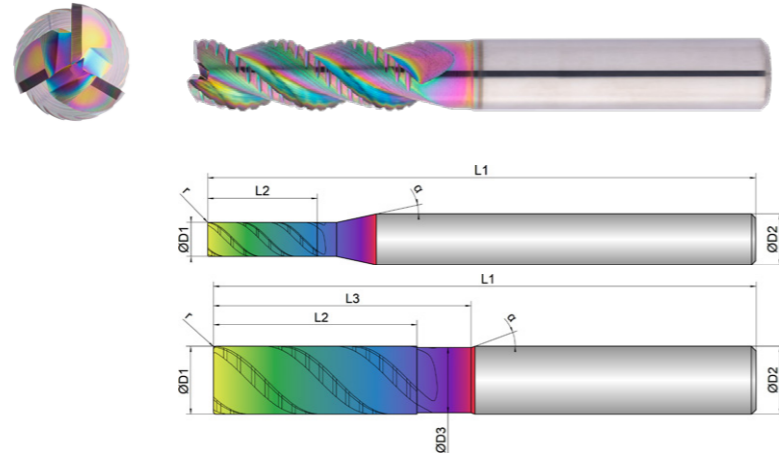

EXN1-M02-0053	D1	D3	L2	L3	L1	D2	z	r	α
	mm Ø	mm Ø	mm	mm	mm	mm Ø	#	mm	°
4	4.0	0.0	13.0	0.0	65.0	6.0	3	0.10	45
5	5.0	0.0	16.0	0.0	65.0	6.0	3	0.20	45
6	6.0	5.6	18.0	24.0	65.0	6.0	3	0.20	45
8	8.0	7.6	24.0	30.0	70.0	8.0	3	0.20	45
10	10.0	9.6	30.0	38.0	80.0	10.0	3	0.32	45
12	12.0	11.4	36.0	46.0	93.0	12.0	3	0.32	45
16	16.0	15.4	48.0	58.0	110.0	16.0	3	0.32	45
20	20.0	19.4	60.0	74.0	125.0	20.0	3	0.50	45



Download Catalog Pages (PDF)

Dimension	Ø4		Ø5		Ø6		Ø8		Ø10		Ø12	
Infeed in mm	ae=1xD	ae=0.3xD	ae=1xD	ae=0.3xD	ae=1xD	ae=0.3xD	ae=1xD	ae=0.3xD	ae=1xD	ae=0.3xD	ae=1xD	ae=0.3xD
Application												

N	Material	Strength (N/mm ²)	Feed (mm/Z)	Feed (mm/Z)											
				fz	fz	fz	fz	fz	fz	fz	fz	fz	fz	fz	fz
NON-FERROUS															
1.1	ALUMINIUM alloyed	<500	500	0.03	0.04	0.04	0.06	0.06	0.08	0.08	0.1	0.1	0.12	0.12	0.14
1.2	ALUMINIUM alloyed	<600	480	0.03	0.04	0.04	0.06	0.06	0.08	0.08	0.1	0.1	0.12	0.12	0.14
2.1-2.3	ALUMINIUM casted	<600	450	0.025	0.035	0.035	0.055	0.055	0.07	0.07	0.09	0.09	0.11	0.11	0.13
3.1-3.3	COPPER alloyed	<650	200	0.015	0.025	0.025	0.045	0.045	0.06	0.06	0.08	0.08	0.1	0.1	0.12
4.1	MAGNESIUM alloyed	<250	500	0.03	0.04	0.04	0.06	0.06	0.08	0.08	0.1	0.1	0.12	0.12	0.14
5.1	PLASTICS Thermoplastic	<100	350	0.025	0.035	0.03	0.045	0.04	0.06	0.05	0.06	0.06	0.08	0.06	0.1
5.2	PLASTICS Duroplastic	<150	300	0.02	0.03	0.025	0.04	0.035	0.055	0.04	0.05	0.05	0.07	0.05	0.09

Dimension	Ø16		Ø20	
Infeed in mm	ae=1xD	ae=0.3xD	ae=1xD	ae=0.3xD
Application				

N	Material	Strength (N/mm ²)	Feed (mm/Z)	Feed (mm/Z)			
				fz	fz	fz	fz
NON-FERROUS							
1.1	ALUMINIUM alloyed	<500	500	0.13	0.15	0.16	0.2
1.2	ALUMINIUM alloyed	<600	480	0.13	0.15	0.16	0.2
2.1-2.3	ALUMINIUM casted	<600	450	0.12	0.14	0.14	0.18
3.1-3.3	COPPER alloyed	<650	200	0.11	0.13	0.13	0.16
4.1	MAGNESIUM alloyed	<250	500	0.13	0.15	0.16	0.2
5.1	PLASTICS Thermoplastic	<100	350	0.1	0.13	0.13	0.17
5.2	PLASTICS Duroplastic	<150	300	0.09	0.12	0.12	0.16

NOTE | The values marked in turquoise are side applications!

Cooling

Tolerance e8

Coating AlphaSlide Rainbow

Strategy ETC HPC

Application

Features HB ≠ 3xD



Download Catalog Pages (PDF)

- Roughing teeth for the smallest chips in volume machining
 - Special helical pitch for smooth running and soft cut
 - Extra large chip chambers for an extreme chip volume
- For roughing, up to 3xD full slot
 - For process reliable, helical diving and immersion
- Also ideally designed for trochoidal milling

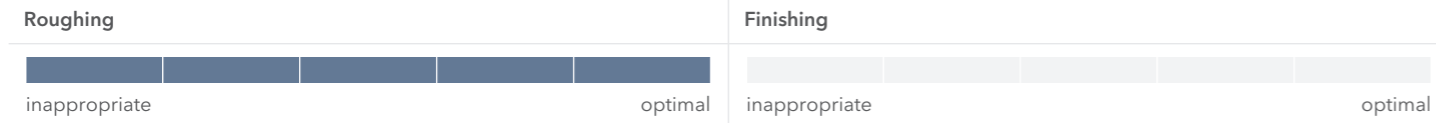
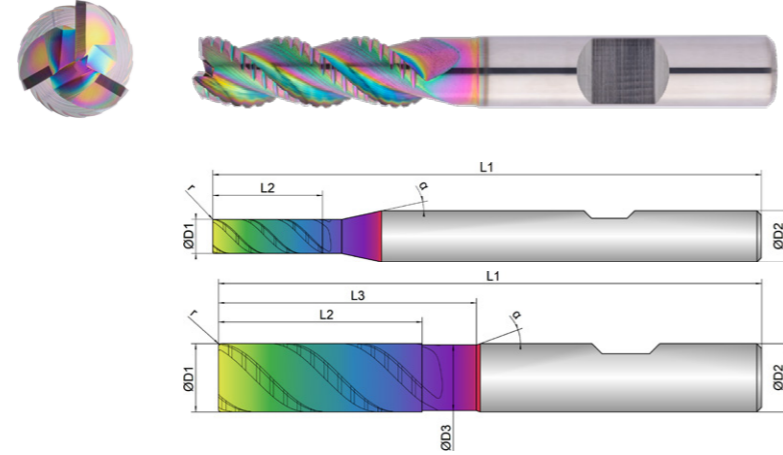

EXN1-M02-0054	D1	D3	L2	L3	L1	D2	z	r	α
	mm Ø	mm Ø	mm	mm	mm	mm Ø	#	mm	°
4	4.0	0.0	13.0	0.0	65.0	6.0	3	0.10	45
5	5.0	0.0	16.0	0.0	65.0	6.0	3	0.20	45
6	6.0	5.6	18.0	24.0	65.0	6.0	3	0.20	45
8	8.0	7.6	24.0	30.0	70.0	8.0	3	0.20	45
10	10.0	9.6	30.0	38.0	80.0	10.0	3	0.32	45
12	12.0	11.4	36.0	46.0	93.0	12.0	3	0.32	45
16	16.0	15.4	48.0	58.0	110.0	16.0	3	0.32	45
20	20.0	19.4	60.0	74.0	125.0	20.0	3	0.50	45

Dimension	Ø4		Ø5		Ø6		Ø8		Ø10		Ø12	
Infeed in mm	ae=1xD	ae=0.3xD	ae=1xD	ae=0.3xD	ae=1xD	ae=0.3xD	ae=1xD	ae=0.3xD	ae=1xD	ae=0.3xD	ae=1xD	ae=0.3xD
Application												

N	Material	Strength (N/mm ²)	Feed (mm/Z)	Feed (mm/Z)											
				fz	fz	fz	fz	fz	fz	fz	fz	fz	fz	fz	fz
NON-FERROUS															
			Vc (m/min)												
1.1	ALUMINIUM alloyed	<500	500	0.03	0.04	0.04	0.06	0.06	0.08	0.08	0.1	0.1	0.12	0.12	0.14
1.2	ALUMINIUM alloyed	<600	480	0.03	0.04	0.04	0.06	0.06	0.08	0.08	0.1	0.1	0.12	0.12	0.14
2.1-2.3	ALUMINIUM casted	<600	450	0.025	0.035	0.035	0.055	0.055	0.07	0.07	0.09	0.09	0.11	0.11	0.13
3.1-3.3	COPPER alloyed	<650	200	0.015	0.025	0.025	0.045	0.045	0.06	0.06	0.08	0.08	0.1	0.1	0.12
4.1	MAGNESIUM alloyed	<250	500	0.03	0.04	0.04	0.06	0.06	0.08	0.08	0.1	0.1	0.12	0.12	0.14
5.1	PLASTICS Thermoplastic	<100	350	0.025	0.035	0.03	0.045	0.04	0.06	0.05	0.06	0.06	0.08	0.06	0.1
5.2	PLASTICS Duroplastic	<150	300	0.02	0.03	0.025	0.04	0.035	0.055	0.04	0.05	0.05	0.07	0.05	0.09

Dimension	Ø16		Ø20	
Infeed in mm	ae=1xD	ae=0.3xD	ae=1xD	ae=0.3xD
Application				

N	Material	Strength (N/mm ²)	Feed (mm/Z)	Feed (mm/Z)			
				fz	fz	fz	fz
NON-FERROUS							
			Vc (m/min)				
1.1	ALUMINIUM alloyed	<500	500	0.13	0.15	0.16	0.2
1.2	ALUMINIUM alloyed	<600	480	0.13	0.15	0.16	0.2
2.1-2.3	ALUMINIUM casted	<600	450	0.12	0.14	0.14	0.18
3.1-3.3	COPPER alloyed	<650	200	0.11	0.13	0.13	0.16
4.1	MAGNESIUM alloyed	<250	500	0.13	0.15	0.16	0.2
5.1	PLASTICS Thermoplastic	<100	350	0.1	0.13	0.13	0.17
5.2	PLASTICS Duroplastic	<150	300	0.09	0.12	0.12	0.16

NOTE | The values marked in turquoise are side applications!

Cooling	
Tolerance	e8
Coating	AlphaSlide Rainbow

Strategy	ETC	HPC	
Application			
Features	HA	≠	



Download Catalog Pages (PDF)

- Roughing teeth for the smallest chips in volume machining
- Special helical pitch for smooth running and soft cut
- Extra large chip chambers for an extreme chip volume

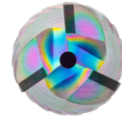

- For roughing, up to 2xD full slot
- For process reliable, helical diving and immersion

- With central inner cooling
- Also ideally designed for trochoidal milling

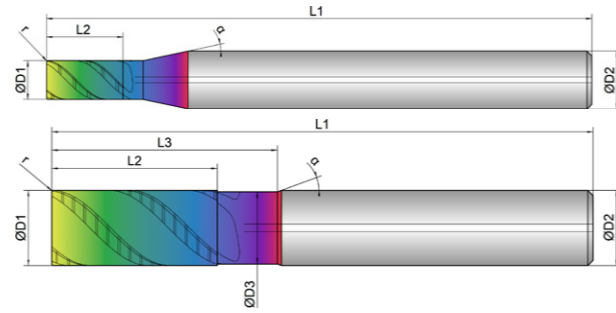

Roughing					Finishing				
inappropriate					optimal				

EXN1-M02-0123	D1	D3	L2	L3	L1	D2	z	r	α
	mm	mm	mm	mm	mm	mm	#	mm	°
4	4.0	0.0	8.0	0.0	57.0	6.0	3	0.10	45
5	5.0	0.0	9.0	0.0	57.0	6.0	3	0.20	45
6	6.0	5.6	13.0	19.0	57.0	6.0	3	0.20	45
8	8.0	7.6	19.0	25.0	63.0	8.0	3	0.20	45
10	10.0	9.6	22.0	30.0	72.0	10.0	3	0.32	45
12	12.0	11.4	26.0	36.0	83.0	12.0	3	0.32	45
16	16.0	15.4	31.0	42.0	92.0	16.0	3	0.32	45
20	20.0	19.4	41.0	52.0	104.0	20.0	3	0.50	45

Dimension	Ø4		Ø5		Ø6		Ø8		Ø10		Ø12	
Infeed in mm	ae=1xD	ae=0.6xD	ae=1xD	ae=0.6xD	ae=1xD	ae=0.6xD	ae=1xD	ae=0.6xD	ae=1xD	ae=0.6xD	ae=1xD	ae=0.6xD
Application												

N	Material	Strength (N/mm ²)	Feed (mm/Z)	Feed (mm/Z)											
				fz	fz	fz	fz	fz	fz	fz	fz	fz	fz	fz	fz
NON-FERROUS															
				Vc (m/min)											
1.1	ALUMINIUM alloyed	<500	500	0.035	0.05	0.05	0.07	0.07	0.09	0.09	0.11	0.11	0.13	0.13	0.15
1.2	ALUMINIUM alloyed	<600	480	0.035	0.05	0.05	0.07	0.07	0.09	0.09	0.11	0.11	0.13	0.13	0.15
2.1-2.3	ALUMINIUM casted	<600	450	0.03	0.045	0.045	0.065	0.065	0.085	0.085	0.1	0.1	0.12	0.12	0.14
3.1-3.3	COPPER alloyed	<650	200	0.025	0.04	0.04	0.06	0.06	0.08	0.08	0.095	0.09	0.11	0.11	0.13
4.1	MAGNESIUM alloyed	<250	500	0.035	0.05	0.05	0.07	0.07	0.09	0.09	0.11	0.11	0.13	0.13	0.15
5.1	PLASTICS Thermoplastic	<100	350	0.03	0.045	0.035	0.05	0.05	0.07	0.06	0.07	0.07	0.09	0.07	0.11
5.2	PLASTICS Duroplastic	<150	300	0.025	0.04	0.03	0.045	0.045	0.06	0.05	0.06	0.06	0.08	0.06	0.1

Dimension	Ø16		Ø20	
Infeed in mm	ae=1xD	ae=0.6xD	ae=1xD	ae=0.6xD
Application				

N	Material	Strength (N/mm ²)	Feed (mm/Z)	Feed (mm/Z)			
				fz	fz	fz	fz
NON-FERROUS							
			Vc (m/min)				
1.1	ALUMINIUM alloyed	<500	500	0.14	0.16	0.18	0.22
1.2	ALUMINIUM alloyed	<600	480	0.14	0.16	0.18	0.22
2.1-2.3	ALUMINIUM casted	<600	450	0.13	0.15	0.16	0.2
3.1-3.3	COPPER alloyed	<650	200	0.12	0.14	0.14	0.18
4.1	MAGNESIUM alloyed	<250	500	0.14	0.16	0.18	0.22
5.1	PLASTICS Thermoplastic	<100	350	0.11	0.14	0.14	0.18
5.2	PLASTICS Duroplastic	<150	300	0.1	0.13	0.13	0.17

NOTE | The values marked in turquoise are side applications!

Cooling	
Tolerance	e8
Coating	AlphaSlide Rainbow

Strategy	ETC HPC	
Application		
Features	HB ≠	



Download Catalog Pages (PDF)

- Roughing teeth for the smallest chips in volume machining
 - Special helical pitch for smooth running and soft cut
 - Extra large chip chambers for an extreme chip volume
- For roughing, up to 2xD full slot
 - For process reliable, helical diving and immersion
- With central inner cooling
 - Also ideally designed for trochoidal milling

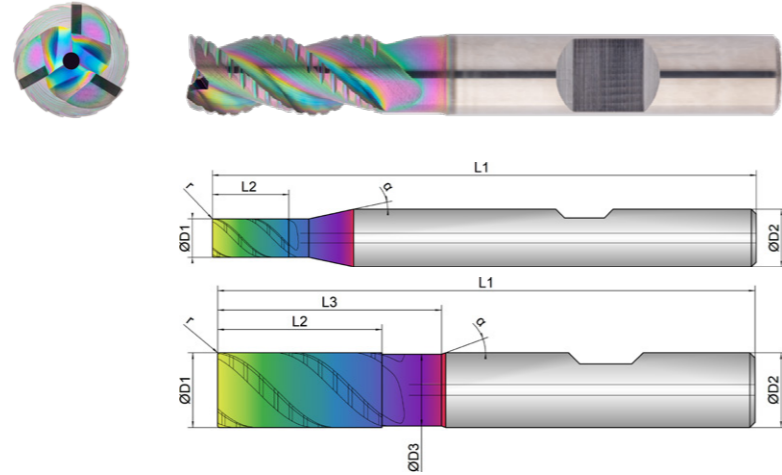

Roughing					Finishing				
inappropriate					optimal				
inappropriate					optimal				

EXN1-M02-0124	D1 mm ø	D3 mm ø	L2 mm	L3 mm	L1 mm	D2 mm ø	z #	r mm	α °
4	4.0	0.0	8.0	0.0	57.0	6.0	3	0.10	45
5	5.0	0.0	9.0	0.0	57.0	6.0	3	0.20	45
6	6.0	5.6	13.0	19.0	57.0	6.0	3	0.20	45
8	8.0	7.6	19.0	25.0	63.0	8.0	3	0.20	45
10	10.0	9.6	22.0	30.0	72.0	10.0	3	0.32	45
12	12.0	11.4	26.0	36.0	83.0	12.0	3	0.32	45
16	16.0	15.4	31.0	42.0	92.0	16.0	3	0.32	45
20	20.0	19.4	41.0	52.0	104.0	20.0	3	0.50	45

Dimension	Ø4		Ø5		Ø6		Ø8		Ø10		Ø12	
Infeed in mm	ae=1xD	ae=0.6xD	ae=1xD	ae=0.6xD	ae=1xD	ae=0.6xD	ae=1xD	ae=0.6xD	ae=1xD	ae=0.6xD	ae=1xD	ae=0.6xD
Application												

N	Material	Strength (N/mm ²)	Feed (mm/Z)	fz											
				Vc (m/min)											
1.1	ALUMINIUM alloyed	<500	500	0.035	0.05	0.05	0.07	0.07	0.09	0.09	0.11	0.11	0.13	0.13	0.15
1.2	ALUMINIUM alloyed	<600	480	0.035	0.05	0.05	0.07	0.07	0.09	0.09	0.11	0.11	0.13	0.13	0.15
2.1-2.3	ALUMINIUM casted	<600	450	0.03	0.045	0.045	0.065	0.065	0.085	0.085	0.1	0.1	0.12	0.12	0.14
3.1-3.3	COPPER alloyed	<650	200	0.025	0.04	0.04	0.06	0.06	0.08	0.08	0.095	0.09	0.11	0.11	0.13
4.1	MAGNESIUM alloyed	<250	500	0.035	0.05	0.05	0.07	0.07	0.09	0.09	0.11	0.11	0.13	0.13	0.15
5.1	PLASTICS Thermoplastic	<100	350	0.03	0.045	0.035	0.05	0.05	0.07	0.06	0.07	0.07	0.09	0.07	0.11
5.2	PLASTICS Duroplastic	<150	300	0.025	0.04	0.03	0.045	0.045	0.06	0.05	0.06	0.06	0.08	0.06	0.1

Dimension	Ø16		Ø20	
Infeed in mm	ae=1xD	ae=0.6xD	ae=1xD	ae=0.6xD
Application				

N	Material	Strength (N/mm ²)	Feed (mm/Z)	fz			
				Vc (m/min)			
1.1	ALUMINIUM alloyed	<500	500	0.14	0.16	0.18	0.22
1.2	ALUMINIUM alloyed	<600	480	0.14	0.16	0.18	0.22
2.1-2.3	ALUMINIUM casted	<600	450	0.13	0.15	0.16	0.2
3.1-3.3	COPPER alloyed	<650	200	0.12	0.14	0.14	0.18
4.1	MAGNESIUM alloyed	<250	500	0.14	0.16	0.18	0.22
5.1	PLASTICS Thermoplastic	<100	350	0.11	0.14	0.14	0.18
5.2	PLASTICS Duroplastic	<150	300	0.1	0.13	0.13	0.17

NOTE | The values marked in turquoise are side applications!

Cooling	
Tolerance	e8
Coating	AlphaSlide Rainbow

Strategy	ETC HPC	
Application		
Features	HA ≠ R 3xD	

- Roughing teeth for the smallest chips in volume machining
 - Special helical pitch for smooth running and soft cut
 - Extra large chip chambers for an extreme chip volume
-
- For roughing, up to 3xD full slot
 - For process reliable, helical diving and immersion
-
- With central inner cooling
 - Also ideally designed for trochoidal milling

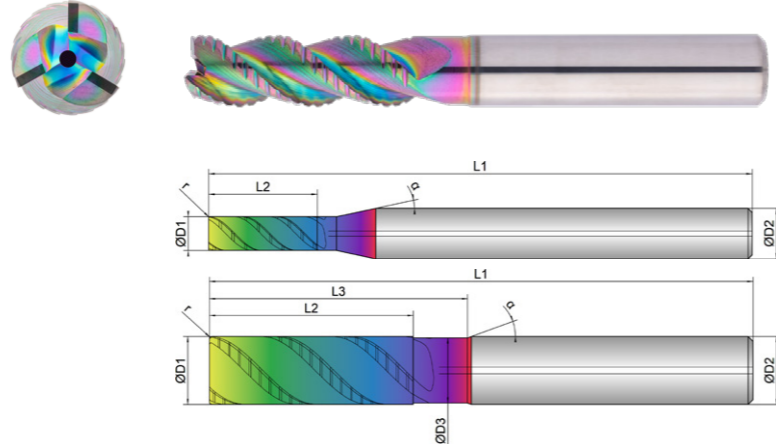

Roughing					Finishing				
inappropriate					optimal				
optimal					inappropriate				
optimal					optimal				

EXN1-M02-0163	D1 mm ∅	D3 mm ∅	L2 mm	L3 mm	L1 mm	D2 mm ∅	z #	r mm		α °
4	4.0	0.0	13.0	0.0	65.0	6.0	3	0.10	45	12
5	5.0	0.0	16.0	0.0	65.0	6.0	3	0.20	45	12
6	6.0	5.6	18.0	24.0	65.0	6.0	3	0.20	45	20
8	8.0	7.6	24.0	30.0	70.0	8.0	3	0.20	45	20
10	10.0	9.6	30.0	38.0	80.0	10.0	3	0.32	45	20
12	12.0	11.4	36.0	46.0	93.0	12.0	3	0.32	45	20
16	16.0	15.4	48.0	58.0	110.0	16.0	3	0.32	45	20
20	20.0	19.4	60.0	74.0	125.0	20.0	3	0.50	45	20



Download Catalog Pages (PDF)

Dimension	Ø4		Ø5		Ø6		Ø8		Ø10		Ø12	
Infeed in mm	ae= 1xD	ae= 0.3xD	ae= 1xD	ae= 0.3xD	ae= 1xD	ae= 0.3xD	ae= 1xD	ae= 0.3xD	ae= 1xD	ae= 0.3xD	ae= 1xD	ae= 0.3xD
Application	ap= 2xD	ap= 3xD	ap= 2xD	ap= 3xD	ap= 2xD	ap= 3xD	ap= 2xD	ap= 3xD	ap= 2xD	ap= 3xD	ap= 2xD	ap= 3xD

N	Material	Strength (N/mm ²)	Feed (mm/Z)	Feed (mm/Z)											
				fz	fz	fz	fz	fz	fz	fz	fz	fz	fz	fz	fz
NON-FERROUS															
			Vc (m/min)												
1.1	ALUMINIUM alloyed	<500	500	0.03	0.04	0.04	0.06	0.06	0.08	0.08	0.1	0.1	0.12	0.12	0.14
1.2	ALUMINIUM alloyed	<600	480	0.03	0.04	0.04	0.06	0.06	0.08	0.08	0.1	0.1	0.12	0.12	0.14
2.1-2.3	ALUMINIUM casted	<600	450	0.025	0.035	0.035	0.055	0.055	0.07	0.07	0.09	0.09	0.11	0.11	0.13
3.1-3.3	COPPER alloyed	<650	200	0.015	0.025	0.025	0.045	0.045	0.06	0.06	0.08	0.08	0.1	0.1	0.12
4.1	MAGNESIUM alloyed	<250	500	0.03	0.04	0.04	0.06	0.06	0.08	0.08	0.1	0.1	0.12	0.12	0.14
5.1	PLASTICS Thermoplastic	<100	350	0.025	0.035	0.03	0.045	0.04	0.06	0.05	0.06	0.06	0.08	0.06	0.1
5.2	PLASTICS Duroplastic	<150	300	0.02	0.03	0.025	0.04	0.035	0.055	0.04	0.05	0.05	0.07	0.05	0.09

Dimension	Ø16		Ø20	
Infeed in mm	ae= 1xD	ae= 0.3xD	ae= 1xD	ae= 0.3xD
Application	ap= 2xD	ap= 3xD	ap= 2xD	ap= 3xD

N	Material	Strength (N/mm ²)	Feed (mm/Z)	Feed (mm/Z)			
				fz	fz	fz	fz
NON-FERROUS							
			Vc (m/min)				
1.1	ALUMINIUM alloyed	<500	500	0.13	0.15	0.16	0.2
1.2	ALUMINIUM alloyed	<600	480	0.13	0.15	0.16	0.2
2.1-2.3	ALUMINIUM casted	<600	450	0.12	0.14	0.14	0.18
3.1-3.3	COPPER alloyed	<650	200	0.11	0.13	0.13	0.16
4.1	MAGNESIUM alloyed	<250	500	0.13	0.15	0.16	0.2
5.1	PLASTICS Thermoplastic	<100	350	0.1	0.13	0.13	0.17
5.2	PLASTICS Duroplastic	<150	300	0.09	0.12	0.12	0.16

NOTE | The values marked in turquoise are side applications!

Cooling

Tolerance e8

Coating AlphaSlide Rainbow

Strategy ETC HPC

Application

Features HB ≠



Download Catalog Pages (PDF)

Dimension	Ø4		Ø5		Ø6		Ø8		Ø10		Ø12	
Infeed in mm	ae= 1xD	ae= 0.3xD	ae= 1xD	ae= 0.3xD	ae= 1xD	ae= 0.3xD	ae= 1xD	ae= 0.3xD	ae= 1xD	ae= 0.3xD	ae= 1xD	ae= 0.3xD
	ap= 2xD	ap= 3xD	ap= 2xD	ap= 3xD	ap= 2xD	ap= 3xD	ap= 2xD	ap= 3xD	ap= 2xD	ap= 3xD	ap= 2xD	ap= 3xD
Application												

- Roughing teeth for the smallest chips in volume machining
- Special helical pitch for smooth running and soft cut
- Extra large chip chambers for an extreme chip volume

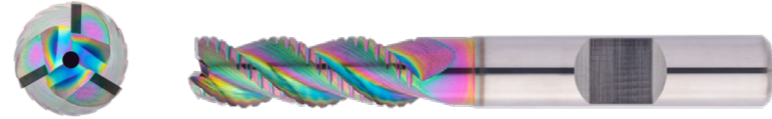

- For roughing, up to 3xD full slot
- For process reliable, helical diving and immersion

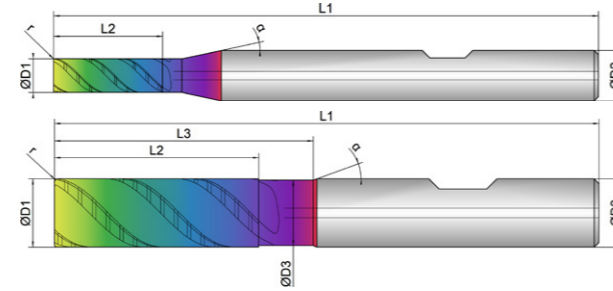

- With central inner cooling
- Also ideally designed for trochoidal milling

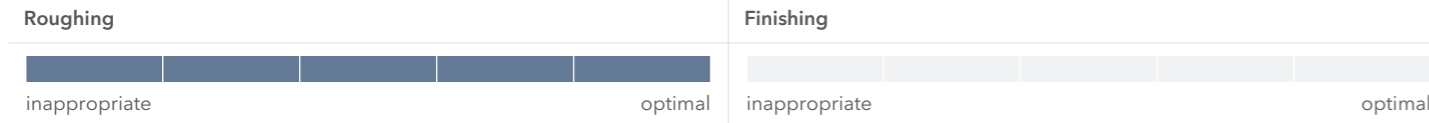

EXN1-M02-0164	D1	D3	L2	L3	L1	D2	z	r		α
	mm Ø	mm Ø	mm	mm	mm	mm Ø	#	mm	°	°
4	4.0	0.0	13.0	0.0	65.0	6.0	3	0.10	45	12
5	5.0	0.0	16.0	0.0	65.0	6.0	3	0.20	45	12
6	6.0	5.6	18.0	24.0	65.0	6.0	3	0.20	45	20
8	8.0	7.6	24.0	30.0	70.0	8.0	3	0.20	45	20
10	10.0	9.6	30.0	38.0	80.0	10.0	3	0.32	45	20
12	12.0	11.4	36.0	46.0	93.0	12.0	3	0.32	45	20
16	16.0	15.4	48.0	58.0	110.0	16.0	3	0.32	45	20
20	20.0	19.4	60.0	74.0	125.0	20.0	3	0.50	45	20

N	Material	Strength (N/mm ²)	Feed (mm/Z)	fz													
				Vc (m/min)													
1.1	ALUMINIUM alloyed	<500	500	0.03	0.04	0.04	0.06	0.06	0.08	0.08	0.1	0.1	0.12	0.12	0.14		
1.2	ALUMINIUM alloyed	<600	480	0.03	0.04	0.04	0.06	0.06	0.08	0.08	0.1	0.1	0.12	0.12	0.14		
2.1-2.3	ALUMINIUM casted	<600	450	0.025	0.035	0.035	0.055	0.055	0.07	0.07	0.09	0.09	0.11	0.11	0.13		
3.1-3.3	COPPER alloyed	<650	200	0.015	0.025	0.025	0.045	0.045	0.06	0.06	0.08	0.08	0.1	0.1	0.12		
4.1	MAGNESIUM alloyed	<250	500	0.03	0.04	0.04	0.06	0.06	0.08	0.08	0.1	0.1	0.12	0.12	0.14		
5.1	PLASTICS Thermoplastic	<100	350	0.025	0.035	0.03	0.045	0.04	0.06	0.05	0.06	0.06	0.08	0.06	0.1		
5.2	PLASTICS Duroplastic	<150	300	0.02	0.03	0.025	0.04	0.035	0.055	0.04	0.05	0.05	0.07	0.05	0.09		

Dimension	Ø16		Ø20	
Infeed in mm	ae= 1xD	ae= 0.3xD	ae= 1xD	ae= 0.3xD
	ap= 2xD	ap= 3xD	ap= 2xD	ap= 3xD
Application				

N	Material	Strength (N/mm ²)	Feed (mm/Z)	fz			
				Vc (m/min)			
1.1	ALUMINIUM alloyed	<500	500	0.13	0.15	0.16	0.2
1.2	ALUMINIUM alloyed	<600	480	0.13	0.15	0.16	0.2
2.1-2.3	ALUMINIUM casted	<600	450	0.12	0.14	0.14	0.18
3.1-3.3	COPPER alloyed	<650	200	0.11	0.13	0.13	0.16
4.1	MAGNESIUM alloyed	<250	500	0.13	0.15	0.16	0.2
5.1	PLASTICS Thermoplastic	<100	350	0.1	0.13	0.13	0.17
5.2	PLASTICS Duroplastic	<150	300	0.09	0.12	0.12	0.16

NOTE | The values marked in turquoise are side applications!

Cooling	
Tolerance	h6
Coating	AlphaSlide Rainbow

Strategy	ETC	
Application		
Features	HA \neq	

- Chip breaker for short, defined chip length
 - Unequal tooth pitch combined with variable helical pitch for smooth running
 - Reinforced face with 2 cutting edges to the center
-
- For roughing and finishing under ETC conditions
 - For process reliable, helical diving and immersion
-
- Ideal chip evacuation, even with high radial depth of cutting

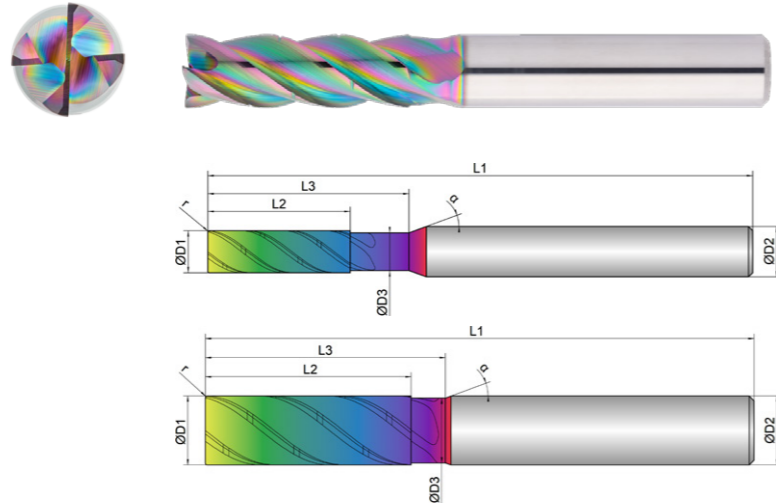

Download Catalog Pages (PDF)

Dimension	Ø5	Ø6	Ø8	Ø10	Ø12	Ø16	Ø20
Infeed in mm	ae= 0.15xD ap= L2 max	ae= 0.15xD ap= L2 max	ae= 0.15xD ap= L2 max	ae= 0.15xD ap= L2 max	ae= 0.15xD ap= L2 max	ae= 0.15xD ap= L2 max	ae= 0.15xD ap= L2 max
Application							

N	Material	Strength (N/mm ²)	Feed (mm/Z)	Feed (mm/Z)						
				fz	fz	fz	fz	fz	fz	fz
NON-FERROUS										
1.1	ALUMINIUM alloyed	<500	520	0.045	0.055	0.075	0.09	0.11	0.15	0.18
1.2	ALUMINIUM alloyed	<600	500	0.045	0.055	0.075	0.09	0.11	0.15	0.18
2.1-2.3	ALUMINIUM casted	<600	480	0.04	0.05	0.07	0.08	0.1	0.14	0.17
3.1-3.3	COPPER alloyed	<650	220	0.03	0.04	0.06	0.07	0.09	0.13	0.16
4.1	MAGNESIUM alloyed	<250	520	0.045	0.055	0.075	0.09	0.11	0.15	0.18
5.1	PLASTICS Thermoplastic	<100								
5.2	PLASTICS Duroplastic	<150								

NOTE | From Ø 10 we recommend the use of HB shank and side lock arbor (EXN1-M03-0034).

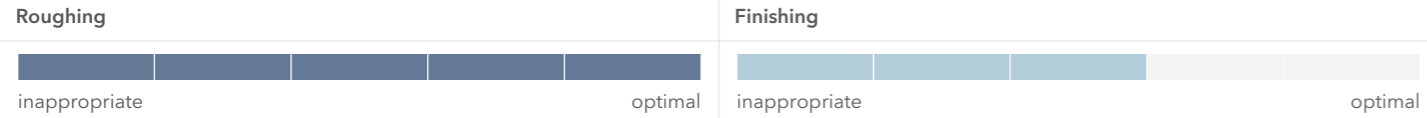

EXN1-M03-0033	D1	D3	L2	L3	L1	D2	z	r		α
	mm Ø	mm Ø	mm	mm	mm	mm Ø	#	mm		
5	5.0	4.5	17.0	24.0	65.0	6.0	4	0.15	38	20
6	6.0	5.5	18.0	25.0	65.0	6.0	4	0.15	38	20
8	8.0	7.5	24.0	30.0	70.0	8.0	4	0.20	38	20
10	10.0	9.4	30.0	35.0	80.0	10.0	4	0.20	38	20
12	12.0	11.4	36.0	45.0	93.0	12.0	4	0.20	38	20
16	16.0	15.4	48.0	55.0	110.0	16.0	4	0.30	38	20
20	20.0	19.4	60.0	70.0	125.0	20.0	4	0.30	38	20

STILL CAN'T FIND A SUITABLE MILLING CUTTER?

No problem - simply customize an existing tool. Using our configurator for special milling cutters, you can customize existing tools to your needs in an instant or create your own tools based on predefined types.



WE WILL RESPOND TO ALL REQUESTS SUBMITTED VIA THE CONFIGURATOR WITHIN ONE WORKING DAY AT THE LATEST

Cooling

Tolerance h6

Coating AlphaSlide Rainbow

Strategy ETC

Application

Features HB \neq

- Chip breaker for short, defined chip length
 - Unequal tooth pitch combined with variable helical pitch for smooth running
 - Reinforced face with 2 cutting edges to the center
-
- For roughing and finishing under ETC conditions
 - For process reliable, helical diving and immersion
-
- Ideal chip evacuation, even with high radial depth of cutting

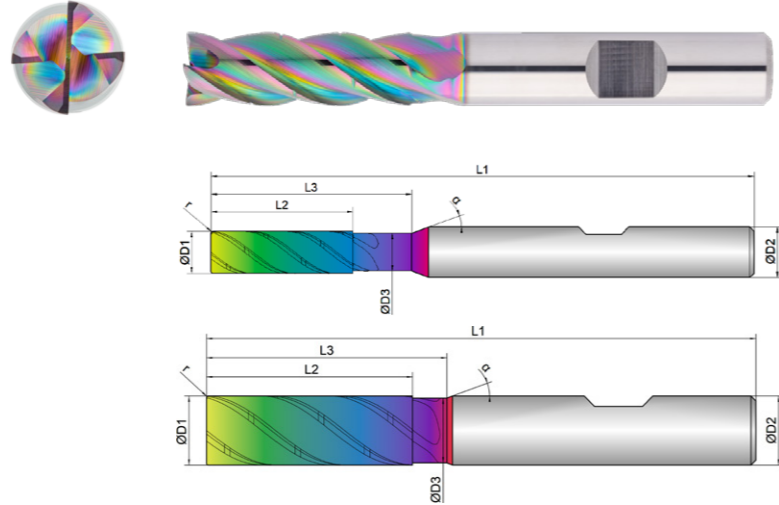

Download Catalog Pages (PDF)

Dimension	Ø5	Ø6	Ø8	Ø10	Ø12	Ø16	Ø20
Infeed in mm	ae= 0.15xD	ae= 0.15xD	ae= 0.15xD	ae= 0.15xD	ae= 0.15xD	ae= 0.15xD	ae= 0.15xD
	ap= L2 max	ap= L2 max	ap= L2 max	ap= L2 max	ap= L2 max	ap= L2 max	ap= L2 max
Application							

N	Material	Strength (N/mm ²)	Feed (mm/Z)	Feed (mm/Z)						
				fz	fz	fz	fz	fz	fz	fz
	NON-FERROUS		Vc (m/min)							
1.1	ALUMINIUM alloyed	<500	520	0.045	0.055	0.075	0.09	0.11	0.15	0.18
1.2	ALUMINIUM alloyed	<600	500	0.045	0.055	0.075	0.09	0.11	0.15	0.18
2.1-2.3	ALUMINIUM casted	<600	480	0.04	0.05	0.07	0.08	0.1	0.14	0.17
3.1-3.3	COPPER alloyed	<650	220	0.03	0.04	0.06	0.07	0.09	0.13	0.16
4.1	MAGNESIUM alloyed	<250	520	0.045	0.055	0.075	0.09	0.11	0.15	0.18
5.1	PLASTICS Thermoplastic	<100								
5.2	PLASTICS Duroplastic	<150								

Roughing

Finishing

EXN1-M03-0034	D1	D3	L2	L3	L1	D2	z	r	α
	mm	mm	mm	mm	mm	mm	#	mm	°
5	5.0	4.5	17.0	24.0	65.0	6.0	4	0.15	38
6	6.0	5.5	18.0	25.0	65.0	6.0	4	0.15	38
8	8.0	7.5	24.0	30.0	70.0	8.0	4	0.20	38
10	10.0	9.4	30.0	35.0	80.0	10.0	4	0.20	38
12	12.0	11.4	36.0	45.0	93.0	12.0	4	0.20	38
16	16.0	15.4	48.0	55.0	110.0	16.0	4	0.30	38
20	20.0	19.4	60.0	70.0	125.0	20.0	4	0.30	38

Cooling

Tolerance h6

Coating AlphaSlide Rainbow

Strategy **ETC**

Application

Features **HA** **≠** **4xD**

- Chip breaker for short, defined chip length
 - Unequal tooth pitch combined with variable helical pitch for smooth running
 - Reinforced face with 2 cutting edges to the center
-
- For roughing and finishing under ETC conditions
 - For process reliable, helical immersion
-
- Ideal chip evacuation, even with high radial depth of cutting

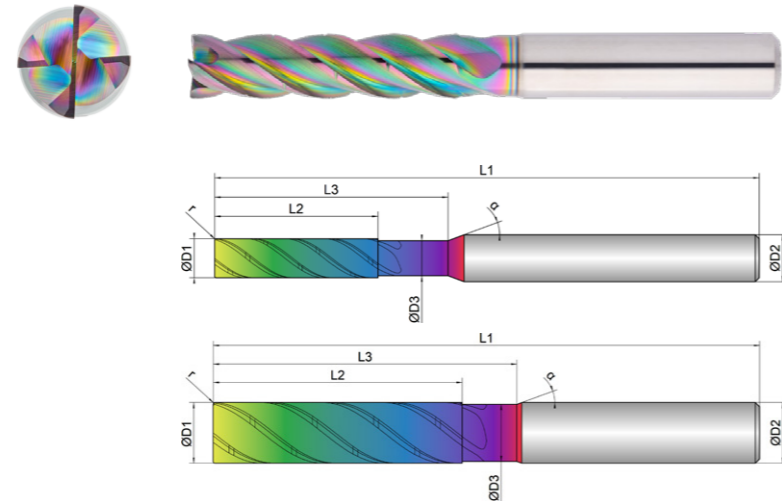

Download Catalog Pages (PDF)

Dimension	Ø5	Ø6	Ø8	Ø10	Ø12	Ø16	Ø20
Infeed in mm	ae= 0.1xD ap= L2 max	ae= 0.1xD ap= L2 max	ae= 0.1xD ap= L2 max	ae= 0.1xD ap= L2 max	ae= 0.1xD ap= L2 max	ae= 0.1xD ap= L2 max	ae= 0.1xD ap= L2 max
Application							











N	Material	Strength (N/mm ²)	Feed (mm/Z)	Feed (mm/Z)						
				fz	fz	fz	fz	fz	fz	fz
NON-FERROUS										
			Vc (m/min)							
1.1	ALUMINIUM alloyed	<500	520	0.04	0.05	0.07	0.085	0.1	0.14	0.17
1.2	ALUMINIUM alloyed	<600	500	0.04	0.05	0.07	0.085	0.1	0.14	0.17
2.1-2.3	ALUMINIUM casted	<600	480	0.035	0.045	0.065	0.08	0.09	0.13	0.16
3.1-3.3	COPPER alloyed	<650	220	0.025	0.035	0.06	0.075	0.08	0.12	0.15
4.1	MAGNESIUM alloyed	<250	520	0.04	0.05	0.07	0.085	0.1	0.14	0.17
5.1	PLASTICS Thermoplastic	<100								
5.2	PLASTICS Duroplastic	<150								

NOTE | From Ø 10 we recommend the use of HB shank and side lock arbor (EXN1-M03-0044).

Roughing **Finishing**

EXN1-M03-0043	D1	D3	L2	L3	L1	D2	z	r		α
	mm Ø	mm Ø	mm	mm	mm	mm Ø	#	mm		
5	5.0	4.5	21.0	30.0	70.0	6.0	4	0.15	38	20
6	6.0	5.5	25.0	30.0	70.0	6.0	4	0.15	38	20
8	8.0	7.5	33.0	40.0	80.0	8.0	4	0.20	38	20
10	10.0	9.4	41.0	50.0	90.0	10.0	4	0.20	38	20
12	12.0	11.4	49.0	60.0	110.0	12.0	4	0.20	38	20
16	16.0	15.4	65.0	80.0	130.0	16.0	4	0.30	38	20
20	20.0	19.4	82.0	100.0	150.0	20.0	4	0.30	38	20





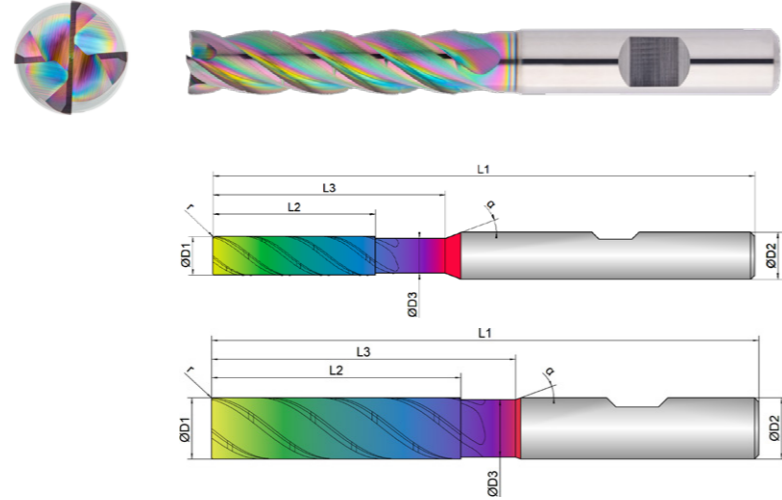

Cooling 
Tolerance h6
Coating AlphaSlide Rainbow

Strategy ETC 
Application 
Features HB  ≠       



- Chip breaker for short, defined chip length
 - Unequal tooth pitch combined with variable helical pitch for smooth running
 - Reinforced face with 2 cutting edges to the center
-
- For roughing and finishing under ETC conditions
 - For process reliable, helical immersion
-
- Ideal chip evacuation, even with high radial depth of cutting





Download Catalog Pages (PDF)

Dimension	Ø5	Ø6	Ø8	Ø10	Ø12	Ø16	Ø20
Infeed in mm	ae= 0.1xD ap= L2 max	ae= 0.1xD ap= L2 max	ae= 0.1xD ap= L2 max	ae= 0.1xD ap= L2 max	ae= 0.1xD ap= L2 max	ae= 0.1xD ap= L2 max	ae= 0.1xD ap= L2 max
Application							

N	Material	Strength (N/mm ²)	Feed (mm/Z)	Feed (mm/Z)						
				fz	fz	fz	fz	fz	fz	fz
NON-FERROUS										
			Vc (m/min)							
1.1	ALUMINIUM alloyed	<500	520	0.04	0.05	0.07	0.085	0.1	0.14	0.17
1.2	ALUMINIUM alloyed	<600	500	0.04	0.05	0.07	0.085	0.1	0.14	0.17
2.1-2.3	ALUMINIUM casted	<600	480	0.035	0.045	0.065	0.08	0.09	0.13	0.16
3.1-3.3	COPPER alloyed	<650	220	0.025	0.035	0.06	0.075	0.08	0.12	0.15
4.1	MAGNESIUM alloyed	<250	520	0.04	0.05	0.07	0.085	0.1	0.14	0.17
5.1	PLASTICS Thermoplastic	<100								
5.2	PLASTICS Duroplastic	<150								

Roughing  **Finishing** 
 inappropriate | optimal | inappropriate | optimal

EXN1-M03-0044	D1	D3	L2	L3	L1	D2	z	r		α
	mm \varnothing	mm \varnothing	mm	mm	mm	mm \varnothing	#	mm		
5	5.0	4.5	21.0	30.0	70.0	6.0	4	0.15	38	20
6	6.0	5.5	25.0	30.0	70.0	6.0	4	0.15	38	20
8	8.0	7.5	33.0	40.0	80.0	8.0	4	0.20	38	20
10	10.0	9.4	41.0	50.0	90.0	10.0	4	0.20	38	20
12	12.0	11.4	49.0	60.0	110.0	12.0	4	0.20	38	20
16	16.0	15.4	65.0	80.0	130.0	16.0	4	0.30	38	20
20	20.0	19.4	82.0	100.0	150.0	20.0	4	0.30	38	20

Cooling 

Tolerance h6

Coating AlphaSlide Rainbow

Strategy **ETC** 



Application 

Features **HA** 

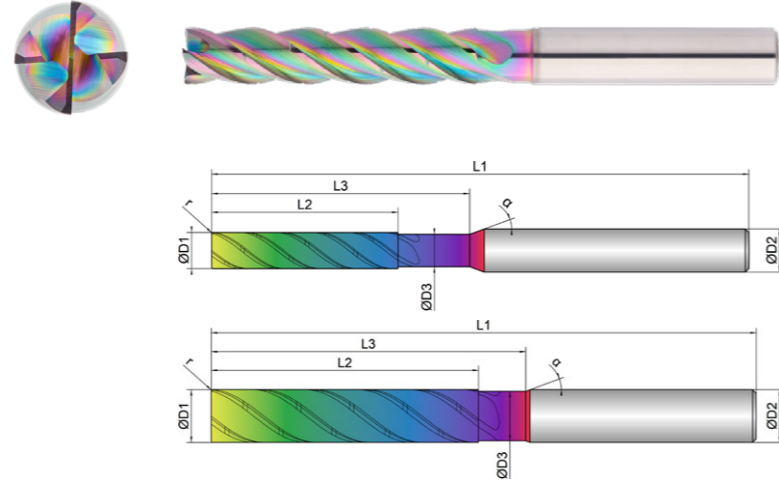
- Chip breaker for short, defined chip length
 - Unequal tooth pitch combined with variable helical pitch for smooth running
 - Reinforced face with 2 cutting edges to the center
-
- For roughing and finishing under ETC conditions
 - For process reliable, helical immersion
-
- Ideal chip evacuation, even with high radial depth of cutting





Download Catalog Pages (PDF)

Dimension	Ø5	Ø6	Ø8	Ø10	Ø12	Ø16	Ø20
Infeed in mm	ae= 0.07xD ap= L2 max	ae= 0.07xD ap= L2 max	ae= 0.07xD ap= L2 max	ae= 0.07xD ap= L2 max	ae= 0.07xD ap= L2 max	ae= 0.07xD ap= L2 max	ae= 0.07xD ap= L2 max
Application							

N	Material	Strength (N/mm ²)	Feed (mm/Z)	Feed (mm/Z)						
				fz	fz	fz	fz	fz	fz	fz
NON-FERROUS				Vc (m/min)						
1.1	ALUMINIUM alloyed	<500	500	0.035	0.05	0.065	0.08	0.095	0.13	0.16
1.2	ALUMINIUM alloyed	<600	480	0.035	0.05	0.065	0.08	0.095	0.13	0.16
2.1-2.3	ALUMINIUM casted	<600	460	0.03	0.045	0.06	0.07	0.085	0.12	0.15
3.1-3.3	COPPER alloyed	<650	200	0.02	0.04	0.05	0.06	0.075	0.11	0.14
4.1	MAGNESIUM alloyed	<250	500	0.035	0.045	0.065	0.08	0.095	0.13	0.16
5.1	PLASTICS Thermoplastic	<100								
5.2	PLASTICS Duroplastic	<150								

NOTE | From Ø 10 we recommend the use of HB shank and side lock arbor (EXN1-M03-0054).

Roughing  **Finishing** 

EXN1-M03-0053	D1	D3	L2	L3	L1	D2	z	r		α
	mm Ø	mm Ø	mm	mm	mm	mm Ø	#	mm	°	°
5	5.0	4.5	26.0	36.0	75.0	6.0	4	0.15	38	20
6	6.0	5.5	31.0	36.0	75.0	6.0	4	0.15	38	20
8	8.0	7.5	41.0	48.0	90.0	8.0	4	0.20	38	20
10	10.0	9.5	51.0	60.0	104.0	10.0	4	0.20	38	20
12	12.0	11.0	61.0	72.0	120.0	12.0	4	0.20	38	20
16	16.0	15.0	81.0	96.0	150.0	16.0	4	0.30	38	20
20	20.0	19.0	102.0	120.0	175.0	20.0	4	0.30	38	20

Cooling

Tolerance h6

Coating AlphaSlide Rainbow

Strategy ETC

Application

Features HB \neq

- Chip breaker for short, defined chip length
 - Unequal tooth pitch combined with variable helical pitch for smooth running
 - Reinforced face with 2 cutting edges to the center
- For roughing and finishing under ETC conditions
 - For process reliable, helical immersion
- Ideal chip evacuation, even with high radial depth of cutting

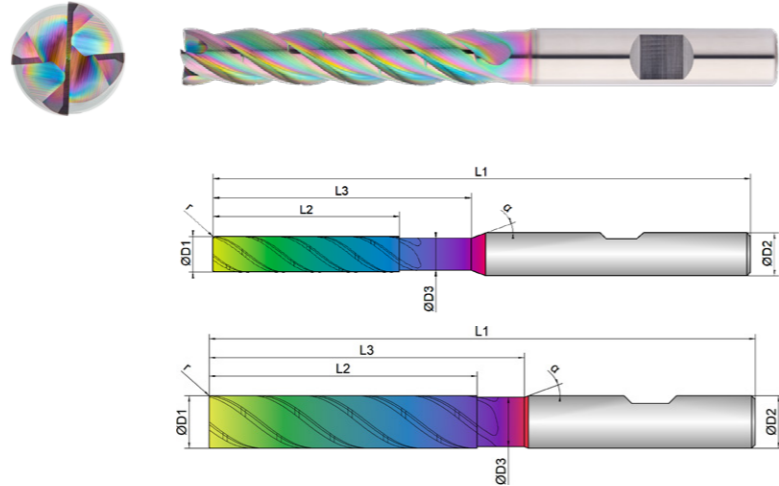

Download Catalog Pages (PDF)

Dimension	Ø5	Ø6	Ø8	Ø10	Ø12	Ø16	Ø20
Infeed in mm	ae= 0.07xD ap= L2 max	ae= 0.07xD ap= L2 max	ae= 0.07xD ap= L2 max	ae= 0.07xD ap= L2 max	ae= 0.07xD ap= L2 max	ae= 0.07xD ap= L2 max	ae= 0.07xD ap= L2 max
Application							

N	Material	Strength (N/mm ²)	Feed (mm/Z)	Feed (mm/Z)						
				fz	fz	fz	fz	fz	fz	fz
NON-FERROUS										
				Vc (m/min)						
1.1	ALUMINIUM alloyed	<500	500	0.035	0.05	0.065	0.08	0.095	0.13	0.16
1.2	ALUMINIUM alloyed	<600	480	0.035	0.05	0.065	0.08	0.095	0.13	0.16
2.1-2.3	ALUMINIUM casted	<600	460	0.03	0.045	0.06	0.07	0.085	0.12	0.15
3.1-3.3	COPPER alloyed	<650	200	0.02	0.04	0.05	0.06	0.075	0.11	0.14
4.1	MAGNESIUM alloyed	<250	500	0.035	0.045	0.065	0.08	0.095	0.13	0.16
5.1	PLASTICS Thermoplastic	<100								
5.2	PLASTICS Duroplastic	<150								

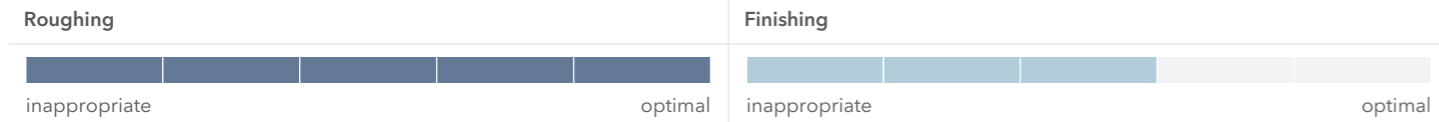

EXN1-M03-0054	D1	D3	L2	L3	L1	D2	z	r	α	
	mm Ø	mm Ø	mm	mm	mm	mm Ø	#	mm		
5	5.0	4.5	26.0	36.0	75.0	6.0	4	0.15	38	20
6	6.0	5.5	31.0	36.0	75.0	6.0	4	0.15	38	20
8	8.0	7.5	41.0	48.0	90.0	8.0	4	0.20	38	20
10	10.0	9.5	51.0	60.0	104.0	10.0	4	0.20	38	20
12	12.0	11.0	61.0	72.0	120.0	12.0	4	0.20	38	20
16	16.0	15.0	81.0	96.0	150.0	16.0	4	0.30	38	20
20	20.0	19.0	102.0	120.0	175.0	20.0	4	0.30	38	20

Cooling

Tolerance h6

Coating AlphaSlide Rainbow

Strategy ETC

Application

Features HA



Download Catalog Pages (PDF)

Dimension	Ø12	Ø16
Infeed in mm	ae= 0.15xD ap= L2 max	ae= 0.15xD ap= L2 max
Application		

- Special aerospace geometry optimized for vibration-free milling and ideal chip removal for thin-walled workpieces and complex internal machining



- Adapted chip breaker for defined chip length and maximum tool life
- Unequal tooth pitch combined with variable helical pitch for smooth running and a soft cut

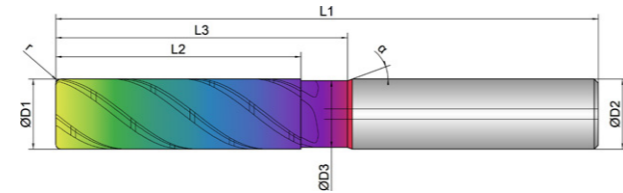

- Radius tolerance $r \leq 1.5$ mm: ± 0.003 mm
- Radius tolerance $r > 1.5$ mm: ± 0.005 mm

N	Material	Strength (N/mm ²)	Feed (mm/Z)	Vc (m/min)	
				fz	fz
1.1	ALUMINIUM alloyed	<500	520	0.11	0.15
1.2	ALUMINIUM alloyed	<600	500	0.11	0.15
2.1-2.3	ALUMINIUM casted	<600	480	0.1	0.14
3.1-3.3	COPPER alloyed	<650	220	0.09	0.13
4.1	MAGNESIUM alloyed	<250	520	0.11	0.15
5.1	PLASTICS Thermoplastic	<100			
5.2	PLASTICS Duroplastic	<150			

Roughing

Finishing



	D1	D3	L2	L3	L1	D2	z	r		α
EXN1-M03-0133										
	mm Ø	mm Ø	mm	mm	mm	mm Ø	#	mm	°	°
12/0,8	12.0	11.4	42.0	50.0	93.0	12.0	4	0.80	38	20
16/1	16.0	15.4	55.0	66.0	110.0	16.0	4	1.00	38	20

Cooling	
Tolerance	h6
Coating	AlphaSlide Rainbow

Strategy	HPC	
Application		
Features	HA \neq 3xD	

- Ultra-sharp and lapped cutting edges
- Special chip chambers designed for the evacuation of extra long and fine chips
- Face-Finish-bevel for smooth workpiece surfaces
- For excellent surfaces and maximum dimensional accuracy
- 6 cutting edges for highest feed rates

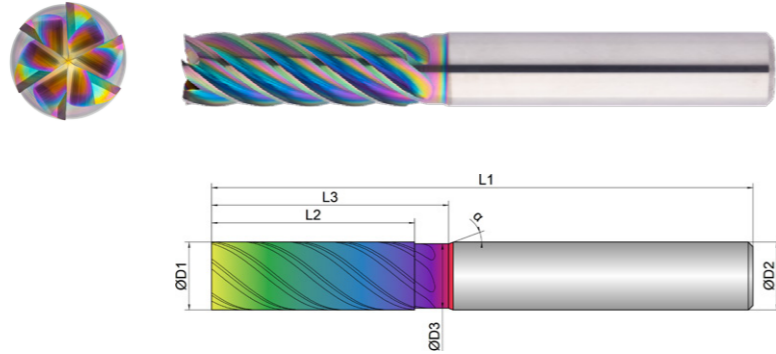

Roughing					Finishing				
inappropriate					optimal				
inappropriate					optimal				

EXN1-M04-0033	D1	D3	L2	L3	L1	D2	z	α
	mm Ø	mm Ø	mm	mm	mm	mm Ø	#	°
6	6.0	5.8	18.0	25.0	65.0	6.0	6	39
8	8.0	7.8	24.0	30.0	70.0	8.0	6	39
10	10.0	9.5	30.0	35.0	80.0	10.0	6	39
12	12.0	11.5	36.0	45.0	93.0	12.0	6	39
16	16.0	15.5	48.0	55.0	110.0	16.0	6	39
20	20.0	19.5	60.0	70.0	125.0	20.0	6	39



Download Catalog Pages (PDF)

Dimension	Ø6	Ø8	Ø10	Ø12	Ø16	Ø20
Infeed in mm	ae=0.05xD ap=L2 max	ae=0.05xD ap=L2 max	ae=0.05xD ap=L2 max	ae=0.05xD ap=L2 max	ae=0.05xD ap=L2 max	ae=0.05xD ap=L2 max
Application						

N	Material	Strength (N/mm ²)	Feed (mm/Z)	Feed (mm/Z)					
				fz	fz	fz	fz	fz	fz
NON-FERROUS									
1.1	ALUMINIUM alloyed	<500	380	0.03	0.032	0.034	0.036	0.038	0.04
1.2	ALUMINIUM alloyed	<600	360	0.03	0.032	0.034	0.036	0.038	0.04
2.1-2.3	ALUMINIUM casted	<600	320	0.025	0.027	0.029	0.031	0.033	0.035
3.1-3.3	COPPER alloyed	<650	160	0.02	0.022	0.024	0.026	0.028	0.03
4.1	MAGNESIUM alloyed	<250	350	0.03	0.032	0.034	0.036	0.038	0.04
5.1	PLASTICS Thermoplastic	<100	300	0.025	0.027	0.029	0.031	0.033	0.035
5.2	PLASTICS Duroplastic	<150	260	0.02	0.022	0.024	0.026	0.028	0.03

NOTE | To achieve high surface quality, use ae = 0.2mm for Ø6-10; ae = 0.3mm for Ø12-20.

STILL CAN'T FIND A SUITABLE MILLING CUTTER?

No problem - simply customize an existing tool. Using our configurator for special milling cutters, you can customize existing tools to your needs in an instant or create your own tools based on predefined types.



WE WILL RESPOND TO ALL REQUESTS SUBMITTED VIA THE CONFIGURATOR WITHIN ONE WORKING DAY AT THE LATEST

Cooling	
Tolerance	h6
Coating	AlphaSlide Rainbow

Strategy	HPC	
Application		
Features	HA \neq 4xD	

- Ultra-sharp and lapped cutting edges
 - Special chip chambers designed for the evacuation of extra long and fine chips
 - Face-Finish-bevel for smooth workpiece surfaces
-
- For excellent surfaces and maximum dimensional accuracy
-
- 6 cutting edges for highest feed rates

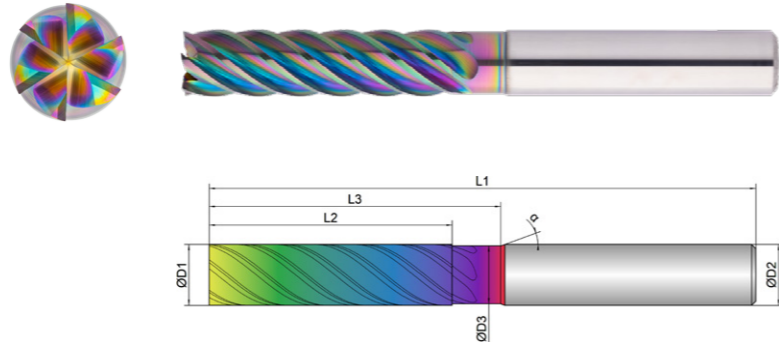

Roughing

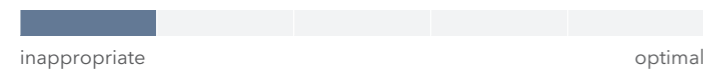

Finishing



EXN1-M04-0043	D1 mm ∅	D3 mm ∅	L2 mm	L3 mm	L1 mm	D2 mm ∅	z #	 °	α °
6	6.0	5.8	24.0	32.0	65.0	6.0	6	39	20
8	8.0	7.8	32.0	40.0	75.0	8.0	6	39	20
10	10.0	9.5	40.0	48.0	90.0	10.0	6	39	20
12	12.0	11.5	48.0	56.0	100.0	12.0	6	39	20
16	16.0	15.5	64.0	72.0	125.0	16.0	6	39	20
20	20.0	19.5	80.0	88.0	150.0	20.0	6	39	20



Download Catalog Pages (PDF)

Dimension	∅6	∅8	∅10	∅12	∅16	∅20
Infeed in mm	ae= 0.05xD ap= L2 max	ae= 0.05xD ap= L2 max	ae= 0.05xD ap= L2 max	ae= 0.05xD ap= L2 max	ae= 0.05xD ap= L2 max	ae= 0.05xD ap= L2 max
Application						

N	Material	Strength (N/mm ²)	Feed (mm/Z)	Feed (mm/Z)					
				fz	fz	fz	fz	fz	fz
NON-FERROUS									
			Vc (m/min)						
1.1	ALUMINIUM alloyed	<500	380	0.03	0.032	0.034	0.036	0.038	0.04
1.2	ALUMINIUM alloyed	<600	360	0.03	0.032	0.034	0.036	0.038	0.04
2.1-2.3	ALUMINIUM casted	<600	320	0.025	0.027	0.029	0.031	0.033	0.035
3.1-3.3	COPPER alloyed	<650	160	0.02	0.022	0.024	0.026	0.028	0.03
4.1	MAGNESIUM alloyed	<250	350	0.03	0.032	0.034	0.036	0.038	0.04
5.1	PLASTICS Thermoplastic	<100	300	0.025	0.027	0.029	0.031	0.033	0.035
5.2	PLASTICS Duroplastic	<150	260	0.02	0.022	0.024	0.026	0.028	0.03

NOTE | To achieve high surface quality, use ae = 0.2mm for ∅6-10; ae = 0.3mm for ∅12-20.

Cooling

Tolerance h6

Coating AlphaSlide Rainbow

Strategy **HPC**

Application

Features **HA** **≠** **5xD**

- Ultra-sharp and lapped cutting edges
- Special chip chambers designed for the evacuation of extra long and fine chips
- Face-Finish-bevel for smooth workpiece surfaces
- For excellent surfaces and maximum dimensional accuracy
- 6 cutting edges for highest feed rates

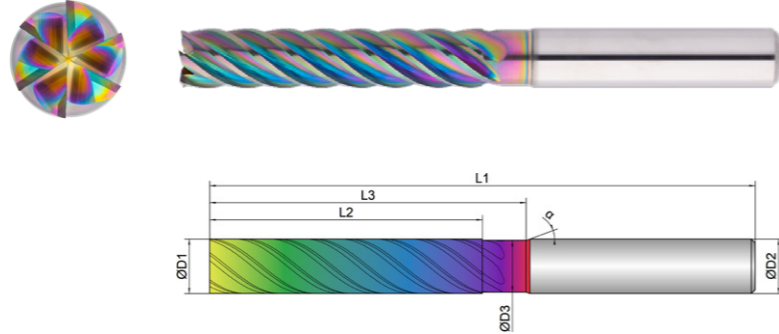

Roughing

inappropriate optimal

Finishing

inappropriate optimal

EXN1-M04-0053	D1	D3	L2	L3	L1	D2	z		α
	mm ∅	mm ∅	mm	mm	mm	mm ∅	#	°	°
6	6.0	5.8	30.0	38.0	75.0	6.0	6	39	20
8	8.0	7.8	40.0	48.0	80.0	8.0	6	39	20
10	10.0	9.5	50.0	58.0	100.0	10.0	6	39	20
12	12.0	11.5	60.0	68.0	120.0	12.0	6	39	20
16	16.0	15.5	80.0	88.0	134.0	16.0	6	39	20
20	20.0	19.5	100.0	108.0	175.0	20.0	6	39	20



Download Catalog Pages (PDF)

Dimension	∅6	∅8	∅10	∅12	∅16	∅20
Infeed in mm	ae= 0.05xD ap= L2 max	ae= 0.05xD ap= L2 max	ae= 0.05xD ap= L2 max	ae= 0.05xD ap= L2 max	ae= 0.05xD ap= L2 max	ae= 0.05xD ap= L2 max
Application						

N	Material	Strength (N/mm ²)	Feed (mm/Z)	Feed (mm/Z)					
				fz	fz	fz	fz	fz	fz
NON-FERROUS									
			Vc (m/min)						
1.1	ALUMINIUM alloyed	<500	380	0.026	0.028	0.03	0.032	0.034	0.036
1.2	ALUMINIUM alloyed	<600	360	0.026	0.028	0.03	0.032	0.034	0.036
2.1-2.3	ALUMINIUM casted	<600	320	0.021	0.023	0.025	0.027	0.029	0.031
3.1-3.3	COPPER alloyed	<650	160	0.016	0.018	0.02	0.022	0.024	0.026
4.1	MAGNESIUM alloyed	<250	350	0.026	0.028	0.03	0.032	0.034	0.036
5.1	PLASTICS Thermoplastic	<100	300	0.021	0.023	0.025	0.027	0.029	0.031
5.2	PLASTICS Duroplastic	<150	260	0.016	0.018	0.02	0.022	0.024	0.026

NOTE | To achieve high surface quality, use ae = 0.2mm for ∅6-10; ae = 0.3mm for ∅12-20.

Cooling

Tolerance h6

Coating AlphaSlide Rainbow

Strategy **HPC**

Application

Features **HA**

Expert

- Special aerospace geometry optimized for vibration-free milling and ideal chip removal for thin-walled workpieces and complex internal machining
- Special chip chambers designed for the evacuation of extra long and fine chips
- For excellent surfaces and maximum dimensional accuracy
- Radius tolerance $r \leq 1.5 \text{ mm}$: $\pm 0.003 \text{ mm}$
- Radius tolerance $r > 1.5 \text{ mm}$: $\pm 0.005 \text{ mm}$

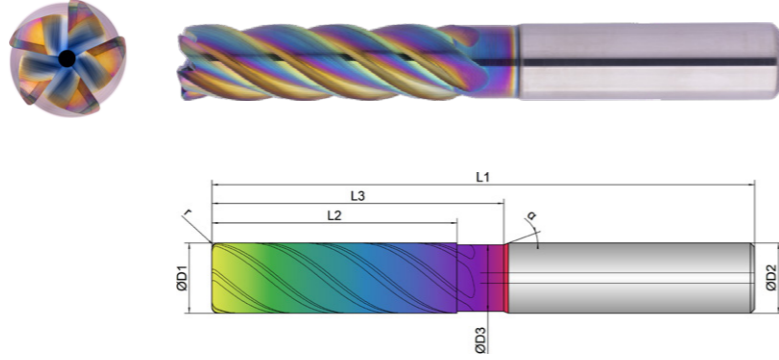

Download Catalog Pages (PDF)

Dimension	Ø12	Ø16
Infeed in mm	ae= 0.05xD ap= L2 max	ae= 0.05xD ap= L2 max
Application		

	Material	Strength (N/mm ²)	Feed (mm/Z)	fz	fz
N	NON-FERROUS		Vc (m/min)		
1.1	ALUMINIUM alloyed	<500	380	0.036	0.038
1.2	ALUMINIUM alloyed	<600	360	0.036	0.038
2.1-2.3	ALUMINIUM casted	<600	320	0.031	0.033
3.1-3.3	COPPER alloyed	<650	160	0.026	0.028
4.1	MAGNESIUM alloyed	<250	350	0.036	0.038
5.1	PLASTICS Thermoplastic	<100	300	0.031	0.033
5.2	PLASTICS Duroplastic	<150	260	0.026	0.028

NOTE | To achieve high surface quality, use ae = 0.2 mm for Ø6-10; ae = 0.3mm for Ø12-20.

Roughing

Finishing

	D1	D3	L2	L3	L1	D2	z	r		α
EXN1-M04-0133	 mm Ø	 mm Ø	 mm	 mm	 mm	 mm Ø	 #	 mm	 °	 °
12/1	12.0	11.4	42.0	50.0	93.0	12.0	5	1.00	39	20
16/3	16.0	15.5	55.0	66.0	110.0	16.0	5	3.00	39	20

Cooling	
Tolerance	h10
Coating	AlphaSlide Rainbow

Strategy	HSC	HPC	
Application			
Features	HA		

- Defined clearance angle for ideal stabilization with high cutting depths
 - Special helical pitch for smooth running and soft cut
 - Balanced for maximum smoothness
- For roughing and finishing, up to 1.5xD full slot
 - For process reliable, helical diving and immersion
- For use in high speed milling machines

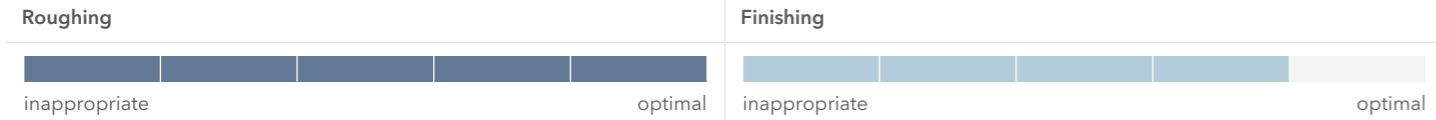
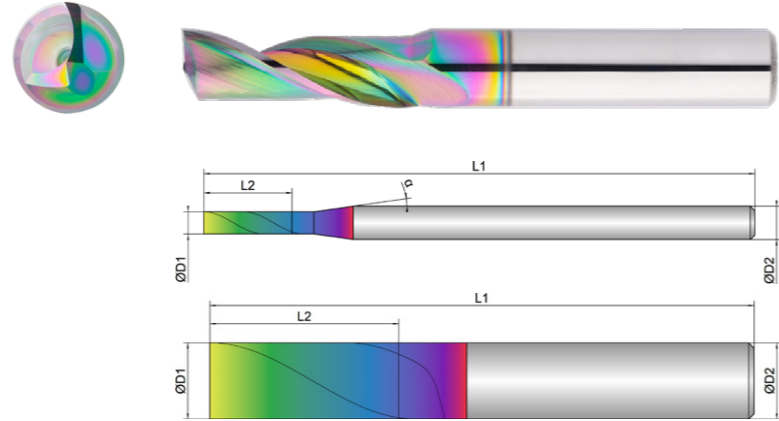

EXN1-M05-0023	D1 mm Ø	L2 mm	L1 mm	D2 mm Ø	z #	°	α °
1	1.0	4.0	50.0	3.0	1	30	8
1,5	1.5	6.0	50.0	3.0	1	30	8
2	2.0	8.0	50.0	3.0	1	30	8
3	3.0	12.0	50.0	3.0	1	30	0
4	4.0	15.0	54.0	4.0	1	30	0
5	5.0	17.0	54.0	5.0	1	30	0
6	6.0	20.0	65.0	6.0	1	30	0
8	8.0	22.0	63.0	8.0	1	30	0
10	10.0	25.0	72.0	10.0	1	30	0
12	12.0	30.0	83.0	12.0	1	30	0



Download Catalog Pages (PDF)

Dimension	Ø1		Ø1.5		Ø2		Ø3		Ø4		Ø5	
Infeed in mm	ae=1xD	ae=0.3xD	ae=1xD	ae=0.3xD	ae=1xD	ae=0.3xD	ae=1xD	ae=0.3xD	ae=1xD	ae=0.3xD	ae=1xD	ae=0.3xD
Application												

Material	Strength (N/mm ²)	Feed (mm/Z)	fz	fz	fz	fz	fz	fz	fz	fz	fz	fz	fz	fz
N NON-FERROUS		Vc (m/min)												
1.1 ALUMINIUM alloyed	<500	500	0.015	0.02	0.015	0.02	0.02	0.025	0.025	0.035	0.03	0.04	0.035	0.045
1.2 ALUMINIUM alloyed	<600	480	0.015	0.02	0.015	0.02	0.02	0.025	0.025	0.035	0.03	0.04	0.035	0.045
2.1-2.3 ALUMINIUM casted	<600	450	0.01	0.015	0.01	0.015	0.015	0.02	0.02	0.03	0.025	0.035	0.03	0.04
3.1-3.3 COPPER alloyed	<650	200	0.008	0.012	0.008	0.012	0.012	0.015	0.015	0.025	0.02	0.03	0.025	0.035
4.1 MAGNESIUM alloyed	<250	500	0.015	0.02	0.015	0.02	0.02	0.025	0.025	0.035	0.03	0.04	0.035	0.045
5.1 PLASTICS Thermoplastic	<100	400	0.01	0.015	0.01	0.015	0.015	0.02	0.02	0.03	0.025	0.035	0.03	0.04
5.2 PLASTICS Duroplastic	<150	350	0.008	0.012	0.008	0.012	0.012	0.015	0.015	0.025	0.02	0.03	0.025	0.035

Dimension	Ø6		Ø8		Ø10		Ø12	
Infeed in mm	ae=1xD	ae=0.3xD	ae=1xD	ae=0.3xD	ae=1xD	ae=0.3xD	ae=1xD	ae=0.3xD
Application								

Material	Strength (N/mm ²)	Feed (mm/Z)	fz	fz	fz	fz	fz	fz	fz	fz
N NON-FERROUS		Vc (m/min)								
1.1 ALUMINIUM alloyed	<500	500	0.045	0.055	0.05	0.06	0.06	0.07	0.075	0.1
1.2 ALUMINIUM alloyed	<600	480	0.045	0.055	0.05	0.06	0.06	0.07	0.075	0.1
2.1-2.3 ALUMINIUM casted	<600	450	0.04	0.05	0.045	0.055	0.055	0.065	0.07	0.09
3.1-3.3 COPPER alloyed	<650	200	0.035	0.045	0.04	0.05	0.05	0.06	0.06	0.08
4.1 MAGNESIUM alloyed	<250	500	0.045	0.055	0.05	0.06	0.06	0.07	0.075	0.1
5.1 PLASTICS Thermoplastic	<100	400	0.04	0.05	0.045	0.055	0.055	0.065	0.07	0.09
5.2 PLASTICS Duroplastic	<150	350	0.035	0.045	0.04	0.05	0.05	0.06	0.06	0.08

Cooling

Tolerance h10

Coating AlphaSlide Rainbow

Strategy **HSC** **HPC**

Application

Features **HA**

Expert

- Defined clearance angle for ideal stabilization with high cutting depths
 - Special helical pitch for smooth running and soft cut
 - Balanced for maximum smoothness
- For roughing and finishing, up to 1.5xD full slot
 - For process reliable, helical diving and immersion
- For use in high speed milling machines
 - Long version with extra long cutting length

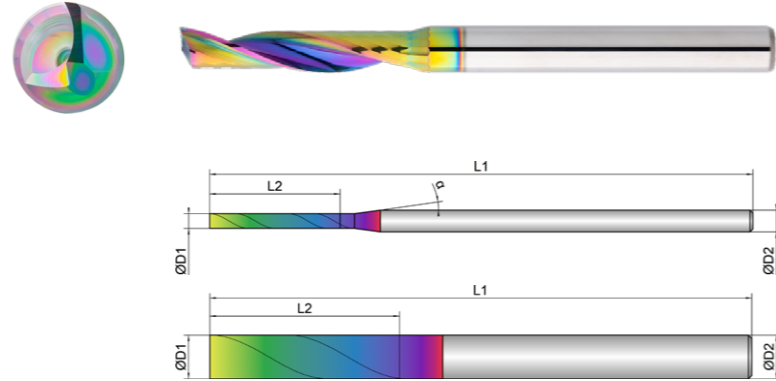

Roughing

Finishing

EXN1-M05-0053	D1 mm ø	L2 mm	L1 mm	D2 mm ø	z #	 °	α °
1	1.0	8.0	75.0	3.0	1	30	8
1,5	1.5	12.0	75.0	3.0	1	30	8
2	2.0	18.0	75.0	3.0	1	30	8
3	3.0	22.0	75.0	3.0	1	30	0
4	4.0	25.0	75.0	4.0	1	30	0
5	5.0	25.0	75.0	5.0	1	30	0
6	6.0	30.0	100.0	6.0	1	30	0
8	8.0	35.0	100.0	8.0	1	30	0
10	10.0	40.0	100.0	10.0	1	30	0
12	12.0	45.0	120.0	12.0	1	30	0



Download Catalog Pages (PDF)

Dimension	Ø1		Ø1.5		Ø2		Ø3		Ø4		Ø5	
Infeed in mm	ae=1xD	ae=0.3xD	ae=1xD	ae=0.3xD	ae=1xD	ae=0.3xD	ae=1xD	ae=0.3xD	ae=1xD	ae=0.3xD	ae=1xD	ae=0.3xD
Application												

N	Material	Strength (N/mm ²)	Feed (mm/Z)	fz											
				Vc (m/min)											
1.1	ALUMINIUM alloyed	<500	450	0.008	0.012	0.008	0.012	0.015	0.02	0.02	0.025	0.025	0.03	0.03	0.038
1.2	ALUMINIUM alloyed	<600	425	0.008	0.012	0.008	0.012	0.015	0.02	0.02	0.025	0.025	0.03	0.03	0.038
2.1-2.3	ALUMINIUM casted	<600	400	0.006	0.01	0.006	0.01	0.01	0.015	0.015	0.02	0.02	0.025	0.025	0.033
3.1-3.3	COPPER alloyed	<650	170	0.004	0.008	0.004	0.008	0.008	0.01	0.01	0.015	0.015	0.02	0.02	0.028
4.1	MAGNESIUM alloyed	<250	450	0.008	0.012	0.008	0.012	0.015	0.02	0.02	0.025	0.025	0.03	0.03	0.038
5.1	PLASTICS Thermoplastic	<100	350	0.006	0.01	0.006	0.01	0.01	0.015	0.015	0.02	0.02	0.025	0.025	0.033
5.2	PLASTICS Duroplastic	<150	300	0.004	0.008	0.004	0.008	0.008	0.01	0.01	0.015	0.015	0.02	0.02	0.028

Dimension	Ø6		Ø8		Ø10		Ø12	
Infeed in mm	ae=1xD	ae=0.3xD	ae=1xD	ae=0.3xD	ae=1xD	ae=0.3xD	ae=1xD	ae=0.3xD
Application								

N	Material	Strength (N/mm ²)	Feed (mm/Z)	fz							
				Vc (m/min)							
1.1	ALUMINIUM alloyed	<500	450	0.038	0.048	0.043	0.053	0.05	0.06	0.065	0.09
1.2	ALUMINIUM alloyed	<600	425	0.038	0.048	0.043	0.053	0.05	0.06	0.065	0.09
2.1-2.3	ALUMINIUM casted	<600	400	0.033	0.043	0.038	0.048	0.045	0.055	0.06	0.08
3.1-3.3	COPPER alloyed	<650	170	0.028	0.038	0.033	0.043	0.04	0.05	0.055	0.07
4.1	MAGNESIUM alloyed	<250	450	0.038	0.048	0.043	0.053	0.05	0.06	0.065	0.09
5.1	PLASTICS Thermoplastic	<100	350	0.033	0.043	0.038	0.048	0.045	0.055	0.06	0.08
5.2	PLASTICS Duroplastic	<150	300	0.028	0.038	0.033	0.043	0.04	0.05	0.055	0.07

Cooling	
Tolerance	h6
Coating	AlphaSlide Rainbow

Strategy	HSC	HPC		
Application				
Features	HA	≠	2xD	

- Defined clearance angle for ideal stabilization with high cutting depths
 - Special helical pitch for smooth running and soft cut
 - Extra large chip chambers for an extreme chip volume
- For process reliable, helical diving and immersion
 - For roughing and finishing, up to 1.5xD full slot
 - Multipass milling of 3D contours
- Radius tolerance $r \leq 1.5 \text{ mm}$: $\pm 0.003 \text{ mm}$
 - Radius tolerance $r > 1.5 \text{ mm}$: $\pm 0.005 \text{ mm}$

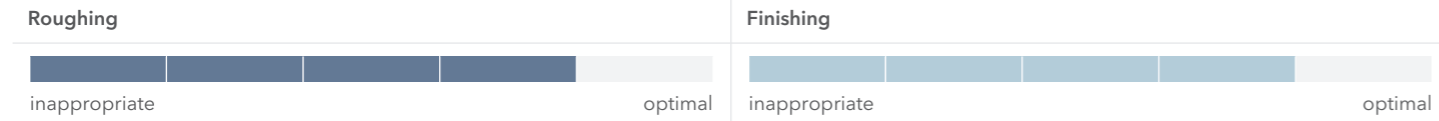
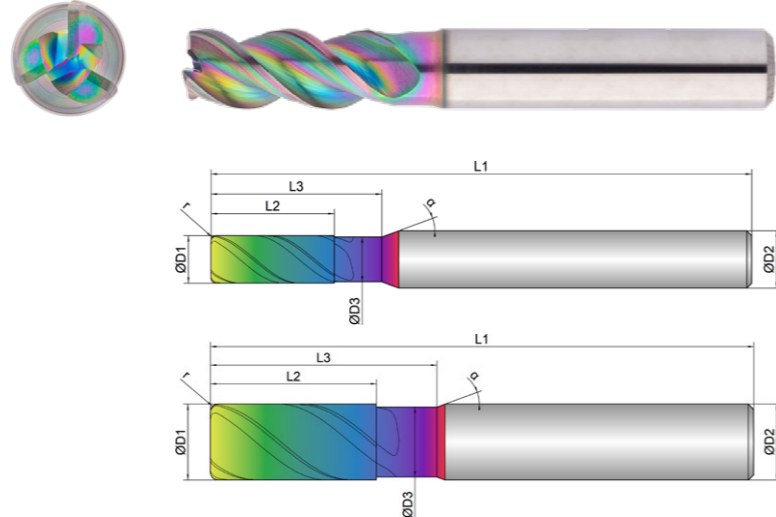

EXN1-M06-0003	D1 mm ∅	D3 mm ∅	L2 mm	L3 mm	L1 mm	D2 mm ∅	z #	r mm	α °
5/0,5	5.0	4.7	13.0	18.0	57.0	6.0	3	0.50	45
5/1	5.0	4.7	13.0	18.0	57.0	6.0	3	1.00	45
6/0,5	6.0	5.7	13.0	18.0	57.0	6.0	3	0.50	45
6/1	6.0	5.7	13.0	18.0	57.0	6.0	3	1.00	45
8/0,5	8.0	7.4	21.0	25.0	63.0	8.0	3	0.50	45
8/1	8.0	7.4	21.0	25.0	63.0	8.0	3	1.00	45
10/0,5	10.0	9.2	22.0	30.0	72.0	10.0	3	0.50	45
10/1	10.0	9.2	22.0	30.0	72.0	10.0	3	1.00	45
10/1,5	10.0	9.2	22.0	30.0	72.0	10.0	3	1.50	45
10/2	10.0	9.2	22.0	30.0	72.0	10.0	3	2.00	45

EXN1-M06-0003	D1 mm ∅	D3 mm ∅	L2 mm	L3 mm	L1 mm	D2 mm ∅	z #	r mm	α °
10/2,5	10.0	9.2	22.0	30.0	72.0	10.0	3	2.50	45
10/3	10.0	9.2	22.0	30.0	72.0	10.0	3	3.00	45
12/0,5	12.0	11.0	26.0	36.0	83.0	12.0	3	0.50	45
12/1	12.0	11.0	26.0	36.0	83.0	12.0	3	1.00	45
12/1,5	12.0	11.0	26.0	36.0	83.0	12.0	3	1.50	45
12/2	12.0	11.0	26.0	36.0	83.0	12.0	3	2.00	45
12/2,5	12.0	11.0	26.0	36.0	83.0	12.0	3	2.50	45
12/3	12.0	11.0	26.0	36.0	83.0	12.0	3	3.00	45
12/4	12.0	11.0	26.0	36.0	83.0	12.0	3	4.00	45
16/1	16.0	15.0	36.0	42.0	92.0	16.0	3	1.00	45
16/1,5	16.0	15.0	36.0	42.0	92.0	16.0	3	1.50	45
16/2	16.0	15.0	36.0	42.0	92.0	16.0	3	2.00	45
16/2,5	16.0	15.0	36.0	42.0	92.0	16.0	3	2.50	45
16/3	16.0	15.0	36.0	42.0	92.0	16.0	3	3.00	45
16/4	16.0	15.0	36.0	42.0	92.0	16.0	3	4.00	45
20/1	20.0	19.0	41.0	52.0	104.0	20.0	3	1.00	45
20/2	20.0	19.0	41.0	52.0	104.0	20.0	3	2.00	45
20/3	20.0	19.0	41.0	52.0	104.0	20.0	3	3.00	45
20/4	20.0	19.0	41.0	52.0	104.0	20.0	3	4.00	45



Download Catalog Pages (PDF)

Dimension	Ø5			Ø6			Ø8			Ø10		
Infeed in mm	ae= 1xD	ae= 0.3xD	ae= 0.04xD	ae= 1xD	ae= 0.3xD	ae= 0.04xD	ae= 1xD	ae= 0.3xD	ae= 0.04xD	ae= 1xD	ae= 0.3xD	ae= 0.04xD
	ap= 1xD	ap= 1xD	ap= 0.04xD	ap= 1xD	ap= 1xD	ap= 0.04xD	ap= 1xD	ap= 1xD	ap= 0.04xD	ap= 1xD	ap= 1xD	ap= 0.04xD
Application												

Material	Strength (N/mm ²)	Feed (mm/Z)	Vc (m/min)												
N	NON-FERROUS														
1.1	ALUMINIUM alloyed	<500	500	0.055	0.07	0.08	0.06	0.08	0.09	0.08	0.1	0.11	0.09	0.12	0.13
1.2	ALUMINIUM alloyed	<600	480	0.055	0.07	0.08	0.06	0.08	0.09	0.08	0.1	0.11	0.09	0.12	0.13
2.1-2.3	ALUMINIUM casted	<600	450	0.05	0.065	0.075	0.055	0.075	0.085	0.075	0.09	0.1	0.08	0.11	0.12
3.1-3.3	COPPER alloyed	<650	200	0.045	0.06	0.07	0.05	0.07	0.08	0.07	0.085	0.095	0.075	0.1	0.11
4.1	MAGNESIUM alloyed	<250	500	0.055	0.07	0.08	0.06	0.08	0.09	0.08	0.1	0.11	0.09	0.12	0.13
5.1	PLASTICS Thermoplastic	<100	400	0.04	0.05	0.06	0.045	0.065	0.075	0.055	0.065	0.075	0.065	0.085	0.095
5.2	PLASTICS Duroplastic	<150	350	0.035	0.04	0.05	0.035	0.055	0.065	0.045	0.055	0.065	0.055	0.075	0.085

Dimension	Ø12			Ø16			Ø20		
Infeed in mm	ae= 1xD	ae= 0.3xD	ae= 0.04xD	ae= 1xD	ae= 0.3xD	ae= 0.04xD	ae= 1xD	ae= 0.3xD	ae= 0.04xD
	ap= 1xD	ap= 1xD	ap= 0.04xD	ap= 1xD	ap= 1xD	ap= 0.04xD	ap= 1xD	ap= 1xD	ap= 0.04xD
Application									

Material	Strength (N/mm ²)	Feed (mm/Z)	Vc (m/min)												
N	NON-FERROUS														
1.1	ALUMINIUM alloyed	<500	500	0.1	0.14	0.16	0.14	0.18	0.2	0.18	0.22	0.24			
1.2	ALUMINIUM alloyed	<600	480	0.1	0.14	0.16	0.14	0.18	0.2	0.18	0.22	0.24			
2.1-2.3	ALUMINIUM casted	<600	450	0.09	0.13	0.15	0.13	0.17	0.19	0.17	0.2	0.22			
3.1-3.3	COPPER alloyed	<650	200	0.085	0.12	0.14	0.12	0.16	0.18	0.16	0.18	0.2			
4.1	MAGNESIUM alloyed	<250	500	0.1	0.14	0.16	0.14	0.18	0.2	0.18	0.22	0.24			
5.1	PLASTICS Thermoplastic	<100	400	0.075	0.11	0.12	0.11	0.13	0.14	0.13	0.17	0.18			
5.2	PLASTICS Duroplastic	<150	350	0.065	0.1	0.11	0.1	0.12	0.13	0.12	0.16	0.17			

NOTE | By using multipass milling the maximum infeed (ae, ap) is 0.5x corner radius!

Cooling 

Tolerance h6

Coating AlphaSlide Rainbow

Strategy **HSC** **HPC** 

Application 

Features **HA** \neq 



- Defined clearance angle for ideal stabilization with high cutting depths
- Special helical pitch for smooth running and soft cut
- Extra large chip chambers for an extreme chip volume

- Long version for deeper cavities
- For roughing and finishing
- Multipass milling of 3D contours

- Radius tolerance $r \leq 1.5 \text{ mm}$: $\pm 0.003 \text{ mm}$
- Radius tolerance $r > 1.5 \text{ mm}$: $\pm 0.005 \text{ mm}$

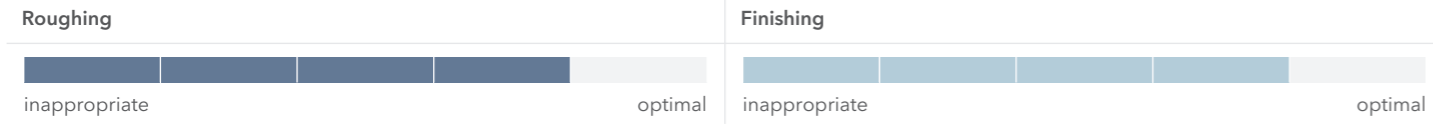
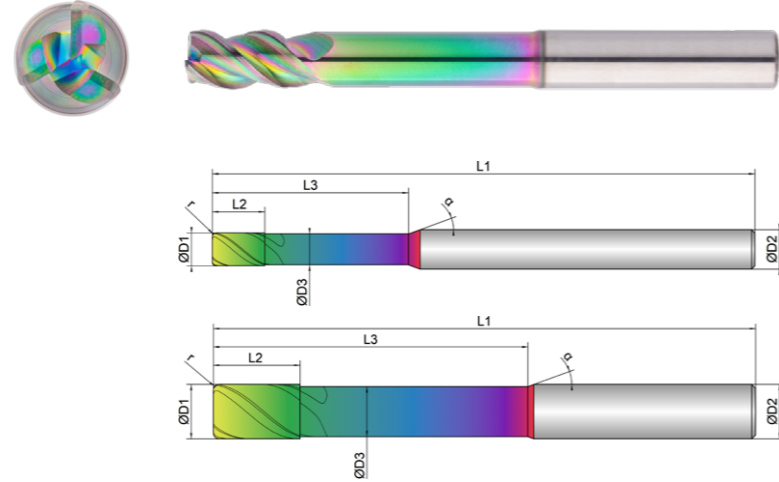

EXN1-M06-0013	D1 mm \varnothing	D3 mm \varnothing	L2 mm	L3 mm	L1 mm	D2 mm \varnothing	z #	r mm	α °
5/0,5	5.0	4.7	8.0	30.0	83.0	6.0	3	0.50	45
5/1	5.0	4.7	8.0	30.0	83.0	6.0	3	1.00	45
6/0,5	6.0	5.7	10.0	42.0	83.0	6.0	3	0.50	45
6/1	6.0	5.7	10.0	42.0	83.0	6.0	3	1.00	45
8/0,5	8.0	7.4	13.0	62.0	100.0	8.0	3	0.50	45
8/1	8.0	7.4	13.0	62.0	100.0	8.0	3	1.00	45
10/0,5	10.0	9.2	16.0	58.0	100.0	10.0	3	0.50	45
10/1	10.0	9.2	16.0	58.0	100.0	10.0	3	1.00	45
10/1,5	10.0	9.2	16.0	58.0	100.0	10.0	3	1.50	45
10/2	10.0	9.2	16.0	58.0	100.0	10.0	3	2.00	45
10/2,5	10.0	9.2	16.0	58.0	100.0	10.0	3	2.50	45

EXN1-M06-0013	D1 mm \varnothing	D3 mm \varnothing	L2 mm	L3 mm	L1 mm	D2 mm \varnothing	z #	r mm	α °
10/3	10.0	9.2	16.0	58.0	100.0	10.0	3	3.00	45
12/0,5	12.0	11.0	19.0	73.0	119.0	12.0	3	0.50	45
12/1	12.0	11.0	19.0	73.0	119.0	12.0	3	1.00	45
12/1,5	12.0	11.0	19.0	73.0	119.0	12.0	3	1.50	45
12/2	12.0	11.0	19.0	73.0	119.0	12.0	3	2.00	45
12/2,5	12.0	11.0	19.0	73.0	119.0	12.0	3	2.50	45
12/3	12.0	11.0	19.0	73.0	119.0	12.0	3	3.00	45
12/4	12.0	11.0	19.0	73.0	119.0	12.0	3	4.00	45
16/1	16.0	15.0	25.0	100.0	150.0	16.0	3	1.00	45
16/1,5	16.0	15.0	25.0	100.0	150.0	16.0	3	1.50	45
16/2	16.0	15.0	25.0	100.0	150.0	16.0	3	2.00	45
16/2,5	16.0	15.0	25.0	100.0	150.0	16.0	3	2.50	45
16/3	16.0	15.0	25.0	100.0	150.0	16.0	3	3.00	45
16/4	16.0	15.0	25.0	100.0	150.0	16.0	3	4.00	45
20/1	20.0	19.0	32.0	98.0	150.0	20.0	3	1.00	45
20/2	20.0	19.0	32.0	98.0	150.0	20.0	3	2.00	45
20/3	20.0	19.0	32.0	98.0	150.0	20.0	3	3.00	45
20/4	20.0	19.0	32.0	98.0	150.0	20.0	3	4.00	45



Download Catalog Pages (PDF)

Dimension	Ø5		Ø6		Ø8		Ø10		Ø12		Ø16	
Infeed in mm	ae= 0.3xD	ae= 0.04xD	ae= 0.3xD	ae= 0.04xD	ae= 0.3xD	ae= 0.04xD	ae= 0.3xD	ae= 0.04xD	ae= 0.3xD	ae= 0.04xD	ae= 0.3xD	ae= 0.04xD
Application	ap= 1xD	ap= 0.04xD	ap= 1xD	ap= 0.04xD	ap= 1xD	ap= 0.04xD	ap= 1xD	ap= 0.04xD	ap= 1xD	ap= 0.04xD	ap= 1xD	ap= 0.04xD







Material	Strength (N/mm ²)	Feed (mm/Z)	Vc (m/min)	fz	fz	fz	fz	fz	fz	fz	fz	fz	fz	fz	
N	NON-FERROUS														
1.1	ALUMINIUM alloyed	<500	280	0.065	0.075	0.065	0.075	0.075	0.085	0.09	0.1	0.1	0.12	0.12	0.14
1.2	ALUMINIUM alloyed	<600	260	0.065	0.075	0.065	0.075	0.075	0.085	0.09	0.1	0.1	0.12	0.12	0.14
2.1-2.3	ALUMINIUM casted	<600	240	0.055	0.065	0.055	0.065	0.065	0.075	0.08	0.09	0.09	0.11	0.11	0.13
3.1-3.3	COPPER alloyed	<650	120	0.045	0.055	0.045	0.055	0.055	0.065	0.07	0.08	0.08	0.1	0.1	0.12
4.1	MAGNESIUM alloyed	<250	280	0.065	0.075	0.065	0.075	0.075	0.085	0.09	0.1	0.1	0.12	0.12	0.14
5.1	PLASTICS Thermoplastic	<100	200	0.055	0.065	0.055	0.065	0.065	0.075	0.08	0.09	0.09	0.11	0.11	0.13
5.2	PLASTICS Duroplastic	<150	170	0.045	0.055	0.045	0.055	0.055	0.065	0.07	0.08	0.08	0.1	0.1	0.12

Dimension	Ø20	
Infeed in mm	ae= 0.3xD	ae= 0.04xD
Application	ap= 1xD	ap= 0.04xD

Material	Strength (N/mm ²)	Feed (mm/Z)	fz	fz	
N	NON-FERROUS				
1.1	ALUMINIUM alloyed	<500	280	0.14	0.16
1.2	ALUMINIUM alloyed	<600	260	0.14	0.16
2.1-2.3	ALUMINIUM casted	<600	240	0.13	0.15
3.1-3.3	COPPER alloyed	<650	120	0.12	0.14
4.1	MAGNESIUM alloyed	<250	280	0.14	0.16
5.1	PLASTICS Thermoplastic	<100	200	0.13	0.15
5.2	PLASTICS Duroplastic	<150	170	0.12	0.14

NOTE | By using multipass milling the maximum infeed (ae. ap) is 0.5x corner radius!

Cooling 
Tolerance f8
Coating AlphaSlide Rainbow

Strategy HSC 
Application 
Features HA  



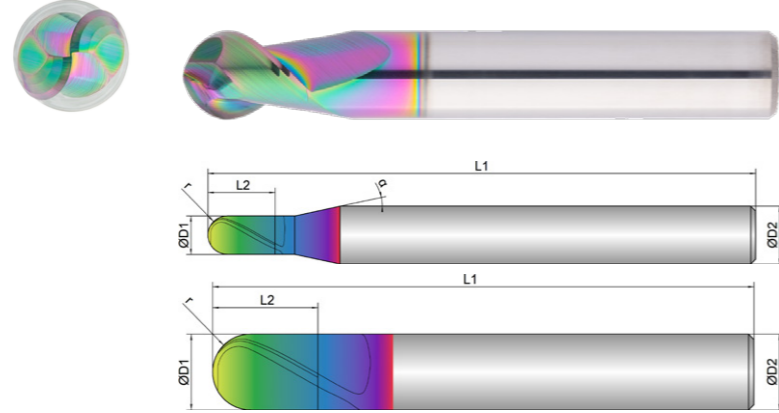



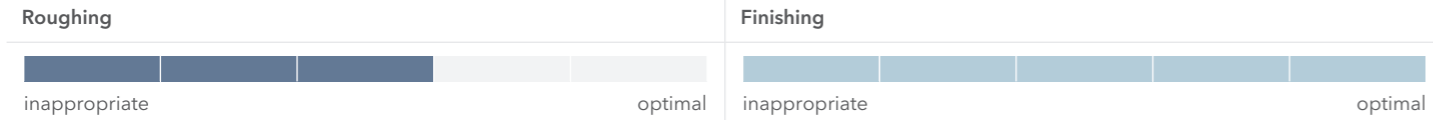

- Optimized face geometry for excellent surfaces
- Defined microlevel for support and stabilization
- Special chip chambers designed for optimal chip evacuation



- For use in HSC milling
- For roughing and finishing











- Radius tolerance $r \leq 2$ mm: ± 0.003 mm
- Radius tolerance $r > 2$ mm: ± 0.005 mm



EXN1-M08-0003	D1	L2	L1	D2	z	r		α
	 mm \varnothing	 mm	 mm	 mm \varnothing	 #	 mm		
0,5	0.5	1.0	55.0	6.0	2	0.25	45	12
1	1.0	2.0	55.0	6.0	2	0.50	45	12
2	2.0	4.0	55.0	6.0	2	1.00	45	12
3	3.0	6.0	55.0	6.0	2	1.50	45	12
4	4.0	7.0	55.0	6.0	2	2.00	45	12
5	5.0	8.0	55.0	6.0	2	2.50	45	12
6	6.0	10.0	55.0	6.0	2	3.00	45	0
8	8.0	12.0	63.0	8.0	2	4.00	45	0
10	10.0	14.0	72.0	10.0	2	5.00	45	0
12	12.0	16.0	74.0	12.0	2	6.00	45	0



Download Catalog Pages (PDF)

Dimension	Ø0.5	Ø1	Ø2	Ø3	Ø4	Ø5	Ø6	Ø8	Ø10	Ø12
Infeed in mm	ae= 0.05xD	ae= 0.05xD	ae= 0.05xD	ae= 0.05xD	ae= 0.05xD	ae= 0.05xD	ae= 0.05xD	ae= 0.05xD	ae= 0.05xD	ae= 0.05xD
	ap= 0.05xD	ap= 0.05xD	ap= 0.05xD	ap= 0.05xD	ap= 0.05xD	ap= 0.05xD	ap= 0.05xD	ap= 0.05xD	ap= 0.05xD	ap= 0.05xD
Application										

N	Material	Strength (N/mm ²)	Feed (mm/Z)	fz										
				fz	fz	fz	fz	fz	fz	fz	fz	fz	fz	
	NON-FERROUS		Vc (m/min)											
1.1	ALUMINIUM alloyed	<500	650	0.01	0.015	0.02	0.025	0.03	0.05	0.06	0.07	0.08	0.09	
1.2	ALUMINIUM alloyed	<600	620	0.01	0.015	0.02	0.025	0.03	0.05	0.06	0.07	0.08	0.09	
2.1-2.3	ALUMINIUM casted	<600	550	0.008	0.012	0.018	0.022	0.026	0.045	0.055	0.065	0.075	0.08	
3.1-3.3	COPPER alloyed	<650	280	0.006	0.008	0.015	0.018	0.022	0.04	0.05	0.06	0.07	0.07	
4.1	MAGNESIUM alloyed	<250	650	0.01	0.015	0.02	0.025	0.03	0.05	0.06	0.07	0.08	0.09	
5.1	PLASTICS Thermoplastic	<100	500	0.008	0.012	0.018	0.022	0.026	0.045	0.055	0.065	0.075	0.08	
5.2	PLASTICS Duroplastic	<150	400	0.006	0.008	0.015	0.018	0.022	0.04	0.05	0.06	0.07	0.07	

STILL CAN'T FIND A SUITABLE MILLING CUTTER?

No problem - simply customize an existing tool. Using our configurator for special milling cutters, you can customize existing tools to your needs in an instant or create your own tools based on predefined types.



WE WILL RESPOND TO ALL REQUESTS SUBMITTED VIA THE CONFIGURATOR WITHIN ONE WORKING DAY AT THE LATEST

Cooling

Tolerance f8

Coating AlphaSlide Rainbow

Strategy **HSC**

Application

Features **HA**

- Optimized face geometry for excellent surfaces
- Defined microlevel for support and stabilization
- Special chip chambers designed for optimal chip evacuation

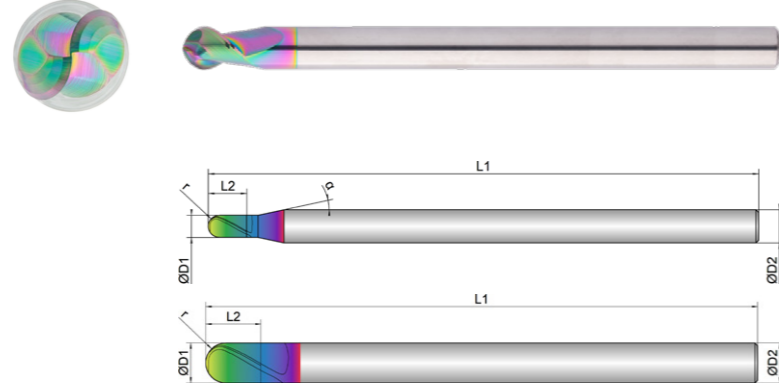

- Long version for deeper cavities
- For use in HSC milling
- For roughing and finishing

- Radius tolerance $r \leq 2 \text{ mm}$: $\pm 0.003 \text{ mm}$
- Radius tolerance $r > 2 \text{ mm}$: $\pm 0.005 \text{ mm}$

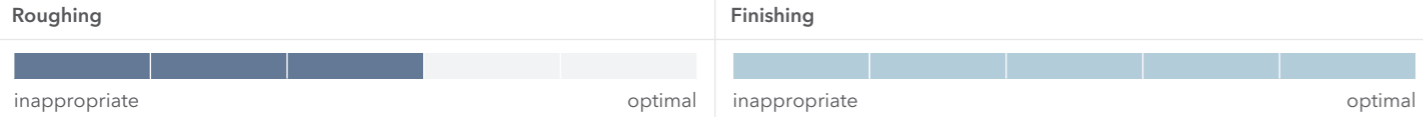

EXN1-M08-0013	D1 mm	L2 mm	L1 mm	D2 mm	z #	r mm		α
0,5	0.5	1.0	75.0	6.0	2	0.25	45	12
1	1.0	2.0	75.0	6.0	2	0.50	45	12
2	2.0	4.0	75.0	6.0	2	1.00	45	12
3	3.0	6.0	75.0	6.0	2	1.50	45	12
4	4.0	7.0	75.0	6.0	2	2.00	45	12
5	5.0	8.0	100.0	6.0	2	2.50	45	12
6	6.0	10.0	100.0	6.0	2	3.00	45	0
8	8.0	12.0	100.0	8.0	2	4.00	45	0
10	10.0	14.0	100.0	10.0	2	5.00	45	0
12	12.0	16.0	100.0	12.0	2	6.00	45	0



Download Catalog Pages (PDF)

Dimension	Ø0.5	Ø1	Ø2	Ø3	Ø4	Ø5	Ø6	Ø8	Ø10	Ø12
Infeed in mm	ae=0.05xD ap=0.05xD	ae=0.05xD ap=0.05xD	ae=0.05xD ap=0.05xD	ae=0.05xD ap=0.05xD	ae=0.05xD ap=0.05xD	ae=0.05xD ap=0.05xD	ae=0.05xD ap=0.05xD	ae=0.05xD ap=0.05xD	ae=0.05xD ap=0.05xD	ae=0.05xD ap=0.05xD
Application										

N	Material	Strength (N/mm ²)	Feed (mm/Z)	Feed (mm/Z)										
				fz	fz	fz	fz	fz	fz	fz	fz	fz	fz	
	NON-FERROUS		Vc (m/min)											
1.1	ALUMINIUM alloyed	<500	550	0.008	0.013	0.018	0.022	0.025	0.045	0.055	0.06	0.07	0.08	
1.2	ALUMINIUM alloyed	<600	525	0.008	0.013	0.018	0.022	0.025	0.045	0.055	0.06	0.07	0.08	
2.1-2.3	ALUMINIUM casted	<600	460	0.006	0.01	0.016	0.019	0.022	0.04	0.05	0.055	0.065	0.07	
3.1-3.3	COPPER alloyed	<650	240	0.005	0.007	0.014	0.016	0.018	0.035	0.045	0.05	0.06	0.06	
4.1	MAGNESIUM alloyed	<250	550	0.008	0.013	0.018	0.022	0.025	0.045	0.055	0.06	0.07	0.08	
5.1	PLASTICS Thermoplastic	<100	420	0.006	0.01	0.016	0.019	0.022	0.04	0.05	0.055	0.065	0.07	
5.2	PLASTICS Duroplastic	<150	340	0.005	0.007	0.014	0.016	0.018	0.035	0.045	0.05	0.06	0.06	

Cooling

Tolerance h6

Coating AlphaSlide Rainbow

Strategy **HSC**

Application

Features **HA**

- Four cutting edges to the center for the best dimensional accuracy at high material removal rates
- Defined microbevel and optimized face geometry for excellent surface quality

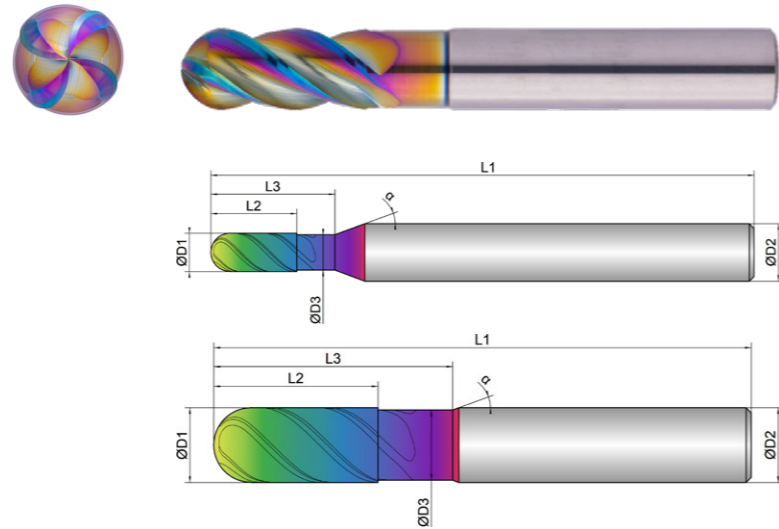

- For use in HSC milling
- For roughing and finishing

- Radius tolerance $r \leq 2$ mm: ± 0.003 mm
- Radius tolerance $r > 2$ mm: ± 0.005 mm



Download Catalog Pages (PDF)

Dimension	Ø3	Ø4	Ø5	Ø6	Ø8	Ø10	Ø12	Ø16
Infeed in mm	ae= 0.05xD	ae= 0.05xD	ae= 0.05xD	ae= 0.05xD	ae= 0.05xD	ae= 0.05xD	ae= 0.05xD	ae= 0.05xD
	ap= 0.05xD	ap= 0.05xD	ap= 0.05xD	ap= 0.05xD	ap= 0.05xD	ap= 0.05xD	ap= 0.05xD	ap= 0.05xD
Application								

N	Material	Strength (N/mm ²)	Feed (mm/Z)	Feed (mm/Z)							
				fz	fz	fz	fz	fz	fz	fz	fz
	NON-FERROUS		Vc (m/min)								
1.1	ALUMINIUM alloyed	<500	650	0.02	0.03	0.05	0.06	0.07	0.08	0.09	0.14
1.2	ALUMINIUM alloyed	<600	620	0.02	0.03	0.05	0.06	0.07	0.08	0.09	0.14
2.1-2.3	ALUMINIUM casted	<600	550	0.018	0.026	0.045	0.055	0.065	0.075	0.08	0.13
3.1-3.3	COPPER alloyed	<650	280	0.015	0.022	0.04	0.05	0.06	0.07	0.07	0.11
4.1	MAGNESIUM alloyed	<250	650	0.02	0.03	0.05	0.06	0.07	0.08	0.09	0.14
5.1	PLASTICS Thermoplastic	<100	500	0.018	0.026	0.045	0.055	0.065	0.075	0.08	0.12
5.2	PLASTICS Duroplastic	<150	400	0.015	0.022	0.04	0.05	0.06	0.07	0.07	0.11

Roughing

Finishing

EXN1-M08-0103	D1	D3	L2	L3	L1	D2	z	r	α
	mm	mm	mm	mm	mm	mm	#	mm	°
3	3.0	2.7	7.0	10.0	57.0	6.0	4	1.50	45
4	4.0	3.7	9.0	13.0	57.0	6.0	4	2.00	45
5	5.0	4.6	11.0	16.0	57.0	6.0	4	2.50	45
6	6.0	5.5	13.0	18.0	57.0	6.0	4	3.00	45
8	8.0	7.5	18.0	26.0	63.0	8.0	4	4.00	45
10	10.0	9.4	22.0	32.0	72.0	10.0	4	5.00	45
12	12.0	11.4	26.0	36.0	83.0	12.0	4	6.00	45
16	16.0	15.0	34.0	48.0	92.0	16.0	4	8.00	45

Cooling

Tolerance h6

Coating AlphaSlide Rainbow

Strategy **HSC**

Application

Features **HA**

- Four cutting edges to the center for the best dimensional accuracy at high material removal rates
- Defined microbevel and optimized face geometry for excellent surface quality

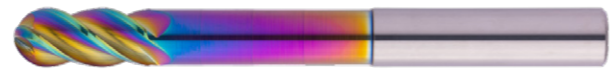
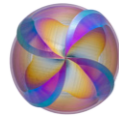

- Long version for deeper cavities
- For use in HSC milling
- For roughing and finishing

- Radius tolerance $r \leq 2$ mm: ± 0.003 mm
- Radius tolerance $r > 2$ mm: ± 0.005 mm

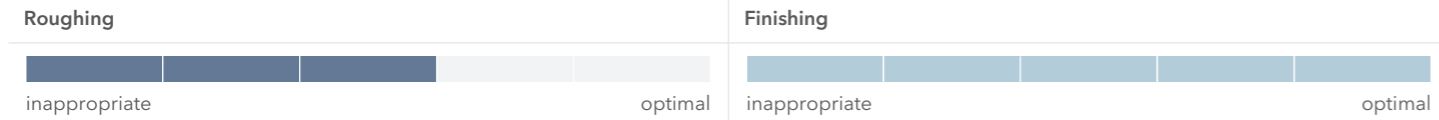
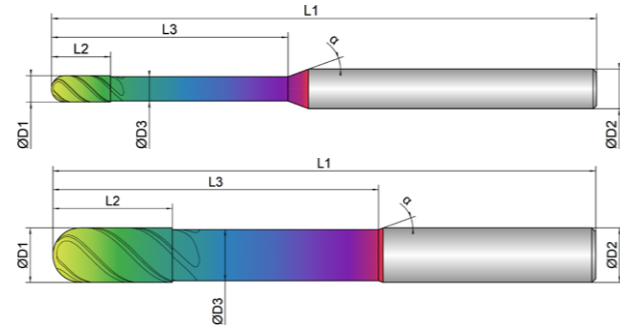

	D1	D3	L2	L3	L1	D2	z	r	α
EXN1-M08-0113									
	mm \varnothing	mm \varnothing	mm	mm	mm	mm \varnothing	#	mm	$^\circ$
3	3.0	2.7	7.0	32.0	83.0	6.0	4	1.50	45
4	4.0	3.7	9.0	36.0	83.0	6.0	4	2.00	45
5	5.0	4.6	11.0	40.0	83.0	6.0	4	2.50	45
6	6.0	5.5	13.0	44.0	83.0	6.0	4	3.00	45
8	8.0	7.5	18.0	54.0	100.0	8.0	4	4.00	45
10	10.0	9.4	22.0	60.0	100.0	10.0	4	5.00	45
12	12.0	11.4	26.0	60.0	100.0	12.0	4	6.00	45
16	16.0	15.0	34.0	92.0	150.0	16.0	4	8.00	45



Download Catalog Pages (PDF)

Dimension	Ø3	Ø4	Ø5	Ø6	Ø8	Ø10	Ø12	Ø16
Infeed in mm	ae=0.05xD ap=0.05xD	ae=0.05xD ap=0.05xD	ae=0.05xD ap=0.05xD	ae=0.05xD ap=0.05xD	ae=0.05xD ap=0.05xD	ae=0.05xD ap=0.05xD	ae=0.05xD ap=0.05xD	ae=0.05xD ap=0.05xD
Application								

N	Material	Strength (N/mm ²)	Feed (mm/Z)	Feed (mm/Z)							
				fz	fz	fz	fz	fz	fz	fz	fz
	NON-FERROUS		Vc (m/min)								
1.1	ALUMINIUM alloyed	<500	550	0.02	0.025	0.045	0.055	0.06	0.07	0.08	0.13
1.2	ALUMINIUM alloyed	<600	525	0.02	0.025	0.045	0.055	0.06	0.07	0.08	0.13
2.1-2.3	ALUMINIUM casted	<600	460	0.018	0.022	0.04	0.05	0.055	0.065	0.07	0.12
3.1-3.3	COPPER alloyed	<650	240	0.015	0.018	0.035	0.045	0.05	0.06	0.06	0.1
4.1	MAGNESIUM alloyed	<250	550	0.02	0.025	0.045	0.055	0.06	0.07	0.08	0.13
5.1	PLASTICS Thermoplastic	<100	420	0.018	0.022	0.04	0.05	0.055	0.065	0.07	0.11
5.2	PLASTICS Duroplastic	<150	340	0.015	0.018	0.035	0.045	0.05	0.06	0.06	0.1

Cooling

Tolerance d04

Coating AlphaSlide Rainbow

Strategy HSC

Application

Features HA

- Optimized face geometry for excellent surfaces
- Defined microlevel for support and stabilization
- Polished chip space for ideal chip evacuation

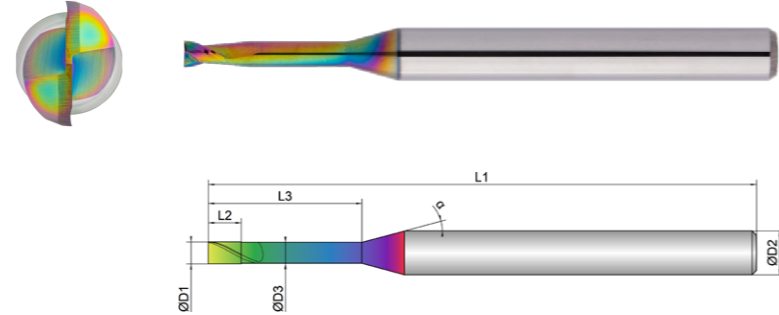

- Tolerance D1: -0.001/-0.006 mm
- Tolerance D3: 0/-0.02 mm

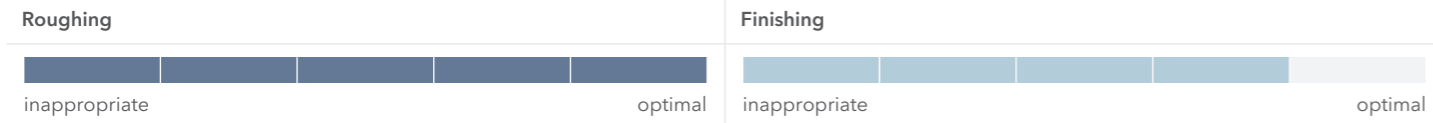

EXN1-M15-0003	D1 mm Ø	D3 mm Ø	L2 mm	L3 mm	L1 mm	D2 mm Ø	z #		α °
0,2X0,5	0.2	0.18	0.3	0.5	45.0	4.0	2	30	16
0,2X1	0.2	0.18	0.3	1.0	45.0	4.0	2	30	16
0,2X1,5	0.2	0.18	0.3	1.5	45.0	4.0	2	30	16
0,3X1	0.3	0.28	0.4	1.0	45.0	4.0	2	30	16
0,3X2	0.3	0.28	0.4	2.0	45.0	4.0	2	30	16
0,4X2	0.4	0.38	0.6	2.0	45.0	4.0	2	30	16
0,4X3	0.4	0.38	0.6	3.0	45.0	4.0	2	30	16
0,5X2	0.5	0.48	0.7	2.0	45.0	4.0	2	30	16
0,5X4	0.5	0.48	0.7	4.0	45.0	4.0	2	30	16
0,5X6	0.5	0.48	0.7	6.0	45.0	4.0	2	30	16
0,6X2	0.6	0.58	0.9	2.0	45.0	4.0	2	30	16
0,6X4	0.6	0.58	0.9	4.0	45.0	4.0	2	30	16
0,6X6	0.6	0.58	0.9	6.0	45.0	4.0	2	30	16
0,7X2	0.7	0.68	1.0	2.0	45.0	4.0	2	30	16

EXN1-M15-0003	D1 mm Ø	D3 mm Ø	L2 mm	L3 mm	L1 mm	D2 mm Ø	z #		α °
0,7X4	0.7	0.68	1.0	4.0	45.0	4.0	2	30	16
0,8X4	0.8	0.78	1.2	4.0	45.0	4.0	2	30	16
0,8X6	0.8	0.78	1.2	6.0	45.0	4.0	2	30	16
0,8X8	0.8	0.78	1.2	8.0	45.0	4.0	2	30	16
1X4	1.0	0.95	1.5	4.0	45.0	4.0	2	30	16
1X6	1.0	0.95	1.5	6.0	45.0	4.0	2	30	16
1X8	1.0	0.95	1.5	8.0	45.0	4.0	2	30	16
1X10	1.0	0.95	1.5	10.0	45.0	4.0	2	30	16
1X12	1.0	0.95	1.5	12.0	45.0	4.0	2	30	16
1X14	1.0	0.95	1.5	14.0	45.0	4.0	2	30	16
1X16	1.0	0.95	1.5	16.0	50.0	4.0	2	30	16
1X25	1.0	0.95	1.5	25.0	70.0	4.0	2	30	16
1,2X6	1.2	1.14	1.8	6.0	45.0	4.0	2	30	16
1,2X8	1.2	1.14	1.8	8.0	45.0	4.0	2	30	16
1,2X10	1.2	1.14	1.8	10.0	45.0	4.0	2	30	16
1,4X6	1.4	1.34	2.1	6.0	45.0	4.0	2	30	16
1,4X8	1.4	1.34	2.1	8.0	45.0	4.0	2	30	16
1,5X6	1.5	1.44	2.3	6.0	45.0	4.0	2	30	16
1,5X8	1.5	1.44	2.3	8.0	45.0	4.0	2	30	16
1,5X10	1.5	1.44	2.3	10.0	45.0	4.0	2	30	16
1,5X12	1.5	1.44	2.3	12.0	45.0	4.0	2	30	16
1,5X14	1.5	1.44	2.3	14.0	50.0	4.0	2	30	16
1,5X16	1.5	1.44	2.3	16.0	50.0	4.0	2	30	16
1,5X20	1.5	1.44	2.3	20.0	54.0	4.0	2	30	16
1,5X25	1.5	1.44	2.3	25.0	70.0	4.0	2	30	16

EXN1-M15-0003	D1	D3	L2	L3	L1	D2	z		α
							#		
1,6X6	1.6	1.51	2.4	6.0	45.0	4.0	2	30	16
1,6X10	1.6	1.51	2.4	10.0	45.0	4.0	2	30	16
1,8X6	1.8	1.71	2.7	6.0	45.0	4.0	2	30	16
1,8X8	1.8	1.71	2.7	8.0	45.0	4.0	2	30	16
1,8X10	1.8	1.71	2.7	10.0	45.0	4.0	2	30	16
2X6	2.0	1.91	3.0	6.0	45.0	4.0	2	30	16
2X8	2.0	1.91	3.0	8.0	45.0	4.0	2	30	16
2X10	2.0	1.91	3.0	10.0	45.0	4.0	2	30	16
2X12	2.0	1.91	3.0	12.0	45.0	4.0	2	30	16
2X14	2.0	1.91	3.0	14.0	50.0	4.0	2	30	16
2X16	2.0	1.91	3.0	16.0	50.0	4.0	2	30	16
2X20	2.0	1.91	3.0	20.0	54.0	4.0	2	30	16
2X25	2.0	1.91	3.0	25.0	60.0	4.0	2	30	16
2X30	2.0	1.91	3.0	30.0	70.0	4.0	2	30	16
2X35	2.0	1.91	3.0	35.0	80.0	4.0	2	30	16
2,5X8	2.5	2.41	3.7	8.0	45.0	4.0	2	30	16
2,5X12	2.5	2.41	3.7	12.0	45.0	4.0	2	30	16
2,5X16	2.5	2.41	3.7	16.0	50.0	4.0	2	30	16
2,5X20	2.5	2.41	3.7	20.0	54.0	4.0	2	30	16
2,5X25	2.5	2.41	3.7	25.0	60.0	4.0	2	30	16
2,5X30	2.5	2.41	3.7	30.0	70.0	4.0	2	30	16



Download Catalog Pages (PDF)

Dimension	Ø 0.2x0.5		Ø 0.2x1.5		Ø 0.3x1		Ø 0.3x2		Ø 0.4x2		Ø 0.4x3	
Infeed in mm	ae=1xD	ae=0.25xD	ae=1xD	ae=0.2xD	ae=1xD	ae=0.25xD	ae=1xD	ae=0.23xD	ae=1xD	ae=0.25xD	ae=1xD	ae=0.23xD
Application	ap=0.2xD	ap=L2 max	ap=0.18xD	ap=L2 max	ap=0.2xD	ap=L2 max	ap=0.18xD	ap=L2 max	ap=0.2xD	ap=L2 max	ap=0.18xD	ap=L2 max

N	Material	Strength (N/mm ²)	Feed (mm/Z)	Vc (m/min)											
				fz	fz	fz	fz	fz	fz	fz	fz	fz	fz	fz	fz
1.1	ALUMINIUM alloyed	<500	500	0.008	0.012	0.007	0.011	0.012	0.016	0.011	0.015	0.012	0.016	0.011	0.015
1.2	ALUMINIUM alloyed	<600	480	0.008	0.012	0.007	0.011	0.012	0.016	0.011	0.015	0.012	0.016	0.011	0.015
2.1-2.3	ALUMINIUM casted	<600	450	0.007	0.011	0.006	0.01	0.011	0.015	0.01	0.014	0.011	0.015	0.01	0.014
3.1-3.3	COPPER alloyed	<650	220	0.006	0.01	0.005	0.009	0.01	0.014	0.009	0.013	0.01	0.014	0.009	0.013
4.1	MAGNESIUM alloyed	<250	500	0.008	0.012	0.007	0.011	0.012	0.016	0.011	0.015	0.012	0.016	0.011	0.015
5.1	PLASTICS Thermoplastic	<100	400	0.007	0.011	0.006	0.01	0.011	0.015	0.01	0.014	0.011	0.015	0.01	0.014
5.2	PLASTICS Duroplastic	<150	350	0.006	0.01	0.005	0.009	0.01	0.014	0.009	0.013	0.01	0.014	0.009	0.013

Dimension	Ø 0.5x2		Ø 0.5x6		Ø 0.6x2		Ø 0.6x6		Ø 0.7x2		Ø 0.7x4	
Infeed in mm	ae=1xD	ae=0.25xD	ae=1xD	ae=0.12xD	ae=1xD	ae=0.25xD	ae=1xD	ae=0.12xD	ae=1xD	ae=0.25xD	ae=1xD	ae=0.23xD
Application	ap=0.2xD	ap=L2 max	ap=0.1xD	ap=L2 max	ap=0.2xD	ap=L2 max	ap=0.1xD	ap=L2 max	ap=0.2xD	ap=L2 max	ap=0.18xD	ap=L2 max

N	Material	Strength (N/mm ²)	Feed (mm/Z)	Vc (m/min)											
				fz	fz	fz	fz	fz	fz	fz	fz	fz	fz	fz	fz
1.1	ALUMINIUM alloyed	<500	500	0.016	0.02	0.013	0.017	0.016	0.02	0.013	0.017	0.016	0.02	0.015	0.018
1.2	ALUMINIUM alloyed	<600	480	0.016	0.02	0.013	0.017	0.016	0.02	0.013	0.017	0.016	0.02	0.015	0.018
2.1-2.3	ALUMINIUM casted	<600	450	0.015	0.018	0.012	0.015	0.015	0.018	0.012	0.015	0.015	0.018	0.014	0.016
3.1-3.3	COPPER alloyed	<650	220	0.014	0.016	0.011	0.013	0.014	0.016	0.011	0.013	0.014	0.016	0.013	0.014
4.1	MAGNESIUM alloyed	<250	500	0.016	0.02	0.013	0.017	0.016	0.02	0.013	0.017	0.016	0.02	0.015	0.018
5.1	PLASTICS Thermoplastic	<100	400	0.015	0.018	0.012	0.015	0.015	0.018	0.012	0.015	0.015	0.018	0.014	0.016
5.2	PLASTICS Duroplastic	<150	350	0.014	0.016	0.011	0.013	0.014	0.016	0.011	0.013	0.014	0.016	0.013	0.014

Dimension	Ø 0.8x4		Ø 0.8x8		Ø 1x4		Ø 1x25		Ø 1.2x6		Ø 1.2x10	
Infeed in mm	ae=1xD	ae=0.25xD	ae=1xD	ae=0.2xD	ae=1xD	ae=0.25xD	ae=1xD	ae=0.25xD	ae=1xD	ae=0.25xD	ae=1xD	ae=0.2xD
Application	ap=0.2xD	ap=L2 max	ap=0.16xD	ap=L2 max	ap=0.2xD	ap=L2 max	ap=0.02xD	ap=L2 max	ap=0.2xD	ap=L2 max	ap=0.16xD	ap=L2 max

N	Material	Strength (N/mm ²)	Feed (mm/Z)	Vc (m/min)											
				fz	fz	fz	fz	fz	fz	fz	fz	fz	fz	fz	fz
1.1	ALUMINIUM alloyed	<500	500	0.018	0.022	0.016	0.02	0.025	0.03	0.015	0.02	0.025	0.03	0.023	0.028
1.2	ALUMINIUM alloyed	<600	480	0.018	0.022	0.016	0.02	0.025	0.03	0.015	0.02	0.025	0.03	0.023	0.028
2.1-2.3	ALUMINIUM casted	<600	450	0.016	0.02	0.014	0.018	0.022	0.027	0.013	0.018	0.022	0.027	0.02	0.025
3.1-3.3	COPPER alloyed	<650	220	0.014	0.018	0.012	0.016	0.019	0.024	0.011	0.016	0.019	0.024	0.017	0.022
4.1	MAGNESIUM alloyed	<250	500	0.018	0.022	0.016	0.02	0.025	0.03	0.015	0.02	0.025	0.03	0.023	0.028
5.1	PLASTICS Thermoplastic	<100	400	0.016	0.02	0.014	0.018	0.022	0.027	0.013	0.018	0.022	0.027	0.02	0.025
5.2	PLASTICS Duroplastic	<150	350	0.014	0.018	0.012	0.016	0.019	0.024	0.011	0.016	0.019	0.024	0.017	0.022

NOTE | Values in the table are the shortest and the longest overhang length (L3) of each dimension; please calculate fz, ap and ae depending on the given values.

Dimension	Ø 1.4x6		Ø 1.4x8		Ø 1.5x6		Ø 1.5x25		Ø 1.6x6		Ø 1.6x10	
Infeed in mm	ae=1xD	ae=0.25xD	ae=1xD	ae=0.23xD	ae=1xD	ae=0.25xD	ae=1xD	ae=0.04xD	ae=1xD	ae=0.25xD	ae=1xD	ae=0.23xD
	ap=0.2xD	ap=L2 max	ap=0.18xD	ap=L2 max	ap=0.2xD	ap=L2 max	ap=0.03xD	ap=L2 max	ap=0.2xD	ap=L2 max	ap=0.18xD	ap=L2 max
Application												

Material	Strength (N/mm ²)	Feed (mm/Z)	Vc (m/min)	fz	fz	fz	fz	fz	fz	fz	fz	fz	fz	fz	
N NON-FERROUS															
1.1 ALUMINIUM alloyed	<500	500	500	0.025	0.03	0.024	0.028	0.025	0.03	0.018	0.023	0.03	0.035	0.028	0.033
1.2 ALUMINIUM alloyed	<600	480	480	0.025	0.03	0.024	0.028	0.025	0.03	0.018	0.023	0.03	0.035	0.028	0.033
2.1-2.3 ALUMINIUM casted	<600	450	450	0.022	0.027	0.021	0.025	0.022	0.027	0.015	0.02	0.027	0.031	0.025	0.03
3.1-3.3 COPPER alloyed	<650	220	220	0.019	0.024	0.018	0.022	0.019	0.024	0.012	0.017	0.024	0.027	0.022	0.027
4.1 MAGNESIUM alloyed	<250	500	500	0.025	0.03	0.024	0.028	0.025	0.03	0.018	0.023	0.03	0.035	0.028	0.033
5.1 PLASTICS Thermoplastic	<100	400	400	0.022	0.027	0.021	0.025	0.022	0.027	0.015	0.02	0.027	0.031	0.025	0.03
5.2 PLASTICS Duroplastic	<150	350	350	0.019	0.024	0.018	0.022	0.019	0.024	0.012	0.017	0.024	0.027	0.022	0.027

Dimension	Ø 1.8x6		Ø 1.8x10		Ø 2x6		Ø 2x35		Ø 2.5x8		Ø 2.5x30	
Infeed in mm	ae=1xD	ae=0.25xD	ae=1xD	ae=0.23xD	ae=1xD	ae=0.25xD	ae=1xD	ae=0.025xD	ae=1xD	ae=0.25xD	ae=1xD	ae=0.08xD
	ap=0.2xD	ap=L2 max	ap=0.18xD	ap=L2 max	ap=0.2xD	ap=L2 max	ap=0.02xD	ap=L2 max	ap=0.2xD	ap=L2 max	ap=0.06xD	ap=L2 max
Application												

Material	Strength (N/mm ²)	Feed (mm/Z)	Vc (m/min)	fz	fz	fz	fz	fz	fz	fz	fz	fz	fz	fz	
N NON-FERROUS															
1.1 ALUMINIUM alloyed	<500	500	500	0.03	0.035	0.028	0.033	0.03	0.035	0.018	0.023	0.035	0.04	0.023	0.028
1.2 ALUMINIUM alloyed	<600	480	480	0.03	0.035	0.028	0.033	0.03	0.035	0.018	0.023	0.035	0.04	0.023	0.028
2.1-2.3 ALUMINIUM casted	<600	450	450	0.027	0.031	0.025	0.03	0.027	0.031	0.015	0.02	0.03	0.035	0.02	0.025
3.1-3.3 COPPER alloyed	<650	220	220	0.024	0.027	0.022	0.027	0.024	0.027	0.012	0.017	0.025	0.03	0.017	0.022
4.1 MAGNESIUM alloyed	<250	500	500	0.03	0.035	0.028	0.033	0.03	0.035	0.018	0.023	0.035	0.04	0.023	0.028
5.1 PLASTICS Thermoplastic	<100	400	400	0.027	0.031	0.025	0.03	0.027	0.031	0.015	0.02	0.03	0.035	0.02	0.025
5.2 PLASTICS Duroplastic	<150	350	350	0.024	0.027	0.022	0.027	0.024	0.027	0.012	0.017	0.025	0.03	0.017	0.022

NOTE | Values in the table are the shortest and the longest overhang length (L3) of each dimension; please calculate fz, ap and ae depending on the given values.







STILL CAN'T FIND A SUITABLE MILLING CUTTER?

No problem - simply customize an existing tool. Using our configurator for special milling cutters, you can customize existing tools to your needs in an instant or create your own tools based on predefined types.

WE WILL RESPOND TO ALL REQUESTS SUBMITTED VIA THE CONFIGURATOR WITHIN ONE WORKING DAY AT THE LATEST



Cooling 
Tolerance d04
Coating AlphaSlide Rainbow



Strategy HSC 
Application 
Features HA      

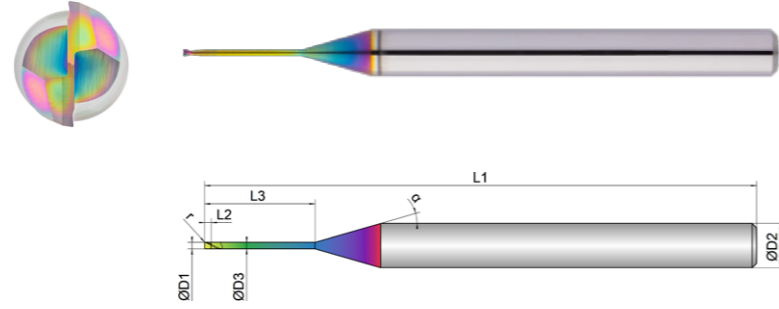









- Optimized face geometry for excellent surfaces and highest dimensional accuracy
- Defined microbevel for support and stabilization
- Polished chip space for ideal chip evacuation







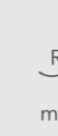
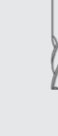





- Multipass milling of 3D contours

- Tolerance D1: -0.001/-0.006 mm
- Tolerance D3: 0/-0.02 mm
- Radius tolerance r: 0/-0.003 mm (measured from 0-90°)

Roughing  **Finishing** 

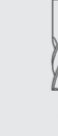
EXN1-M16-0023	D1 mm 	D3 mm 	L2 mm 	L3 mm 	L1 mm 	D2 mm 	z # 	r mm 		α ° 
0,2X0,5	0.2	0.18	0.2	0.5	50.0	4.0	2	0.05	30	16
0,2X1	0.2	0.18	0.2	1.0	50.0	4.0	2	0.05	30	16
0,2X2	0.2	0.18	0.2	2.0	50.0	4.0	2	0.05	30	16
0,2X3	0.2	0.18	0.2	3.0	50.0	4.0	2	0.05	30	16
0,3X1	0.3	0.28	0.3	1.0	50.0	4.0	2	0.05	30	16
0,3X2	0.3	0.28	0.3	2.0	50.0	4.0	2	0.05	30	16
0,3X3	0.3	0.28	0.3	3.0	50.0	4.0	2	0.05	30	16
0,3X4	0.3	0.28	0.3	4.0	50.0	4.0	2	0.05	30	16
0,3X6	0.3	0.28	0.3	6.0	50.0	4.0	2	0.05	30	16
0,4X1	0.4	0.38	0.4	1.0	50.0	4.0	2	0.05	30	16
0,4X2	0.4	0.38	0.4	2.0	50.0	4.0	2	0.05	30	16

EXN1-M16-0023	D1 mm 	D3 mm 	L2 mm 	L3 mm 	L1 mm 	D2 mm 	z # 	r mm 		α ° 
0,4X3	0.4	0.38	0.4	3.0	50.0	4.0	2	0.05	30	16
0,4X4	0.4	0.38	0.4	4.0	50.0	4.0	2	0.05	30	16
0,4X6	0.4	0.38	0.4	6.0	50.0	4.0	2	0.05	30	16
0,4X8	0.4	0.38	0.4	8.0	50.0	4.0	2	0.05	30	16
0,5X1	0.5	0.48	0.5	1.0	50.0	4.0	2	0.05	30	16
0,5X2	0.5	0.48	0.5	2.0	50.0	4.0	2	0.05	30	16
0,5X3	0.5	0.48	0.5	3.0	50.0	4.0	2	0.05	30	16
0,5X4	0.5	0.48	0.5	4.0	50.0	4.0	2	0.05	30	16
0,5X6	0.5	0.48	0.5	6.0	50.0	4.0	2	0.05	30	16
0,5X8	0.5	0.48	0.5	8.0	50.0	4.0	2	0.05	30	16
0,5X10	0.5	0.48	0.5	10.0	50.0	4.0	2	0.05	30	16
0,6X3	0.6	0.58	0.6	3.0	50.0	4.0	2	0.05	30	16
0,6X4	0.6	0.58	0.6	4.0	50.0	4.0	2	0.05	30	16
0,6X6	0.6	0.58	0.6	6.0	50.0	4.0	2	0.05	30	16
0,6X8	0.6	0.58	0.6	8.0	50.0	4.0	2	0.05	30	16
0,6X10	0.6	0.58	0.6	10.0	50.0	4.0	2	0.05	30	16



Download Catalog Pages (PDF)

Dimension	Ø 0.2x0.5			Ø 0.2x3			Ø 0.3x1			Ø 0.3x6		
Infeed in mm	ae=1xD	ae=0.25xD	ae=0.1xD	ae=1xD	ae=0.05xD	ae=0.05xD	ae=1xD	ae=0.25xD	ae=0.1xD	ae=1xD	ae=0.03xD	ae=0.01xD
Application	ap=0.2xD	ap=L2 max	ap=0.1xD	ap=0.06xD	ap=L2 max	ap=0.05xD	ap=0.2xD	ap=L2 max	ap=0.1xD	ap=0.02xD	ap=L2 max	ap=0.01xD
Feed (mm/Z)	fz	fz	fz	fz	fz	fz	fz	fz	fz	fz	fz	fz

N	Material	Strength (N/mm²)	Feed (mm/Z)	Vc (m/min)	fz	fz	fz	fz	fz	fz	fz	fz	fz	fz		
NON-FERROUS																
1.1	ALUMINIUM alloyed	<500	500	500	0.008	0.012	0.014	0.005	0.007	0.009	0.008	0.012	0.014	0.005	0.007	0.009
1.2	ALUMINIUM alloyed	<600	480	480	0.008	0.012	0.014	0.005	0.007	0.009	0.008	0.012	0.014	0.005	0.007	0.009
2.1-2.3	ALUMINIUM casted	<600	450	450	0.007	0.011	0.013	0.004	0.006	0.008	0.007	0.011	0.013	0.004	0.006	0.008
3.1-3.3	COPPER alloyed	<650	220	220	0.006	0.01	0.012	0.003	0.005	0.007	0.006	0.01	0.012	0.003	0.005	0.007
4.1	MAGNESIUM alloyed	<250	500	500	0.008	0.012	0.014	0.005	0.007	0.009	0.008	0.012	0.014	0.005	0.007	0.009
5.1	PLASTICS Thermoplastic	<100	400	400	0.007	0.011	0.013	0.004	0.006	0.008	0.007	0.011	0.013	0.004	0.006	0.008
5.2	PLASTICS Duroplastic	<150	350	350	0.006	0.01	0.012	0.003	0.005	0.007	0.006	0.01	0.012	0.003	0.005	0.007

Dimension	Ø 0.4x1			Ø 0.4x8			Ø 0.5x1			Ø 0.5x10		
Infeed in mm	ae=1xD	ae=0.25xD	ae=0.1xD	ae=1xD	ae=0.03xD	ae=0.1xD	ae=1xD	ae=0.25xD	ae=0.1xD	ae=1xD	ae=0.03xD	ae=0.1xD
Application	ap=0.2xD	ap=L2 max	ap=0.1xD	ap=0.02xD	ap=L2 max	ap=0.01xD	ap=0.2xD	ap=L2 max	ap=0.1xD	ap=0.02xD	ap=L2 max	ap=0.01xD
Feed (mm/Z)	fz	fz	fz	fz	fz	fz	fz	fz	fz	fz	fz	fz

N	Material	Strength (N/mm²)	Feed (mm/Z)	Vc (m/min)	fz	fz	fz	fz	fz	fz	fz	fz	fz	fz		
NON-FERROUS																
1.1	ALUMINIUM alloyed	<500	500	500	0.012	0.016	0.018	0.005	0.007	0.009	0.016	0.02	0.022	0.009	0.013	0.015
1.2	ALUMINIUM alloyed	<600	480	480	0.012	0.016	0.018	0.005	0.007	0.009	0.016	0.02	0.022	0.009	0.013	0.015
2.1-2.3	ALUMINIUM casted	<600	450	450	0.011	0.015	0.017	0.004	0.006	0.008	0.015	0.018	0.021	0.008	0.012	0.014
3.1-3.3	COPPER alloyed	<650	220	220	0.01	0.014	0.016	0.003	0.005	0.007	0.014	0.016	0.02	0.007	0.011	0.013
4.1	MAGNESIUM alloyed	<250	500	500	0.012	0.016	0.018	0.005	0.007	0.009	0.016	0.02	0.022	0.009	0.013	0.015
5.1	PLASTICS Thermoplastic	<100	400	400	0.011	0.015	0.017	0.004	0.006	0.008	0.015	0.018	0.021	0.008	0.012	0.014
5.2	PLASTICS Duroplastic	<150	350	350	0.01	0.014	0.016	0.003	0.005	0.007	0.014	0.016	0.02	0.007	0.011	0.013

Dimension	Ø 0.6x3			Ø 0.6x10		
Infeed in mm	ae=1xD	ae=0.25xD	ae=0.1xD	ae=1xD	ae=0.04xD	ae=0.015xD
Application	ap=0.2xD	ap=L2 max	ap=0.1xD	ap=0.03xD	ap=L2 max	ap=0.015xD
Feed (mm/Z)	fz	fz	fz	fz	fz	fz

N	Material	Strength (N/mm²)	Feed (mm/Z)	Vc (m/min)	fz	fz	fz	fz	fz	fz
NON-FERROUS										
1.1	ALUMINIUM alloyed	<500	500	500	0.016	0.02	0.022	0.012	0.015	0.017
1.2	ALUMINIUM alloyed	<600	480	480	0.016	0.02	0.022	0.012	0.015	0.017
2.1-2.3	ALUMINIUM casted	<600	450	450	0.015	0.018	0.021	0.011	0.014	0.016
3.1-3.3	COPPER alloyed	<650	220	220	0.014	0.016	0.02	0.01	0.013	0.015
4.1	MAGNESIUM alloyed	<250	500	500	0.016	0.02	0.022	0.012	0.015	0.017
5.1	PLASTICS Thermoplastic	<100	400	400	0.015	0.018	0.021	0.011	0.014	0.016
5.2	PLASTICS Duroplastic	<150	350	350	0.014	0.016	0.02	0.01	0.013	0.015

NOTE | Values in the table are the shortest and the longest overhang length (L3) of each dimension; please calculate fz, ap and ae depending on the given values.

ae/ap(max)=0.5x corner radius!



STILL CAN'T FIND A SUITABLE MILLING CUTTER?

No problem - simply customize an existing tool. Using our configurator for special milling cutters, you can customize existing tools to your needs in an instant or create your own tools based on predefined types.

WE WILL RESPOND TO ALL REQUESTS SUBMITTED VIA THE CONFIGURATOR WITHIN ONE WORKING DAY AT THE LATEST



Cooling

Tolerance d04

Coating AlphaSlide Rainbow

Strategy **HSC**

Application

Features **HA**

- Optimized face geometry for excellent surfaces and highest dimensional accuracy
- Defined microbevel for support and stabilization
- Polished chip space for ideal chip evacuation

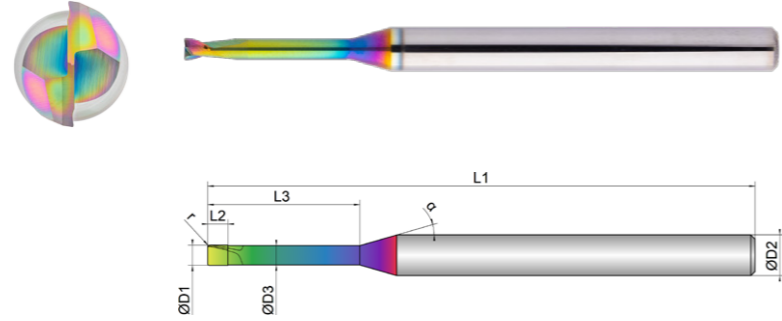

- Multipass milling of 3D contours

- Tolerance D1: -0.001/-0.006 mm
- Tolerance D3: 0/-0.02 mm
- Radius tolerance r: 0/-0.003 mm (measured from 0-90°)

Roughing **Finishing**

inappropriate optimal inappropriate optimal

EXN1-M16-0063	D1 mm Ø	D3 mm Ø	L2 mm	L3 mm	L1 mm	D2 mm Ø	z #	r mm		α °
0,4X1	0.4	0.38	0.4	1.0	50.0	4.0	2	0.10	30	16
0,4X2	0.4	0.38	0.4	2.0	50.0	4.0	2	0.10	30	16
0,4X3	0.4	0.38	0.4	3.0	50.0	4.0	2	0.10	30	16
0,4X4	0.4	0.38	0.4	4.0	50.0	4.0	2	0.10	30	16
0,4X6	0.4	0.38	0.4	6.0	50.0	4.0	2	0.10	30	16
0,4X8	0.4	0.38	0.4	8.0	50.0	4.0	2	0.10	30	16
0,5X1	0.5	0.48	0.5	1.0	50.0	4.0	2	0.10	30	16
0,5X2	0.5	0.48	0.5	2.0	50.0	4.0	2	0.10	30	16
0,5X3	0.5	0.48	0.5	3.0	50.0	4.0	2	0.10	30	16
0,5X4	0.5	0.48	0.5	4.0	50.0	4.0	2	0.10	30	16
0,5X6	0.5	0.48	0.5	6.0	50.0	4.0	2	0.10	30	16
0,5X8	0.5	0.48	0.5	8.0	50.0	4.0	2	0.10	30	16
0,5X10	0.5	0.48	0.5	10.0	50.0	4.0	2	0.10	30	16

EXN1-M16-0063	D1 mm Ø	D3 mm Ø	L2 mm	L3 mm	L1 mm	D2 mm Ø	z #	r mm		α °
0,6X3	0.6	0.58	0.6	3.0	50.0	4.0	2	0.10	30	16
0,6X4	0.6	0.58	0.6	4.0	50.0	4.0	2	0.10	30	16
0,6X6	0.6	0.58	0.6	6.0	50.0	4.0	2	0.10	30	16
0,6X8	0.6	0.58	0.6	8.0	50.0	4.0	2	0.10	30	16
0,6X10	0.6	0.58	0.6	10.0	50.0	4.0	2	0.10	30	16
0,8X2	0.8	0.78	0.8	2.0	50.0	4.0	2	0.10	30	16
0,8X4	0.8	0.78	0.8	4.0	50.0	4.0	2	0.10	30	16
0,8X6	0.8	0.78	0.8	6.0	50.0	4.0	2	0.10	30	16
0,8X8	0.8	0.78	0.8	8.0	50.0	4.0	2	0.10	30	16
0,8X10	0.8	0.78	0.8	10.0	50.0	4.0	2	0.10	30	16
0,8X12	0.8	0.78	0.8	12.0	50.0	4.0	2	0.10	30	16
1X2	1.0	0.95	1.0	2.0	50.0	4.0	2	0.10	30	16
1X3	1.0	0.95	1.0	3.0	50.0	4.0	2	0.10	30	16
1X4	1.0	0.95	1.0	4.0	50.0	4.0	2	0.10	30	16
1X5	1.0	0.95	1.0	5.0	50.0	4.0	2	0.10	30	16
1X6	1.0	0.95	1.0	6.0	50.0	4.0	2	0.10	30	16
1X8	1.0	0.95	1.0	8.0	50.0	4.0	2	0.10	30	16
1X10	1.0	0.95	1.0	10.0	50.0	4.0	2	0.10	30	16
1X12	1.0	0.95	1.0	12.0	54.0	4.0	2	0.10	30	16
1X15	1.0	0.95	1.0	15.0	60.0	4.0	2	0.10	30	16
1X20	1.0	0.95	1.0	20.0	60.0	4.0	2	0.10	30	16
1X25	1.0	0.95	1.0	25.0	70.0	4.0	2	0.10	30	16
1X30	1.0	0.95	1.0	30.0	70.0	4.0	2	0.10	30	16
1,2X5	1.2	1.14	1.2	5.0	50.0	4.0	2	0.10	30	16
1,2X10	1.2	1.14	1.2	10.0	50.0	4.0	2	0.10	30	16
1,2X15	1.2	1.14	1.2	15.0	54.0	4.0	2	0.10	30	16
1,2X20	1.2	1.14	1.2	20.0	60.0	4.0	2	0.10	30	16

EXN1-M16-0063	D1	D3	L2	L3	L1	D2	z	r	α	
	mm ∅	mm ∅	mm	mm	mm	mm ∅	#	mm	°	°
1,5X4	1.5	1.44	1.5	4.0	50.0	4.0	2	0.10	30	16
1,5X6	1.5	1.44	1.5	6.0	50.0	4.0	2	0.10	30	16
1,5X8	1.5	1.44	1.5	8.0	50.0	4.0	2	0.10	30	16
1,5X10	1.5	1.44	1.5	10.0	50.0	4.0	2	0.10	30	16
1,5X12	1.5	1.44	1.5	12.0	54.0	4.0	2	0.10	30	16
1,5X15	1.5	1.44	1.5	15.0	54.0	4.0	2	0.10	30	16
1,5X20	1.5	1.44	1.5	20.0	60.0	4.0	2	0.10	30	16
1,5X25	1.5	1.44	1.5	25.0	60.0	4.0	2	0.10	30	16
1,5X30	1.5	1.44	1.5	30.0	70.0	4.0	2	0.10	30	16
1,8X8	1.8	1.74	1.8	8.0	50.0	4.0	2	0.10	30	16
1,8X10	1.8	1.74	1.8	10.0	50.0	4.0	2	0.10	30	16
1,8X15	1.8	1.74	1.8	15.0	50.0	4.0	2	0.10	30	16
1,8X20	1.8	1.74	1.8	20.0	54.0	4.0	2	0.10	30	16
2X4	2.0	1.91	2.0	4.0	50.0	4.0	2	0.10	30	16
2X6	2.0	1.91	2.0	6.0	50.0	4.0	2	0.10	30	16
2X8	2.0	1.91	2.0	8.0	50.0	4.0	2	0.10	30	16
2X10	2.0	1.91	2.0	10.0	50.0	4.0	2	0.10	30	16
2X12	2.0	1.91	2.0	12.0	54.0	4.0	2	0.10	30	16
2X15	2.0	1.91	2.0	15.0	54.0	4.0	2	0.10	30	16
2X20	2.0	1.91	2.0	20.0	60.0	4.0	2	0.10	30	16
2X25	2.0	1.91	2.0	25.0	70.0	4.0	2	0.10	30	16
2X30	2.0	1.91	2.0	30.0	70.0	4.0	2	0.10	30	16
2X35	2.0	1.91	2.0	35.0	80.0	4.0	2	0.10	30	16
2X40	2.0	1.91	2.0	40.0	80.0	4.0	2	0.10	30	16



Download Catalog Pages (PDF)

Material	Strength (N/mm ²)	Feed (mm/Z)	Dimension												
			∅ 0.4x1			∅ 0.4x8			∅ 0.5x1			∅ 0.5x10			
N	NON-FERROUS	Vc (m/min)	fz	fz	fz	fz	fz	fz	fz	fz	fz	fz	fz	fz	
1.1	ALUMINIUM alloyed	<500	500	0.012	0.016	0.018	0.005	0.007	0.009	0.016	0.02	0.022	0.009	0.013	0.015
1.2	ALUMINIUM alloyed	<600	480	0.012	0.016	0.018	0.005	0.007	0.009	0.016	0.02	0.022	0.009	0.013	0.015
2.1-2.3	ALUMINIUM casted	<600	450	0.011	0.015	0.017	0.004	0.006	0.008	0.015	0.018	0.021	0.008	0.012	0.014
3.1-3.3	COPPER alloyed	<650	220	0.01	0.014	0.016	0.003	0.005	0.007	0.014	0.016	0.02	0.007	0.011	0.013
4.1	MAGNESIUM alloyed	<250	500	0.012	0.016	0.018	0.005	0.007	0.009	0.016	0.02	0.022	0.009	0.013	0.015
5.1	PLASTICS Thermoplastic	<100	400	0.011	0.015	0.017	0.004	0.006	0.008	0.015	0.018	0.021	0.008	0.012	0.014
5.2	PLASTICS Duroplastic	<150	350	0.01	0.014	0.016	0.003	0.005	0.007	0.014	0.016	0.02	0.007	0.011	0.013

Material	Strength (N/mm ²)	Feed (mm/Z)	Dimension												
			∅ 0.6x3			∅ 0.6x10			∅ 0.8x2			∅ 0.8x12			
N	NON-FERROUS	Vc (m/min)	fz	fz	fz	fz	fz	fz	fz	fz	fz	fz	fz	fz	
1.1	ALUMINIUM alloyed	<500	500	0.016	0.02	0.022	0.012	0.015	0.017	0.016	0.02	0.022	0.012	0.015	0.017
1.2	ALUMINIUM alloyed	<600	480	0.016	0.02	0.022	0.012	0.015	0.017	0.016	0.02	0.022	0.012	0.015	0.017
2.1-2.3	ALUMINIUM casted	<600	450	0.015	0.018	0.021	0.011	0.014	0.016	0.015	0.018	0.021	0.011	0.014	0.016
3.1-3.3	COPPER alloyed	<650	220	0.014	0.016	0.02	0.01	0.013	0.015	0.014	0.016	0.02	0.01	0.013	0.015
4.1	MAGNESIUM alloyed	<250	500	0.016	0.02	0.022	0.012	0.015	0.017	0.016	0.02	0.022	0.012	0.015	0.017
5.1	PLASTICS Thermoplastic	<100	400	0.015	0.018	0.021	0.011	0.014	0.016	0.015	0.018	0.021	0.011	0.014	0.016
5.2	PLASTICS Duroplastic	<150	350	0.014	0.016	0.02	0.01	0.013	0.015	0.014	0.016	0.02	0.01	0.013	0.015

Material	Strength (N/mm ²)	Feed (mm/Z)	Dimension												
			∅ 1x2			∅ 1x30			∅ 1.2x5			∅ 1.2x20			
N	NON-FERROUS	Vc (m/min)	fz	fz	fz	fz	fz	fz	fz	fz	fz	fz	fz	fz	
1.1	ALUMINIUM alloyed	<500	500	0.025	0.03	0.035	0.01	0.015	0.02	0.025	0.03	0.035	0.02	0.025	0.03
1.2	ALUMINIUM alloyed	<600	480	0.025	0.03	0.035	0.01	0.015	0.02	0.025	0.03	0.035	0.02	0.025	0.03
2.1-2.3	ALUMINIUM casted	<600	450	0.022	0.027	0.032	0.008	0.013	0.017	0.022	0.027	0.032	0.017	0.022	0.027
3.1-3.3	COPPER alloyed	<650	220	0.019	0.024	0.029	0.006	0.011	0.014	0.019	0.024	0.029	0.014	0.019	0.024
4.1	MAGNESIUM alloyed	<250	500	0.025	0.03	0.035	0.01	0.015	0.02	0.025	0.03	0.035	0.02	0.025	0.03
5.1	PLASTICS Thermoplastic	<100	400	0.022	0.027	0.032	0.008	0.013	0.017	0.022	0.027	0.032	0.017	0.022	0.027
5.2	PLASTICS Duroplastic	<150	350	0.019	0.024	0.029	0.006	0.011	0.014	0.019	0.024	0.029	0.014	0.019	0.024

NOTE | Values in the table are the shortest and the longest overhang length (L3) of each dimension; please calculate fz, ap and ae depending on the given values.
 ae/ap(max) = 0.5x corner radius!

Dimension	Ø 1.5x4			Ø 1.5x30			Ø 1.8x8			Ø 1.8x20		
Infeed in mm	ae= 1xD	ae= 0.25xD	ae= 0.1xD	ae= 1xD	ae= 0.03xD	ae= 0.01xD	ae= 1xD	ae= 0.25xD	ae= 0.1xD	ae= 1xD	ae= 0.13xD	ae= 0.05xD
Application	ap= 0.2xD	ap= L2 max	ae= 0.1xD	ap= 0.02xD	ap= L2 max	ae= 0.01xD	ap= 0.2xD	ap= L2 max	ae= 0.1xD	ap= 0.1xD	ap= L2 max	ae= 0.05xD
Application												

Material	Strength (N/mm ²)	Feed (mm/Z)	Vc (m/min)	fz	fz	fz	fz	fz	fz	fz	fz	fz	fz	fz	
N	NON-FERROUS														
1.1	ALUMINIUM alloyed	<500	500	0.025	0.03	0.035	0.015	0.02	0.025	0.03	0.035	0.04	0.025	0.03	0.035
1.2	ALUMINIUM alloyed	<600	480	0.025	0.03	0.035	0.015	0.02	0.025	0.03	0.035	0.04	0.025	0.03	0.035
2.1-2.3	ALUMINIUM casted	<600	450	0.022	0.027	0.032	0.013	0.017	0.022	0.027	0.031	0.035	0.022	0.026	0.03
3.1-3.3	COPPER alloyed	<650	220	0.019	0.024	0.029	0.011	0.014	0.019	0.024	0.027	0.03	0.019	0.022	0.025
4.1	MAGNESIUM alloyed	<250	500	0.025	0.03	0.035	0.015	0.02	0.025	0.03	0.035	0.04	0.025	0.03	0.035
5.1	PLASTICS Thermoplastic	<100	400	0.022	0.027	0.032	0.013	0.017	0.022	0.027	0.031	0.035	0.022	0.026	0.03
5.2	PLASTICS Duroplastic	<150	350	0.019	0.024	0.029	0.011	0.014	0.019	0.024	0.027	0.03	0.019	0.022	0.025

Dimension	Ø 2x4			Ø 2x40		
Infeed in mm	ae= 1xD	ae= 0.25xD	ae= 0.1xD	ae= 1xD	ae= 0.015xD	ae= 0.01xD
Application	ap= 0.2xD	ap= L2 max	ae= 0.1xD	ap= 0.01xD	ap= L2 max	ae= 0.010xD
Application						

Material	Strength (N/mm ²)	Feed (mm/Z)	Vc (m/min)	fz	fz	fz	fz	fz	fz
N	NON-FERROUS								
1.1	ALUMINIUM alloyed	<500	500	0.03	0.035	0.04	0.02	0.025	0.03
1.2	ALUMINIUM alloyed	<600	480	0.03	0.035	0.04	0.02	0.025	0.03
2.1-2.3	ALUMINIUM casted	<600	450	0.027	0.031	0.035	0.017	0.021	0.025
3.1-3.3	COPPER alloyed	<650	220	0.024	0.027	0.03	0.014	0.017	0.02
4.1	MAGNESIUM alloyed	<250	500	0.03	0.035	0.04	0.02	0.025	0.03
5.1	PLASTICS Thermoplastic	<100	400	0.027	0.031	0.035	0.017	0.021	0.025
5.2	PLASTICS Duroplastic	<150	350	0.024	0.027	0.03	0.014	0.017	0.02

NOTE | Values in the table are the shortest and the longest overhang length (L3) of each dimension; please calculate fz, ap and ae depending on the given values.
 ae/ap(max) = 0.5x corner radius!

Cooling	
Tolerance	d04
Coating	AlphaSlide Rainbow

Strategy	HSC	
Application		
Features	HA	

- Optimized face geometry for excellent surfaces and highest dimensional accuracy
- Defined microbevel for support and stabilization
- Polished chip space for ideal chip evacuation





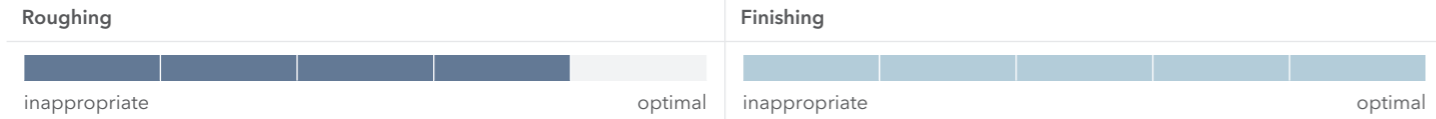
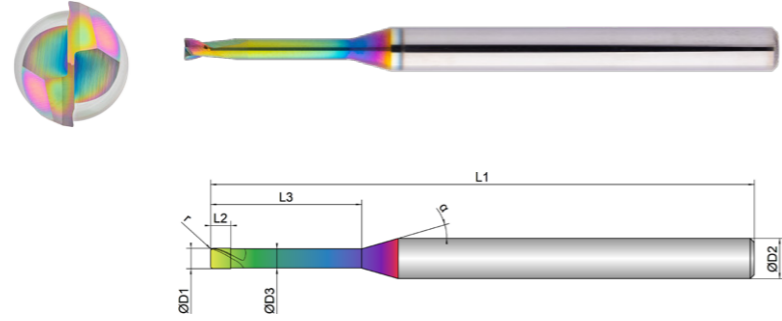





- Multipass milling of 3D contours

- Tolerance D1: -0.001/-0.006 mm
- Tolerance D3: 0/-0.02 mm
- Radius tolerance r: 0/-0.003 mm (measured from 0-90°)



EXN1-M16-0103	D1 mm Ø	D3 mm Ø	L2 mm	L3 mm	L1 mm	D2 mm Ø	z #	r mm		α °
0,8X2	0.8	0.78	0.8	2.0	50.0	4.0	2	0.20	30	16
0,8X4	0.8	0.78	0.8	4.0	50.0	4.0	2	0.20	30	16
0,8X6	0.8	0.78	0.8	6.0	50.0	4.0	2	0.20	30	16
0,8X8	0.8	0.78	0.8	8.0	50.0	4.0	2	0.20	30	16
0,8X10	0.8	0.78	0.8	10.0	50.0	4.0	2	0.20	30	16
0,8X12	0.8	0.78	0.8	12.0	50.0	4.0	2	0.20	30	16
1X2	1.0	0.95	1.0	2.0	50.0	4.0	2	0.20	30	16
1X3	1.0	0.95	1.0	3.0	50.0	4.0	2	0.20	30	16
1X4	1.0	0.95	1.0	4.0	50.0	4.0	2	0.20	30	16
1X5	1.0	0.95	1.0	5.0	50.0	4.0	2	0.20	30	16
1X6	1.0	0.95	1.0	6.0	50.0	4.0	2	0.20	30	16
1X8	1.0	0.95	1.0	8.0	50.0	4.0	2	0.20	30	16
1X10	1.0	0.95	1.0	10.0	50.0	4.0	2	0.20	30	16

EXN1-M16-0103	D1 mm Ø	D3 mm Ø	L2 mm	L3 mm	L1 mm	D2 mm Ø	z #	r mm		α °
1X12	1.0	0.95	1.0	12.0	54.0	4.0	2	0.20	30	16
1X15	1.0	0.95	1.0	15.0	60.0	4.0	2	0.20	30	16
1X20	1.0	0.95	1.0	20.0	60.0	4.0	2	0.20	30	16
1X25	1.0	0.95	1.0	25.0	70.0	4.0	2	0.20	30	16
1X30	1.0	0.95	1.0	30.0	70.0	4.0	2	0.20	30	16
1,2X5	1.2	1.14	1.2	5.0	50.0	4.0	2	0.20	30	16
1,2X10	1.2	1.14	1.2	10.0	50.0	4.0	2	0.20	30	16
1,2X15	1.2	1.14	1.2	15.0	54.0	4.0	2	0.20	30	16
1,2X20	1.2	1.14	1.2	20.0	60.0	4.0	2	0.20	30	16
1,5X4	1.5	1.44	1.5	4.0	50.0	4.0	2	0.20	30	16
1,5X6	1.5	1.44	1.5	6.0	50.0	4.0	2	0.20	30	16
1,5X8	1.5	1.44	1.5	8.0	50.0	4.0	2	0.20	30	16
1,5X10	1.5	1.44	1.5	10.0	50.0	4.0	2	0.20	30	16
1,5X12	1.5	1.44	1.5	12.0	54.0	4.0	2	0.20	30	16
1,5X15	1.5	1.44	1.5	15.0	54.0	4.0	2	0.20	30	16
1,5X20	1.5	1.44	1.5	20.0	60.0	4.0	2	0.20	30	16
1,5X25	1.5	1.44	1.5	25.0	60.0	4.0	2	0.20	30	16
1,5X30	1.5	1.44	1.5	30.0	70.0	4.0	2	0.20	30	16
1,8X8	1.8	1.74	1.8	8.0	50.0	4.0	2	0.20	30	16
1,8X10	1.8	1.74	1.8	10.0	50.0	4.0	2	0.20	30	16
1,8X15	1.8	1.74	1.8	15.0	50.0	4.0	2	0.20	30	16
1,8X20	1.8	1.74	1.8	20.0	54.0	4.0	2	0.20	30	16
2X4	2.0	1.91	2.0	4.0	50.0	4.0	2	0.20	30	16
2X6	2.0	1.91	2.0	6.0	50.0	4.0	2	0.20	30	16
2X8	2.0	1.91	2.0	8.0	50.0	4.0	2	0.20	30	16

EXN1-M16-0103	D1  mm ∅	D3  mm ∅	L2  mm	L3  mm	L1  mm	D2  mm ∅	z  #	r  mm	 °	 °
2X10	2.0	1.91	2.0	10.0	50.0	4.0	2	0.20	30	16
2X12	2.0	1.91	2.0	12.0	54.0	4.0	2	0.20	30	16
2X15	2.0	1.91	2.0	15.0	54.0	4.0	2	0.20	30	16
2X20	2.0	1.91	2.0	20.0	60.0	4.0	2	0.20	30	16
2X25	2.0	1.91	2.0	25.0	70.0	4.0	2	0.20	30	16
2X30	2.0	1.91	2.0	30.0	70.0	4.0	2	0.20	30	16
2X35	2.0	1.91	2.0	35.0	80.0	4.0	2	0.20	30	16
2X40	2.0	1.91	2.0	40.0	80.0	4.0	2	0.20	30	16
2,5X15	2.5	2.41	2.5	15.0	54.0	4.0	2	0.20	30	16
2,5X20	2.5	2.41	2.5	20.0	54.0	4.0	2	0.20	30	16
2,5X25	2.5	2.41	2.5	25.0	60.0	4.0	2	0.20	30	16
2,5X30	2.5	2.41	2.5	30.0	70.0	4.0	2	0.20	30	16
3X6	3.0	2.91	4.5	6.0	50.0	4.0	2	0.20	30	16
3X8	3.0	2.91	4.5	8.0	50.0	4.0	2	0.20	30	16
3X10	3.0	2.91	4.5	10.0	50.0	4.0	2	0.20	30	16
3X12	3.0	2.91	4.5	12.0	50.0	4.0	2	0.20	30	16
3X15	3.0	2.91	4.5	15.0	54.0	4.0	2	0.20	30	16
3X20	3.0	2.91	4.5	20.0	54.0	4.0	2	0.20	30	16
3X25	3.0	2.91	4.5	25.0	60.0	4.0	2	0.20	30	16
3X30	3.0	2.91	4.5	30.0	70.0	4.0	2	0.20	30	16
3X35	3.0	2.91	4.5	35.0	80.0	4.0	2	0.20	30	16
3X40	3.0	2.91	4.5	40.0	80.0	4.0	2	0.20	30	16
3X45	3.0	2.91	4.5	45.0	90.0	4.0	2	0.20	30	16



Download Catalog Pages (PDF)

Material	Strength (N/mm ²)	Feed (mm/Z)	Ø 0.8x2			Ø 0.8x12			Ø 1x2			Ø 1x30		
			fz	fz	fz	fz	fz	fz	fz	fz	fz	fz	fz	fz
N NON-FERROUS		Vc (m/min)												
1.1 ALUMINIUM alloyed	<500	500	0.016	0.02	0.022	0.012	0.015	0.017	0.025	0.03	0.035	0.01	0.015	0.02
1.2 ALUMINIUM alloyed	<600	480	0.016	0.02	0.022	0.012	0.015	0.017	0.025	0.03	0.035	0.01	0.015	0.02
2.1-2.3 ALUMINIUM casted	<600	450	0.015	0.018	0.021	0.011	0.014	0.016	0.022	0.027	0.032	0.008	0.013	0.017
3.1-3.3 COPPER alloyed	<650	220	0.014	0.016	0.02	0.01	0.013	0.015	0.019	0.024	0.029	0.006	0.011	0.014
4.1 MAGNESIUM alloyed	<250	500	0.016	0.02	0.022	0.012	0.015	0.017	0.025	0.03	0.035	0.01	0.015	0.02
5.1 PLASTICS Thermoplastic	<100	400	0.015	0.018	0.021	0.011	0.014	0.016	0.022	0.027	0.032	0.008	0.013	0.017
5.2 PLASTICS Duroplastic	<150	350	0.014	0.016	0.02	0.01	0.013	0.015	0.019	0.024	0.029	0.006	0.011	0.014

Material	Strength (N/mm ²)	Feed (mm/Z)	Ø 1.2x5			Ø 1.2x20			Ø 1.5x4			Ø 1.5x30		
			fz	fz	fz	fz	fz	fz	fz	fz	fz	fz	fz	fz
N NON-FERROUS		Vc (m/min)												
1.1 ALUMINIUM alloyed	<500	500	0.025	0.03	0.035	0.02	0.025	0.03	0.025	0.03	0.035	0.015	0.02	0.025
1.2 ALUMINIUM alloyed	<600	480	0.025	0.03	0.035	0.02	0.025	0.03	0.025	0.03	0.035	0.015	0.02	0.025
2.1-2.3 ALUMINIUM casted	<600	450	0.022	0.027	0.032	0.017	0.022	0.027	0.022	0.027	0.032	0.013	0.017	0.022
3.1-3.3 COPPER alloyed	<650	220	0.019	0.024	0.029	0.014	0.019	0.024	0.019	0.024	0.029	0.011	0.014	0.019
4.1 MAGNESIUM alloyed	<250	500	0.025	0.03	0.035	0.02	0.025	0.03	0.025	0.03	0.035	0.015	0.02	0.025
5.1 PLASTICS Thermoplastic	<100	400	0.022	0.027	0.032	0.017	0.022	0.027	0.022	0.027	0.032	0.013	0.017	0.022
5.2 PLASTICS Duroplastic	<150	350	0.019	0.024	0.029	0.014	0.019	0.024	0.019	0.024	0.029	0.011	0.014	0.019

Material	Strength (N/mm ²)	Feed (mm/Z)	Ø 1.8x8			Ø 1.8x20			Ø 2x4			Ø 2x40		
			fz	fz	fz	fz	fz	fz	fz	fz	fz	fz	fz	fz
N NON-FERROUS		Vc (m/min)												
1.1 ALUMINIUM alloyed	<500	500	0.03	0.035	0.04	0.025	0.03	0.035	0.03	0.035	0.04	0.02	0.025	0.03
1.2 ALUMINIUM alloyed	<600	480	0.03	0.035	0.04	0.025	0.03	0.035	0.03	0.035	0.04	0.02	0.025	0.03
2.1-2.3 ALUMINIUM casted	<600	450	0.027	0.031	0.035	0.022	0.026	0.03	0.027	0.031	0.035	0.017	0.021	0.025
3.1-3.3 COPPER alloyed	<650	220	0.024	0.027	0.03	0.019	0.022	0.025	0.024	0.027	0.03	0.014	0.017	0.02
4.1 MAGNESIUM alloyed	<250	500	0.03	0.035	0.04	0.025	0.03	0.035	0.03	0.035	0.04	0.02	0.025	0.03
5.1 PLASTICS Thermoplastic	<100	400	0.027	0.031	0.035	0.022	0.026	0.03	0.027	0.031	0.035	0.017	0.021	0.025
5.2 PLASTICS Duroplastic	<150	350	0.024	0.027	0.03	0.019	0.022	0.025	0.024	0.027	0.03	0.014	0.017	0.02

NOTE | Values in the table are the shortest and the longest overhang length (L3) of each dimension; please calculate fz, ap and ae depending on the given values.
 ae/ap(max) = 0.5x corner radius!

Dimension	Ø2.5x15			Ø2.5x30			Ø3x6			Ø3x45		
Infeed in mm	ae=1xD	ae=0.25xD	ae=0.1xD	ae=1xD	ae=0.09xD	ae=0.04xD	ae=1xD	ae=0.25xD	ae=0.1xD	ae=1xD	ae=0.05xD	ae=0.02xD
Application	ap=0.2xD	ap=L2 max	ae=0.1xD	ap=0.07xD	ap=L2 max	ae=0.04xD	ap=0.2xD	ap=L2 max	ae=0.1xD	ap=0.04xD	ap=L2 max	ae=0.02xD

N	Material	Strength (N/mm ²)	Feed (mm/Z)	NON-FERROUS											
				Vc (m/min)											
1.1	ALUMINIUM alloyed	<500	500	fz	fz	fz	fz	fz	fz	fz	fz	fz	fz	fz	fz
1.2	ALUMINIUM alloyed	<600	480	0.03	0.035	0.04	0.025	0.03	0.035	0.033	0.038	0.043	0.025	0.03	0.035
2.1-2.3	ALUMINIUM casted	<600	450	0.027	0.031	0.035	0.022	0.026	0.03	0.03	0.034	0.038	0.022	0.026	0.03
3.1-3.3	COPPER alloyed	<650	220	0.024	0.027	0.03	0.019	0.022	0.025	0.027	0.03	0.033	0.019	0.022	0.025
4.1	MAGNESIUM alloyed	<250	500	0.03	0.035	0.04	0.025	0.03	0.035	0.033	0.038	0.043	0.025	0.03	0.035
5.1	PLASTICS Thermoplastic	<100	400	0.027	0.031	0.035	0.022	0.026	0.03	0.03	0.034	0.038	0.022	0.026	0.03
5.2	PLASTICS Duroplastic	<150	350	0.024	0.027	0.03	0.019	0.022	0.025	0.027	0.03	0.033	0.019	0.022	0.025

NOTE | Values in the table are the shortest and the longest overhang length (L3) of each dimension; please calculate fz, ap and ae depending on the given values.
 ae/ap(max)=0.5x corner radius!

Cooling 

Tolerance d04

Coating AlphaSlide Rainbow

Strategy **HSC**

Application 

Features **HA** 



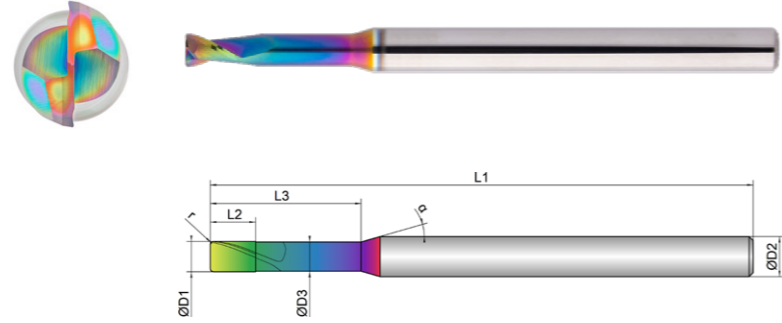

- Optimized face geometry for excellent surfaces and highest dimensional accuracy
- Defined microbevel for support and stabilization
- Polished chip space for ideal chip evacuation

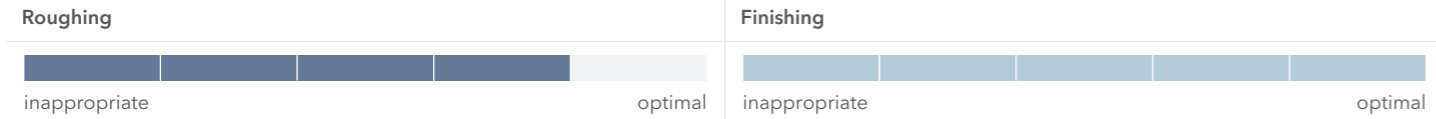

- Multipass milling of 3D contours

- Tolerance D1: -0.001/-0.006 mm
- Tolerance D3: 0/-0.02 mm
- Radius tolerance r: 0/-0.003 mm (measured from 0-90°)



EXN1-M16-0143	D1 mm Ø	D3 mm Ø	L2 mm	L3 mm	L1 mm	D2 mm Ø	z #	r mm		α °
1X2	1.0	0.95	1.0	2.0	50.0	4.0	2	0.30	30	16
1X3	1.0	0.95	1.0	3.0	50.0	4.0	2	0.30	30	16
1X4	1.0	0.95	1.0	4.0	50.0	4.0	2	0.30	30	16
1X5	1.0	0.95	1.0	5.0	50.0	4.0	2	0.30	30	16
1X6	1.0	0.95	1.0	6.0	50.0	4.0	2	0.30	30	16
1X8	1.0	0.95	1.0	8.0	50.0	4.0	2	0.30	30	16
1X10	1.0	0.95	1.0	10.0	50.0	4.0	2	0.30	30	16
1X12	1.0	0.95	1.0	12.0	54.0	4.0	2	0.30	30	16
1X15	1.0	0.95	1.0	15.0	60.0	4.0	2	0.30	30	16
1X20	1.0	0.95	1.0	20.0	60.0	4.0	2	0.30	30	16
1X25	1.0	0.95	1.0	25.0	70.0	4.0	2	0.30	30	16
1X30	1.0	0.95	1.0	30.0	70.0	4.0	2	0.30	30	16
1,2X5	1.2	1.14	1.2	5.0	50.0	4.0	2	0.30	30	16
1,2X10	1.2	1.14	1.2	10.0	50.0	4.0	2	0.30	30	16
1,2X15	1.2	1.14	1.2	15.0	54.0	4.0	2	0.30	30	16
1,2X20	1.2	1.14	1.2	20.0	60.0	4.0	2	0.30	30	16
1,5X4	1.5	1.44	1.5	4.0	50.0	4.0	2	0.30	30	16
1,5X6	1.5	1.44	1.5	6.0	50.0	4.0	2	0.30	30	16
1,5X8	1.5	1.44	1.5	8.0	50.0	4.0	2	0.30	30	16

EXN1-M16-0143	D1 mm Ø	D3 mm Ø	L2 mm	L3 mm	L1 mm	D2 mm Ø	z #	r mm		α °
1,5X10	1.5	1.44	1.5	10.0	50.0	4.0	2	0.30	30	16
1,5X12	1.5	1.44	1.5	12.0	54.0	4.0	2	0.30	30	16
1,5X15	1.5	1.44	1.5	15.0	54.0	4.0	2	0.30	30	16
1,5X20	1.5	1.44	1.5	20.0	60.0	4.0	2	0.30	30	16
1,5X25	1.5	1.44	1.5	25.0	60.0	4.0	2	0.30	30	16
1,5X30	1.5	1.44	1.5	30.0	70.0	4.0	2	0.30	30	16
1,8X8	1.8	1.74	1.8	8.0	50.0	4.0	2	0.30	30	16
1,8X10	1.8	1.74	1.8	10.0	50.0	4.0	2	0.30	30	16
1,8X15	1.8	1.74	1.8	15.0	50.0	4.0	2	0.30	30	16
1,8X20	1.8	1.74	1.8	20.0	54.0	4.0	2	0.30	30	16
2X4	2.0	1.91	2.0	4.0	50.0	4.0	2	0.30	30	16
2X6	2.0	1.91	2.0	6.0	50.0	4.0	2	0.30	30	16
2X8	2.0	1.91	2.0	8.0	50.0	4.0	2	0.30	30	16
2X10	2.0	1.91	2.0	10.0	50.0	4.0	2	0.30	30	16
2X12	2.0	1.91	2.0	12.0	54.0	4.0	2	0.30	30	16
2X15	2.0	1.91	2.0	15.0	54.0	4.0	2	0.30	30	16
2X20	2.0	1.91	2.0	20.0	60.0	4.0	2	0.30	30	16
2X25	2.0	1.91	2.0	25.0	70.0	4.0	2	0.30	30	16
2X30	2.0	1.91	2.0	30.0	70.0	4.0	2	0.30	30	16
2X35	2.0	1.91	2.0	35.0	80.0	4.0	2	0.30	30	16
2X40	2.0	1.91	2.0	40.0	80.0	4.0	2	0.30	30	16
2,5X15	2.5	2.41	2.5	15.0	54.0	4.0	2	0.30	30	16
2,5X20	2.5	2.41	2.5	20.0	54.0	4.0	2	0.30	30	16
2,5X25	2.5	2.41	2.5	25.0	60.0	4.0	2	0.30	30	16
2,5X30	2.5	2.41	2.5	30.0	70.0	4.0	2	0.30	30	16
3X6	3.0	2.91	4.5	6.0	50.0	4.0	2	0.30	30	16
3X8	3.0	2.91	4.5	8.0	50.0	4.0	2	0.30	30	16
3X10	3.0	2.91	4.5	10.0	50.0	4.0	2	0.30	30	16
3X12	3.0	2.91	4.5	12.0	50.0	4.0	2	0.30	30	16
3X15	3.0	2.91	4.5	15.0	54.0	4.0	2	0.30	30	16
3X20	3.0	2.91	4.5	20.0	54.0	4.0	2	0.30	30	16
3X25	3.0	2.91	4.5	25.0	60.0	4.0	2	0.30	30	16
3X30	3.0	2.91	4.5	30.0	70.0	4.0	2	0.30	30	16
3X35	3.0	2.91	4.5	35.0	80.0	4.0	2	0.30	30	16
3X40	3.0	2.91	4.5	40.0	80.0	4.0	2	0.30	30	16
3X45	3.0	2.91	4.5	45.0	90.0	4.0	2	0.30	30	16



Download Catalog Pages (PDF)

Dimension	Ø 1x2			Ø 1x30			Ø 1.2x5			Ø 1.2x20		
Infeed in mm	ae= 1xD	ae= 0.25xD	ae= 0.1xD	ae= 1xD	ae= 0.015xD	ae= 0.01xD	ae= 1xD	ae= 0.25xD	ae= 0.1xD	ae= 1xD	ae= 0.04xD	ae= 0.015xD
Application	ap= 0.2xD	ap= L2 max	ap= 0.1xD	ap= 0.01xD	ap= L2 max	ap= 0.01xD	ap= 0.2xD	ap= L2 max	ap= 0.1xD	ap= 0.03xD	ap= L2 max	ap= 0.015xD

Material	Strength (N/mm ²)	Feed (mm/Z)	Vc (m/min)	fz	fz	fz	fz	fz	fz	fz	fz	fz	fz	fz	
N NON-FERROUS															
1.1 ALUMINIUM alloyed	<500	500		0.025	0.03	0.035	0.01	0.015	0.02	0.025	0.03	0.035	0.02	0.025	0.03
1.2 ALUMINIUM alloyed	<600	480		0.025	0.03	0.035	0.01	0.015	0.02	0.025	0.03	0.035	0.02	0.025	0.03
2.1-2.3 ALUMINIUM casted	<600	450		0.022	0.027	0.032	0.008	0.013	0.017	0.022	0.027	0.032	0.017	0.022	0.027
3.1-3.3 COPPER alloyed	<650	220		0.019	0.024	0.029	0.006	0.011	0.014	0.019	0.024	0.029	0.014	0.019	0.024
4.1 MAGNESIUM alloyed	<250	500		0.025	0.03	0.035	0.01	0.015	0.02	0.025	0.03	0.035	0.02	0.025	0.03
5.1 PLASTICS Thermoplastic	<100	400		0.022	0.027	0.032	0.008	0.013	0.017	0.022	0.027	0.032	0.017	0.022	0.027
5.2 PLASTICS Duroplastic	<150	350		0.019	0.024	0.029	0.006	0.011	0.014	0.019	0.024	0.029	0.014	0.019	0.024

Dimension	Ø 1.5x4			Ø 1.5x30			Ø 1.8x8			Ø 1.8x20		
Infeed in mm	ae= 1xD	ae= 0.25xD	ae= 0.1xD	ae= 1xD	ae= 0.03xD	ae= 0.01xD	ae= 1xD	ae= 0.25xD	ae= 0.1xD	ae= 1xD	ae= 0.13xD	ae= 0.05xD
Application	ap= 0.2xD	ap= L2 max	ap= 0.1xD	ap= 0.02xD	ap= L2 max	ap= 0.01xD	ap= 0.2xD	ap= L2 max	ap= 0.1xD	ap= 0.1xD	ap= L2 max	ap= 0.05xD

Material	Strength (N/mm ²)	Feed (mm/Z)	Vc (m/min)	fz	fz	fz	fz	fz	fz	fz	fz	fz	fz	fz	
N NON-FERROUS															
1.1 ALUMINIUM alloyed	<500	500		0.025	0.03	0.035	0.015	0.02	0.025	0.03	0.035	0.04	0.025	0.03	0.035
1.2 ALUMINIUM alloyed	<600	480		0.025	0.03	0.035	0.015	0.02	0.025	0.03	0.035	0.04	0.025	0.03	0.035
2.1-2.3 ALUMINIUM casted	<600	450		0.022	0.027	0.032	0.013	0.017	0.022	0.027	0.031	0.035	0.022	0.026	0.03
3.1-3.3 COPPER alloyed	<650	220		0.019	0.024	0.029	0.011	0.014	0.019	0.024	0.027	0.03	0.019	0.022	0.025
4.1 MAGNESIUM alloyed	<250	500		0.025	0.03	0.035	0.015	0.02	0.025	0.03	0.035	0.04	0.025	0.03	0.035
5.1 PLASTICS Thermoplastic	<100	400		0.022	0.027	0.032	0.013	0.017	0.022	0.027	0.031	0.035	0.022	0.026	0.03
5.2 PLASTICS Duroplastic	<150	350		0.019	0.024	0.029	0.011	0.014	0.019	0.024	0.027	0.03	0.019	0.022	0.025

Dimension	Ø 2x4			Ø 2x40			Ø 2.5x15			Ø 2.5x30		
Infeed in mm	ae= 1xD	ae= 0.25xD	ae= 0.1xD	ae= 1xD	ae= 0.015xD	ae= 0.01xD	ae= 1xD	ae= 0.25xD	ae= 0.1xD	ae= 1xD	ae= 0.09xD	ae= 0.04xD
Application	ap= 0.2xD	ap= L2 max	ap= 0.1xD	ap= 0.01xD	ap= L2 max	ap= 0.01xD	ap= 0.2xD	ap= L2 max	ap= 0.1xD	ap= 0.07xD	ap= L2 max	ap= 0.04xD

Material	Strength (N/mm ²)	Feed (mm/Z)	Vc (m/min)	fz	fz	fz	fz	fz	fz	fz	fz	fz	fz	fz	
N NON-FERROUS															
1.1 ALUMINIUM alloyed	<500	500		0.03	0.035	0.04	0.02	0.025	0.03	0.03	0.035	0.04	0.025	0.03	0.035
1.2 ALUMINIUM alloyed	<600	480		0.03	0.035	0.04	0.02	0.025	0.03	0.03	0.035	0.04	0.025	0.03	0.035
2.1-2.3 ALUMINIUM casted	<600	450		0.027	0.031	0.035	0.017	0.021	0.025	0.027	0.031	0.035	0.022	0.026	0.03
3.1-3.3 COPPER alloyed	<650	220		0.024	0.027	0.03	0.014	0.017	0.02	0.024	0.027	0.03	0.019	0.022	0.025
4.1 MAGNESIUM alloyed	<250	500		0.03	0.035	0.04	0.02	0.025	0.03	0.03	0.035	0.04	0.025	0.03	0.035
5.1 PLASTICS Thermoplastic	<100	400		0.027	0.031	0.035	0.017	0.021	0.025	0.027	0.031	0.035	0.022	0.026	0.03
5.2 PLASTICS Duroplastic	<150	350		0.024	0.027	0.03	0.014	0.017	0.02	0.024	0.027	0.03	0.019	0.022	0.025

NOTE | Values in the table are the shortest and the longest overhang length (L3) of each dimension; please calculate fz, ap and ae depending on the given values.
 ae/ap(max) = 0.5x corner radius!

Dimension	Ø 3x6			Ø 3x45		
Infeed in mm	ae= 1xD	ae= 0.25xD	ae= 0.1xD	ae= 1xD	ae= 0.05xD	ae= 0.02xD
Application	ap= 0.2xD	ap= L2 max	ap= 0.1xD	ap= 0.04xD	ap= L2 max	ap= 0.02xD

Material	Strength (N/mm ²)	Feed (mm/Z)	Vc (m/min)	fz	fz	fz	fz	fz	fz
N NON-FERROUS									
1.1 ALUMINIUM alloyed	<500	500		0.033	0.038	0.043	0.025	0.03	0.035
1.2 ALUMINIUM alloyed	<600	480		0.033	0.038	0.043	0.025	0.03	0.035
2.1-2.3 ALUMINIUM casted	<600	450		0.03	0.034	0.038	0.022	0.026	0.03
3.1-3.3 COPPER alloyed	<650	220		0.027	0.03	0.033	0.019	0.022	0.025
4.1 MAGNESIUM alloyed	<250	500		0.033	0.038	0.043	0.025	0.03	0.035
5.1 PLASTICS Thermoplastic	<100	400		0.03	0.034	0.038	0.022	0.026	0.03
5.2 PLASTICS Duroplastic	<150	350		0.027	0.03	0.033	0.019	0.022	0.025

NOTE | Values in the table are the shortest and the longest overhang length (L3) of each dimension; please calculate fz, ap and ae depending on the given values.
 ae/ap(max) = 0.5x corner radius!



Download Catalog Pages (PDF)

Dimension	Ø 1.5x4			Ø 1.5x30			Ø 1.8x8			Ø 1.8x20		
Infeed in mm	ae= 1xD	ae= 0.25xD	ae= 0.1xD	ae= 1xD	ae= 0.03xD	ae= 0.01xD	ae= 1xD	ae= 0.25xD	ae= 0.1xD	ae= 1xD	ae= 0.13xD	ae= 0.05xD
Application	ap= 0.2xD	ap= L2 max	ap= 0.1xD	ap= 0.02xD	ap= L2 max	ap= 0.01xD	ap= 0.2xD	ap= L2 max	ap= 0.1xD	ap= 0.1xD	ap= L2 max	ap= 0.05xD

Material	Strength (N/mm ²)	Feed (mm/Z)	Vc (m/min)	fz	fz	fz	fz	fz	fz	fz	fz	fz	fz	fz	
N NON-FERROUS															
1.1 ALUMINIUM alloyed	<500	500	500	0.025	0.03	0.035	0.015	0.02	0.025	0.03	0.035	0.04	0.025	0.03	0.035
1.2 ALUMINIUM alloyed	<600	480	480	0.025	0.03	0.035	0.015	0.02	0.025	0.03	0.035	0.04	0.025	0.03	0.035
2.1-2.3 ALUMINIUM casted	<600	450	450	0.022	0.027	0.032	0.013	0.017	0.022	0.027	0.031	0.035	0.022	0.026	0.03
3.1-3.3 COPPER alloyed	<650	220	220	0.019	0.024	0.029	0.011	0.014	0.019	0.024	0.027	0.03	0.019	0.022	0.025
4.1 MAGNESIUM alloyed	<250	500	500	0.025	0.03	0.035	0.015	0.02	0.025	0.03	0.035	0.04	0.025	0.03	0.035
5.1 PLASTICS Thermoplastic	<100	400	400	0.022	0.027	0.032	0.013	0.017	0.022	0.027	0.031	0.035	0.022	0.026	0.03
5.2 PLASTICS Duroplastic	<150	350	350	0.019	0.024	0.029	0.011	0.014	0.019	0.024	0.027	0.03	0.019	0.022	0.025

Dimension	Ø 2x4			Ø 2x40			Ø 2.5x12			Ø 2.5x30		
Infeed in mm	ae= 1xD	ae= 0.25xD	ae= 0.1xD	ae= 1xD	ae= 0.015xD	ae= 0.01xD	ae= 1xD	ae= 0.25xD	ae= 0.1xD	ae= 1xD	ae= 0.09xD	ae= 0.04xD
Application	ap= 0.2xD	ap= L2 max	ap= 0.1xD	ap= 0.01xD	ap= L2 max	ap= 0.01xD	ap= 0.2xD	ap= L2 max	ap= 0.1xD	ap= 0.07xD	ap= L2 max	ap= 0.04xD

Material	Strength (N/mm ²)	Feed (mm/Z)	Vc (m/min)	fz	fz	fz	fz	fz	fz	fz	fz	fz	fz	fz	
N NON-FERROUS															
1.1 ALUMINIUM alloyed	<500	500	500	0.03	0.035	0.04	0.02	0.025	0.03	0.03	0.035	0.04	0.025	0.03	0.035
1.2 ALUMINIUM alloyed	<600	480	480	0.03	0.035	0.04	0.02	0.025	0.03	0.03	0.035	0.04	0.025	0.03	0.035
2.1-2.3 ALUMINIUM casted	<600	450	450	0.027	0.031	0.035	0.017	0.021	0.025	0.027	0.031	0.035	0.022	0.026	0.03
3.1-3.3 COPPER alloyed	<650	220	220	0.024	0.027	0.03	0.014	0.017	0.02	0.024	0.027	0.03	0.019	0.022	0.025
4.1 MAGNESIUM alloyed	<250	500	500	0.03	0.035	0.04	0.02	0.025	0.03	0.03	0.035	0.04	0.025	0.03	0.035
5.1 PLASTICS Thermoplastic	<100	400	400	0.027	0.031	0.035	0.017	0.021	0.025	0.027	0.031	0.035	0.022	0.026	0.03
5.2 PLASTICS Duroplastic	<150	350	350	0.024	0.027	0.03	0.014	0.017	0.02	0.024	0.027	0.03	0.019	0.022	0.025

Dimension	Ø 3x6			Ø 3x45		
Infeed in mm	ae= 1xD	ae= 0.25xD	ae= 0.1xD	ae= 1xD	ae= 0.05xD	ae= 0.02xD
Application	ap= 0.2xD	ap= L2 max	ap= 0.1xD	ap= 0.04xD	ap= L2 max	ap= 0.02xD

Material	Strength (N/mm ²)	Feed (mm/Z)	Vc (m/min)	fz	fz	fz	fz	fz	fz
N NON-FERROUS									
1.1 ALUMINIUM alloyed	<500	500	500	0.033	0.038	0.043	0.025	0.03	0.035
1.2 ALUMINIUM alloyed	<600	480	480	0.033	0.038	0.043	0.025	0.03	0.035
2.1-2.3 ALUMINIUM casted	<600	450	450	0.03	0.034	0.038	0.022	0.026	0.03
3.1-3.3 COPPER alloyed	<650	220	220	0.027	0.03	0.033	0.019	0.022	0.025
4.1 MAGNESIUM alloyed	<250	500	500	0.033	0.038	0.043	0.025	0.03	0.035
5.1 PLASTICS Thermoplastic	<100	400	400	0.03	0.034	0.038	0.022	0.026	0.03
5.2 PLASTICS Duroplastic	<150	350	350	0.027	0.03	0.033	0.019	0.022	0.025

NOTE | Values in the table are the shortest and the longest overhang length (L3) of each dimension; please calculate fz, ap and ae depending on the given values.

ae/ap(max) = 0.5x corner radius!

Cooling	
Tolerance	d04
Coating	AlphaSlide Rainbow

Strategy	HSC	
Application		
Features	HA	

- Optimized face geometry for excellent surfaces and highest dimensional accuracy
- Defined microbevel for support and stabilization
- Polished chip space for ideal chip evacuation

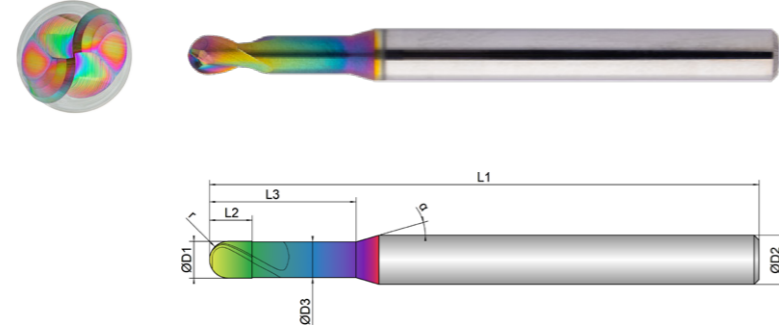

- Tolerance D1: -0.001/-0.006 mm
- Tolerance D3: 0/-0.02 mm
- Radius tolerance r: 0/-0.003 mm (measured from 0-90°)

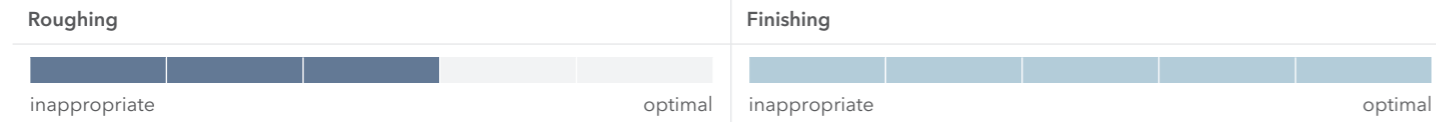

EXN1-M17-0003	D1 mm 	D3 mm 	L2 mm 	L3 mm 	L1 mm 	D2 mm 	z # 	r mm 	α ° 	
0,1X0,3	0.1	0.08	0.1	0.3	45.0	4.0	2	0.05	30	16
0,1X0,5	0.1	0.08	0.1	0.5	45.0	4.0	2	0.05	30	16
0,1X1	0.1	0.08	0.1	1.0	45.0	4.0	2	0.05	30	16
0,2X0,5	0.2	0.17	0.2	0.5	45.0	4.0	2	0.10	30	16
0,2X1	0.2	0.17	0.2	1.0	45.0	4.0	2	0.10	30	16
0,2X2	0.2	0.17	0.2	2.0	45.0	4.0	2	0.10	30	16
0,2X3	0.2	0.17	0.2	3.0	45.0	4.0	2	0.10	30	16
0,3X0,5	0.3	0.27	0.2	0.5	45.0	4.0	2	0.15	30	16
0,3X1	0.3	0.27	0.2	1.0	45.0	4.0	2	0.15	30	16
0,3X2	0.3	0.27	0.2	2.0	45.0	4.0	2	0.15	30	16
0,3X3	0.3	0.27	0.2	3.0	45.0	4.0	2	0.15	30	16
0,3X4	0.3	0.27	0.2	4.0	45.0	4.0	2	0.15	30	16
0,3X6	0.3	0.27	0.2	6.0	45.0	4.0	2	0.15	30	16
0,4X1	0.4	0.37	0.3	1.0	45.0	4.0	2	0.20	30	16
0,4X2	0.4	0.37	0.3	2.0	45.0	4.0	2	0.20	30	16

EXN1-M17-0003	D1 mm 	D3 mm 	L2 mm 	L3 mm 	L1 mm 	D2 mm 	z # 	r mm 	α ° 	
0,4X3	0.4	0.37	0.3	3.0	45.0	4.0	2	0.20	30	16
0,4X4	0.4	0.37	0.3	4.0	45.0	4.0	2	0.20	30	16
0,4X6	0.4	0.37	0.3	6.0	45.0	4.0	2	0.20	30	16
0,4X8	0.4	0.37	0.3	8.0	45.0	4.0	2	0.20	30	16
0,5X1	0.5	0.47	0.4	1.0	45.0	4.0	2	0.25	30	16
0,5X1,5	0.5	0.47	0.4	1.5	45.0	4.0	2	0.25	30	16
0,5X2	0.5	0.47	0.4	2.0	45.0	4.0	2	0.25	30	16
0,5X3	0.5	0.47	0.4	3.0	45.0	4.0	2	0.25	30	16
0,5X4	0.5	0.47	0.4	4.0	45.0	4.0	2	0.25	30	16
0,5X6	0.5	0.47	0.4	6.0	45.0	4.0	2	0.25	30	16
0,5X8	0.5	0.47	0.4	8.0	45.0	4.0	2	0.25	30	16
0,6X2	0.6	0.57	0.5	2.0	45.0	4.0	2	0.30	30	16
0,6X3	0.6	0.57	0.5	3.0	45.0	4.0	2	0.30	30	16
0,6X4	0.6	0.57	0.5	4.0	45.0	4.0	2	0.30	30	16
0,6X6	0.6	0.57	0.5	6.0	45.0	4.0	2	0.30	30	16
0,6X8	0.6	0.57	0.5	8.0	45.0	4.0	2	0.30	30	16
0,8X2	0.8	0.77	0.6	2.0	45.0	4.0	2	0.40	30	16
0,8X3	0.8	0.77	0.6	3.0	45.0	4.0	2	0.40	30	16
0,8X4	0.8	0.77	0.6	4.0	45.0	4.0	2	0.40	30	16
0,8X6	0.8	0.77	0.6	6.0	45.0	4.0	2	0.40	30	16
0,8X8	0.8	0.77	0.6	8.0	45.0	4.0	2	0.40	30	16
1X2	1.0	0.96	0.8	2.0	45.0	4.0	2	0.50	30	16
1X3	1.0	0.96	0.8	3.0	45.0	4.0	2	0.50	30	16
1X4	1.0	0.96	0.8	4.0	45.0	4.0	2	0.50	30	16
1X5	1.0	0.96	0.8	5.0	45.0	4.0	2	0.50	30	16
1X6	1.0	0.96	0.8	6.0	45.0	4.0	2	0.50	30	16
1X8	1.0	0.96	0.8	8.0	45.0	4.0	2	0.50	30	16

EXN1-M17-0003	D1	D3	L2	L3	L1	D2	z	r	α	
	mm ∅	mm ∅	mm	mm	mm	mm ∅	#	mm	°	°
1X10	1.0	0.96	0.8	10.0	50.0	4.0	2	0.50	30	16
1X12	1.0	0.96	0.8	12.0	50.0	4.0	2	0.50	30	16
1,2X3	1.2	1.16	1.0	3.0	45.0	4.0	2	0.60	30	16
1,2X4	1.2	1.16	1.0	4.0	45.0	4.0	2	0.60	30	16
1,2X6	1.2	1.16	1.0	6.0	45.0	4.0	2	0.60	30	16
1,2X8	1.2	1.16	1.0	8.0	45.0	4.0	2	0.60	30	16
1,2X10	1.2	1.16	1.0	10.0	45.0	4.0	2	0.60	30	16
1,2X12	1.2	1.16	1.0	12.0	50.0	4.0	2	0.60	30	16
1,2X20	1.2	1.16	1.0	20.0	54.0	4.0	2	0.60	30	16
1,5X3	1.5	1.44	1.2	3.0	45.0	4.0	2	0.75	30	16
1,5X4	1.5	1.44	1.2	4.0	45.0	4.0	2	0.75	30	16
1,5X6	1.5	1.44	1.2	6.0	45.0	4.0	2	0.75	30	16
1,5X8	1.5	1.44	1.2	8.0	45.0	4.0	2	0.75	30	16
1,5X10	1.5	1.44	1.2	10.0	45.0	4.0	2	0.75	30	16
1,5X12	1.5	1.44	1.2	12.0	50.0	4.0	2	0.75	30	16
1,8X8	1.8	1.74	1.4	8.0	45.0	4.0	2	0.90	30	16
1,8X10	1.8	1.74	1.4	10.0	45.0	4.0	2	0.90	30	16
1,8X12	1.8	1.74	1.4	12.0	50.0	4.0	2	0.90	30	16
2X4	2.0	1.94	1.6	4.0	45.0	4.0	2	1.00	30	16
2X6	2.0	1.94	1.6	6.0	45.0	4.0	2	1.00	30	16
2X8	2.0	1.94	1.6	8.0	45.0	4.0	2	1.00	30	16
2X10	2.0	1.94	1.6	10.0	45.0	4.0	2	1.00	30	16
2X12	2.0	1.94	1.6	12.0	45.0	4.0	2	1.00	30	16
3X6	3.0	2.92	3.5	6.0	45.0	4.0	2	1.50	30	16
3X8	3.0	2.92	3.5	8.0	45.0	4.0	2	1.50	30	16
3X10	3.0	2.92	3.5	10.0	45.0	4.0	2	1.50	30	16
3X12	3.0	2.92	3.5	12.0	45.0	4.0	2	1.50	30	16



Download Catalog Pages (PDF)

Dimension	∅0.1x0.3	∅0.1x1	∅0.2x0.5	∅0.2x3	∅0.3x0.5	∅0.3x6	∅0.4x1	∅0.4x8	∅0.5x1	∅0.5x8
Infeed in mm	ae=0.1xD ap=0.1xD	ae=0.05xD ap=0.05xD	ae=0.1xD ap=0.1xD	ae=0.02xD ap=0.02xD	ae=0.1xD ap=0.1xD	ae=0.01xD ap=0.01xD	ae=0.1xD ap=0.1xD	ae=0.01xD ap=0.01xD	ae=0.1xD ap=0.1xD	ae=0.015xD ap=0.015xD
Application										

N	Material	Strength (N/mm ²)	Feed (mm/Z)	Vc (m/min)									
				NON-FERROUS									
1.1	ALUMINIUM alloyed	<500	500	0.012	0.007	0.014	0.008	0.014	0.008	0.018	0.009	0.016	0.012
1.2	ALUMINIUM alloyed	<600	480	0.012	0.007	0.014	0.008	0.014	0.008	0.018	0.009	0.016	0.012
2.1-2.3	ALUMINIUM casted	<600	450	0.011	0.006	0.013	0.007	0.013	0.007	0.017	0.008	0.015	0.011
3.1-3.3	COPPER alloyed	<650	220	0.01	0.005	0.012	0.006	0.012	0.006	0.016	0.007	0.014	0.01
4.1	MAGNESIUM alloyed	<250	500	0.012	0.007	0.014	0.008	0.014	0.008	0.018	0.009	0.016	0.012
5.1	PLASTICS Thermoplastic	<100	400	0.011	0.006	0.013	0.007	0.013	0.007	0.017	0.008	0.015	0.011
5.2	PLASTICS Duroplastic	<150	350	0.01	0.005	0.012	0.006	0.012	0.006	0.016	0.007	0.014	0.01

Dimension	∅0.6x2	∅0.6x8	∅0.8x2	∅0.8x8	∅1x2	∅1x12	∅1.2x3	∅1.2x20	∅1.5x3	∅1.5x12
Infeed in mm	ae=0.1xD ap=0.1xD	ae=0.025xD ap=0.025xD	ae=0.1xD ap=0.1xD	ae=0.05xD ap=0.05xD	ae=0.1xD ap=0.1xD	ae=0.03xD ap=0.03xD	ae=0.1xD ap=0.1xD	ae=0.015xD ap=0.015xD	ae=0.1xD ap=0.1xD	ae=0.07xD ap=0.07xD
Application										





N	Material	Strength (N/mm ²)	Feed (mm/Z)	Vc (m/min)									
				NON-FERROUS									
1.1	ALUMINIUM alloyed	<500	500	0.022	0.017	0.022	0.017	0.035	0.028	0.035	0.025	0.035	0.03
1.2	ALUMINIUM alloyed	<600	480	0.022	0.017	0.022	0.017	0.035	0.028	0.035	0.025	0.035	0.03
2.1-2.3	ALUMINIUM casted	<600	450	0.021	0.016	0.021	0.016	0.032	0.026	0.032	0.023	0.032	0.027
3.1-3.3	COPPER alloyed	<650	220	0.02	0.015	0.02	0.015	0.029	0.024	0.029	0.021	0.029	0.024
4.1	MAGNESIUM alloyed	<250	500	0.022	0.017	0.022	0.017	0.035	0.028	0.035	0.025	0.035	0.03
5.1	PLASTICS Thermoplastic	<100	400	0.021	0.016	0.021	0.016	0.032	0.026	0.032	0.023	0.032	0.027
5.2	PLASTICS Duroplastic	<150	350	0.02	0.015	0.02	0.015	0.029	0.024	0.029	0.021	0.029	0.024



Dimension	∅1.8x8	∅1.8x12	∅2x4	∅2x12	∅3x6	∅3x12
Infeed in mm	ae=0.1xD ap=0.1xD	ae=0.09xD ap=0.09xD	ae=0.1xD ap=0.1xD	ae=0.09xD ap=0.09xD	ae=0.1xD ap=0.1xD	ae=0.1xD ap=0.1xD
Application						

N	Material	Strength (N/mm ²)	Feed (mm/Z)	Vc (m/min)					
				NON-FERROUS					
1.1	ALUMINIUM alloyed	<500	500	0.04	0.035	0.04	0.035	0.043	0.04
1.2	ALUMINIUM alloyed	<600	480	0.04	0.035	0.04	0.035	0.043	0.04
2.1-2.3	ALUMINIUM casted	<600	450	0.035	0.032	0.035	0.032	0.038	0.035
3.1-3.3	COPPER alloyed	<650	220	0.03	0.029	0.03	0.029	0.033	0.03
4.1	MAGNESIUM alloyed	<250	500	0.04	0.035	0.04	0.035	0.043	0.04
5.1	PLASTICS Thermoplastic	<100	400	0.035	0.032	0.035	0.032	0.038	0.035
5.2	PLASTICS Duroplastic	<150	350	0.03	0.029	0.03	0.029	0.033	0.03

NOTE | Values in the table are the shortest and the longest overhang length (L3) of each dimension; please calculate fz, ap and ae depending on the given values.

Cooling 
Tolerance d04
Coating AlphaSlide Rainbow

Strategy HSC 
Application 
Features HA  

- Optimized face geometry for excellent surfaces and highest dimensional accuracy
- Defined microbevel for support and stabilization
- Polished chip space for ideal chip evacuation

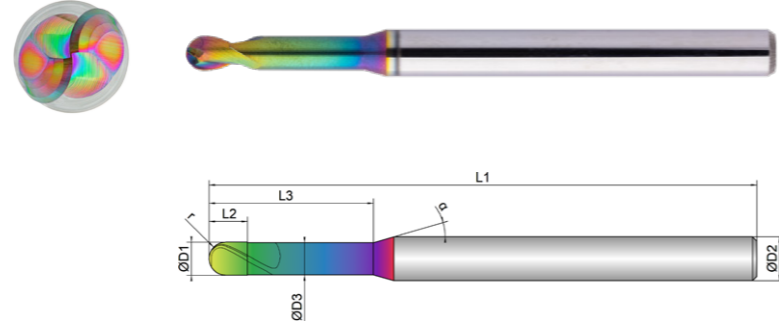

- Tolerance D1: -0.001/-0.006 mm
- Tolerance D3: 0/-0.02 mm
- Radius tolerance r: 0/-0.003 mm (measured from 0-90°)

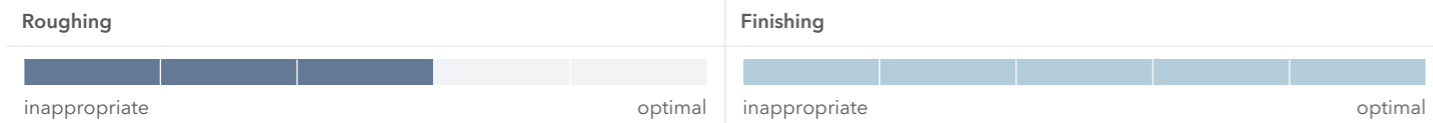

EXN1-M17-0013	D1 mm ∅	D3 mm ∅	L2 mm	L3 mm	L1 mm	D2 mm ∅	z #	r mm	α °
0,5X10	0.5	0.47	0.4	10.0	50.0	4.0	2	0.25	30
0,6X10	0.6	0.57	0.5	10.0	50.0	4.0	2	0.30	30
0,8X10	0.8	0.77	0.6	10.0	50.0	4.0	2	0.40	30
0,8X12	0.8	0.77	0.6	12.0	50.0	4.0	2	0.40	30
1X15	1.0	0.96	0.8	15.0	50.0	4.0	2	0.50	30
1X20	1.0	0.96	0.8	20.0	60.0	4.0	2	0.50	30
1X25	1.0	0.96	0.8	25.0	60.0	4.0	2	0.50	30
1X30	1.0	0.96	0.8	30.0	70.0	4.0	2	0.50	30
1,2X15	1.2	1.16	1.0	15.0	54.0	4.0	2	0.60	30
1,5X15	1.5	1.44	1.2	15.0	50.0	4.0	2	0.75	30
1,5X20	1.5	1.44	1.2	20.0	60.0	4.0	2	0.75	30
1,5X25	1.5	1.44	1.2	25.0	60.0	4.0	2	0.75	30
1,5X30	1.5	1.44	1.2	30.0	70.0	4.0	2	0.75	30
1,8X15	1.8	1.74	1.4	15.0	50.0	4.0	2	0.90	30

EXN1-M17-0013	D1 mm ∅	D3 mm ∅	L2 mm	L3 mm	L1 mm	D2 mm ∅	z #	r mm	α °
1,8X20	1.8	1.74	1.4	20.0	54.0	4.0	2	0.90	30
2X12	2.0	1.94	1.6	12.0	50.0	4.0	2	1.00	30
2X15	2.0	1.94	1.6	15.0	50.0	4.0	2	1.00	30
2X20	2.0	1.94	1.6	20.0	60.0	4.0	2	1.00	30
2X25	2.0	1.94	1.6	25.0	60.0	4.0	2	1.00	30
2X30	2.0	1.94	1.6	30.0	70.0	4.0	2	1.00	30
2X35	2.0	1.94	1.6	35.0	80.0	4.0	2	1.00	30
2X40	2.0	1.94	1.6	40.0	80.0	4.0	2	1.00	30
2,5X15	2.5	2.41	2.0	15.0	50.0	4.0	2	1.25	30
2,5X20	2.5	2.41	2.0	20.0	54.0	4.0	2	1.25	30
2,5X25	2.5	2.41	2.0	25.0	60.0	4.0	2	1.25	30
2,5X30	2.5	2.41	2.0	30.0	70.0	4.0	2	1.25	30
3X15	3.0	2.92	3.5	15.0	50.0	4.0	2	1.50	30
3X20	3.0	2.92	3.5	20.0	54.0	4.0	2	1.50	30
3X25	3.0	2.92	3.5	25.0	60.0	4.0	2	1.50	30
3X30	3.0	2.92	3.5	30.0	70.0	4.0	2	1.50	30
3X35	3.0	2.92	3.5	35.0	70.0	4.0	2	1.50	30
3X40	3.0	2.92	3.5	40.0	80.0	4.0	2	1.50	30
3X45	3.0	2.92	3.5	45.0	80.0	4.0	2	1.50	30



Download Catalog Pages (PDF)

Dimension	Ø0.5x10	Ø0.610	Ø0.8x10	Ø0.8x12	Ø1x15	Ø1x30	Ø1.2x15	Ø1.5x15	Ø1.5x30	Ø1.8x15
Infeed in mm	ae= 0.01xD	ae= 0.015xD	ae= 0.035xD	ae= 0.02xD	ae= 0.02xD	ae= 0.01xD	ae= 0.035xD	ae= 0.05xD	ae= 0.01xD	ae= 0.07xD
	ap= 0.01xD	ap= 0.015xD	ap= 0.035xD	ap= 0.02xD	ap= 0.02xD	ap= 0.01xD	ap= 0.035xD	ap= 0.05xD	ap= 0.01xD	ap= 0.07xD
Application										

Material	Strength (N/mm ²)	Feed (mm/Z)	Vc (m/min)	fz	fz	fz	fz	fz	fz	fz	fz	fz	
N	NON-FERROUS												
1.1	ALUMINIUM alloyed	<500	500	0.012	0.017	0.017	0.017	0.028	0.017	0.028	0.03	0.025	0.035
1.2	ALUMINIUM alloyed	<600	480	0.012	0.017	0.017	0.017	0.028	0.017	0.028	0.03	0.025	0.035
2.1-2.3	ALUMINIUM casted	<600	450	0.011	0.016	0.016	0.016	0.026	0.016	0.026	0.027	0.022	0.032
3.1-3.3	COPPER alloyed	<650	220	0.01	0.015	0.015	0.015	0.024	0.015	0.024	0.024	0.019	0.029
4.1	MAGNESIUM alloyed	<250	500	0.012	0.017	0.017	0.017	0.028	0.017	0.028	0.03	0.025	0.035
5.1	PLASTICS Thermoplastic	<100	400	0.011	0.016	0.016	0.016	0.026	0.016	0.026	0.027	0.022	0.032
5.2	PLASTICS Duroplastic	<150	350	0.01	0.015	0.015	0.015	0.024	0.015	0.024	0.024	0.019	0.029

Dimension	Ø1.8x20	Ø2x12	Ø2x40	Ø2.5x15	Ø2.5x30	Ø3x15	Ø3x45
Infeed in mm	ae= 0.05xD	ae= 0.09xD	ae= 0.01xD	ae= 0.09xD	ae= 0.035xD	ae= 0.09xD	ae= 0.02xD
	ap= 0.05xD	ap= 0.09xD	ap= 0.01xD	ap= 0.09xD	ap= 0.035xD	ap= 0.09xD	ap= 0.02xD
Application							

Material	Strength (N/mm ²)	Feed (mm/Z)	Vc (m/min)	fz	fz	fz	fz	fz	fz	fz
N	NON-FERROUS									
1.1	ALUMINIUM alloyed	<500	500	0.03	0.035	0.025	0.035	0.03	0.04	0.03
1.2	ALUMINIUM alloyed	<600	480	0.03	0.035	0.025	0.035	0.03	0.04	0.03
2.1-2.3	ALUMINIUM casted	<600	450	0.027	0.032	0.022	0.032	0.027	0.035	0.025
3.1-3.3	COPPER alloyed	<650	220	0.024	0.029	0.019	0.029	0.024	0.03	0.02
4.1	MAGNESIUM alloyed	<250	500	0.03	0.035	0.025	0.035	0.03	0.04	0.03
5.1	PLASTICS Thermoplastic	<100	400	0.027	0.032	0.022	0.032	0.027	0.035	0.025
5.2	PLASTICS Duroplastic	<150	350	0.024	0.029	0.019	0.029	0.024	0.03	0.02

NOTE | Values in the table are the shortest and the longest overhang length (L3) of each dimension; please calculate fz, ap and ae depending on the given values.



STILL CAN'T FIND A SUITABLE MILLING CUTTER?

No problem - simply customize an existing tool. Using our configurator for special milling cutters, you can customize existing tools to your needs in an instant or create your own tools based on predefined types.

WE WILL RESPOND TO ALL REQUESTS SUBMITTED VIA THE CONFIGURATOR WITHIN ONE WORKING DAY AT THE LATEST



EXPLANATION

APPLICATIONS

Multipass milling	Trimming	Deburring	Engraving
Corner rounding	Full slot milling	Forward and backward deburring	

COOLINGS

Air-cooling	Dry machining	Oil cooling	Cooling Lubricant
Minimum quantity lubrication			

FEATURES

2xD	3xD	4xD	5xD
Center cutting	Non-center cutting	Without Weldon	With Weldon
Internal cooling	Dynamic helical pitch	Chip breaker	Unequal tooth pitch
Roughing teeth	Helical immersion	Feed directions x,y	Feed directions x, y, z
Feed directions x, y, (z)			

STRATEGY

Extended Trochoidal Cutting	High Performance Cutting	High Speed Cutting	Multi Task Cutting
Universal Machining			

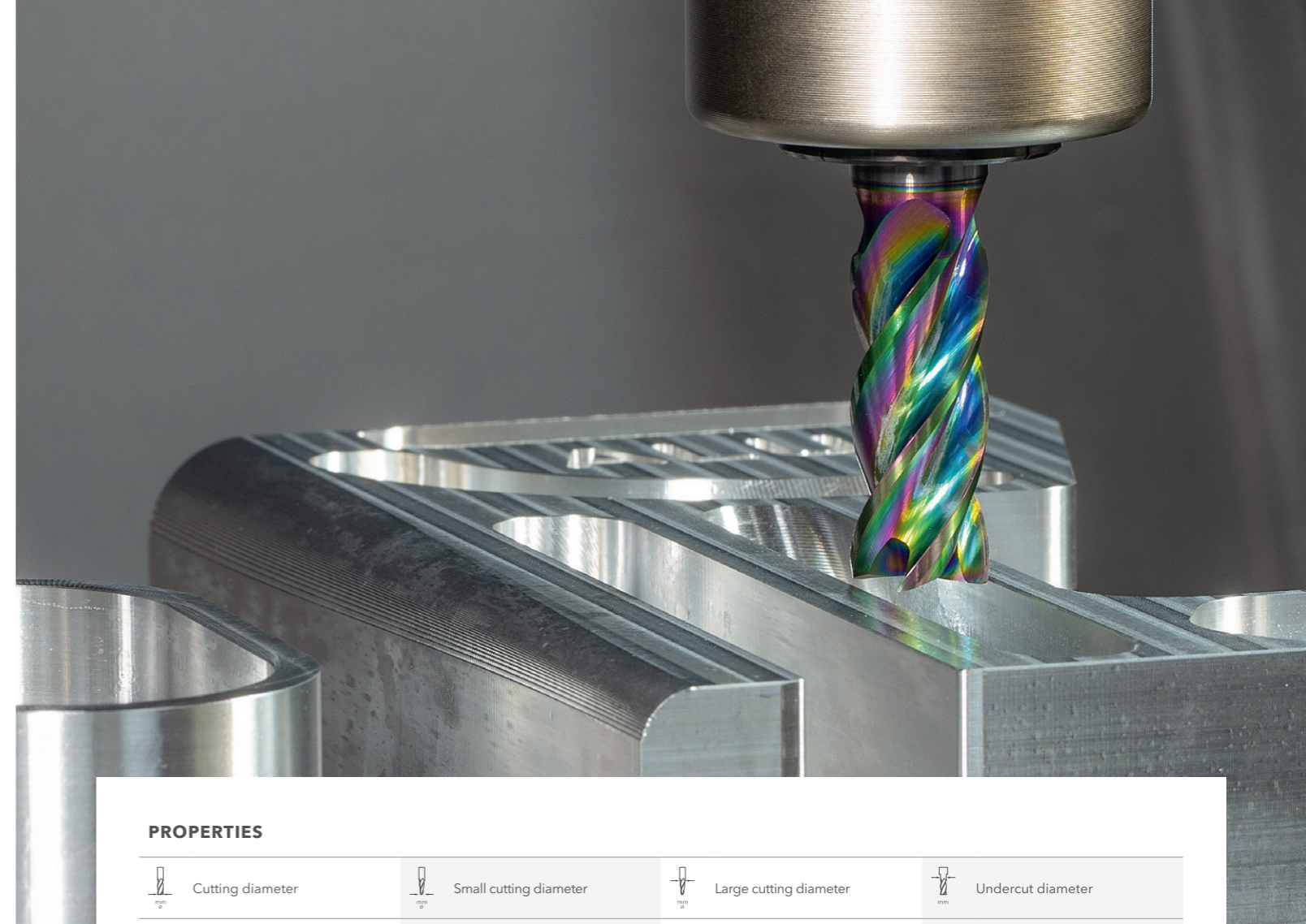

PROPERTIES

Cutting diameter	Small cutting diameter	Large cutting diameter	Undercut diameter
Length of cut	Total bevel length	Undercut length	Total length
Shank diameter	Number of teeth	Corner radius	Corner bevel
Programming radius	Maximum depth of cut	Helical angle	Alpha angle

APPLICATION TABLE

The values given in the application table are only guidelines. These values are largely dependent on the machining situation and application.

FIGURES

All technical drawings and photographs are given as an example. The product may deviate from the original in terms of colour and dimensions.

N 1.1 ALUMINIUM | alloyed <500 N/mm²

Materialnumber	Germany DIN	Europe EN	France AFNOR	Great Britain BS	Italy UNI	Sweden SIS	Spain UNE	Japan JIS	USA AISI
3.0205	Al99	AW-1200	A 4	1 C	P-Al99.0	4010	L-3001	A1200	AA1200
3.0250	Al99.5H		A 59050 C	L 31					AA1000
3.0255	Al99.5	AW-1050 A	A 5	L 31	P-AlP99.5	4007	L-3051	A1050	AA1050 A
3.0275	Al99.7	AW-1070 A	A 7	2L 48	P-AlP99.7	4005	L-3071	A1070	AA1070 A
3.0280	Al99.8								
3.0285	Al99.8	AW-1080 A	A 8	1A	P-Al99.8	4004	L-3081	A1080	AA1080 A
3.0305	Al99.9	AW-1090							
3.0505	AlMn 0.5 Mg 0.5	AW-3105		N 31				A3105	AA3105
3.0506	AlMn 0.6	AW-3207							
3.0515	AlMn 1	AW-3103		N 3	P-AlMn 1.2	4067	L-3811	A3103	AA3103
3.0517	AlMn 1 Cu	AW-3003	A-M1		P-AlMn 1.2 Cu		L-3810	A3003	AA3003
3.0525	AlMn 1 Mg 0.5	AW-3005	A-MG0,5					A3005	AA3005
3.0526	AlMn 1 Mg 1	AW-3004	A-M1G		P-AlMn 1.2 Mg	GA/6511	L-3820	A3004	AA3004
3.0915	AlFeSi	AW-8011A							
3.1255	AlCu 4 SiMg	AW-2014	A-U4SG	H 15	P-AlCu 4.4 SiMnMg		L-3130	A2014	AA2014
3.1305	AlCu 2.5 Mg	AW-2117	A-U2G	L 86	P-AlCu 2.5 MgSi		L-3180	A2117	AA2117
3.1324	AlCu 4 MgSi	AW-2017 A							
3.1325	AlCuMg1	AW-2017 A	A-U4G	H 14	P-AlCu 4.5 MgMn	GA631	L-3120	A2017	AA2017 A
3.1355	AlCuMg2	AW-2024	A-U4G1	L 97 / L 98	P-AlCu 4.5 MgMn	5	L-3140	A2024	AA2024
3.1371	G-AlCu 4 TiMg	AC-21000							
3.1841	G-AlCu 4 Ti	AC-21100							
3.2134	G-AlSi 5 Cu 1,3 Mg	AC-45300							
3.2307	Al99.85 MgSi								
3.2315	AlMgSi 1	AW-6082	A-SGM0,7	H 30	P-AlMgSi	4212	L-3453		AA6082
3.3206	AlMgSi 0.5	AW-6060	A-GS	H 9	P-AlMgSi	4140	L-3442		AA6060
3.3208	Al99.9 MgSi	AW-6401							
3.3210	AlMgSi 0.7	AW-6005 A							
3.3211	AlMg 1 SiCu	AW-6061	A-G5UC	H 20	P-AlMg 1 SiCu		L-3420	A6061	AA6061
3.3241	G-AlMg 3 Si								
3.3261	G-AlMg 5 Si	AC-51400							
3.3292	GD-AlMg 9	AC-51200							
3.3307	Al99.85 Mg 0.5	AW-5110							
3.3308	Al99.9 Mg 0.5	AW-5210							
3.3315	AlMg1	AW-5005 A	A-G0,6	N 41	P-AlMg 0.9	4106	L-3350	A5005	AA5005 A
3.3316	AlMg 1.5	AW-5050	A-G1,5	3L 44	P-AlMg 1.5		L-3380		AA5050 B
3.3317	Al99.85 Mg 1	AW-5305							
3.3318	Al99.9 Mg 1	AW-5505							
3.3326	AlMg 1.8	AW-5051 A							
3.3345	AlMg 4.5	AW-5082	A-G4,5		P-AlMg 4.4			A5082	AA5082
3.3523	AlMg 2.5	AW-5052	A-G2,5C	L 80 / L 81	P-AlMg 2.5	4120	L-3360	A5052	AA5052
3.3525	AlMg 2 Mn 0.3	AW-5251	A-G2M	N4	P-AlMg 2 Mn		L-3361		AA5251
3.3527	AlMg 2 Mn 0.8	AW-5049	A-G2,5MC					A5049	AA5049
3.3535	AlMg 3	AW-5754	A-G3M		P-AlMg 3.5	4130	L-3390		AA5754
3.3537	AlMg 2.7 Mn	AW-5454	A-G2,5MC		P-AlMg 2.7 Mn	4130	L-3391		AA5454
3.3541	G-AlMg 3	AC-51100							
3.3545	AlMg 4 Mn	AW-5086	A-G4MC		P-AlMg 4.4		L-3382		AA5086
3.3547	AlMg 4,5 Mn	AW-5083	A-G4,5MC	N 8	P-AlMg 4.5	4140	L-3321	A5083	AA5083
3.3549	AlMg 5 Mn	AW-5182							
3.3555	AlMg 5	AW-5019							
3.3561	G-AlMg 5	AC-51300							

N 1.2 ALUMINIUM | alloyed <600 N/mm²

Materialnumber	Germany DIN	Europe EN	France AFNOR	Great Britain BS	Italy UNI	Sweden SIS	Spain UNE	Japan JIS	USA AISI
3.0615	AlMgSiPb	AW-6012	A-SGPb		P-AlSiMgMn		L-3452		AA6012
3.1645	AlCu 4 PbMgMn	AW-2007				4355	L-3121	A2007	AA2007
3.1655	AlCu 6 BiPb	AW-2011	A-U5PbBi	FC 1	P-AlCu 5.5 PbBi	4338	L-3192	A2011	AA2011
3.4335	AlZn 4.5 Mg 1	AW-7020	A-Z5G	H 17		4425	L-3741		AA7020
3.4345	AlZnMgCu 0.5	AW-7022	A-Z4GU						AA7022
3.4365	AlZnMgCu 1.5	AW-7075	A-Z5GU	2L 95	P-AlZn 5.8 MgCu		L-3710	A7075	AA7075

N 2.1 - N 2.3 ALUMINIUM | casted <600 N/mm²

Materialnumber	Germany DIN	Europe EN	France AFNOR	Great Britain BS	Italy UNI	Sweden SIS	Spain UNE	Japan JIS	USA AISI
3.1841	G-AlCu 4 Ti							AC1A	A 295.0
3.1871	G-AlCu 4 TiMg								
3.2131	G-AlSiCu1								
3.2151	G-AlSi 6 Cu 4	AC-45000	A-S5UZ	LM 4				AC4B	A 319.0
3.2161	G-AlSi 8 Cu 3	AC-46200	A-S9U3A-Y4	LM 24	5075			AC4D	A 328.0
3.2163	GD-AlSi 9 Cu 3								
3.2211	G-AlSi 11								
3.2341	G-AlSi 5 Mg								
3.2371	G-AlSi 7 Mg 0,3	AC-42100						AC4CH	A 356.0
3.2373	G-AlSi 9 Mg	AC-43300							
3.2381	G-AlSi 10 Mg	AC-43100							
3.2382	GD-AlSi 10 Mg								
3.2383	G-AlSi 10 Mg(Cu)	AC-43400	A-S10G	LM 9	3049	4253		ADC3	A 360.2
3.2581	G-AlSi 12	AC-47100	A-S13	LM 6	4514	4261		AC3A	A 413.2
3.2582	GD-AlSi 12					4247		ADC1	A 413.0
3.2583	G-AlSi 12 Cu	AC-44300	A-S12-Y4	LM 20	5079	4260		ADC1	A 413.1
3.2585	SG-AlSi12								
3.2982	GD-AlSi 12 Cu								
3.3241	G-AlMg 3 Si								
3.3261	G-AlMg 5 Si							AC7A	A 514.0
3.3561	G-AlMg 5								

N 3.1 COPPER | alloyed <600 N/mm²

Materialnumber	Germany DIN	Europe EN	France AFNOR	Great Britain BS	Italy UNI	Sweden SIS	Spain UNE	Japan JIS	USA AISI
2.0060	E-Cu 57	CW-004A							B-120
2.0065	E-Cu 58	CW-004A	Sn-a2	C 101					C 11000
2.0070	SE-Cu	CW-020A	Cu-c1	C 101					C 10300
2.0082	G-Cu L 45			HCC 1					C 81100
2.0085	G-Cu L 50	CC-040A		HCC 1					C 81100
2.0240	CuZn 15	CW-502L	CuZn 15	CZ 102				C 2300	C 23000
2.0265	CuZn 30	CW-505L	CuZn 30	CZ 102				C 2600	C 26000
2.0321	CuZn 37	CW-508L	CuZn 37	CZ 180	C 2720				C 27200
2.0340	G-CuZn 37 Pb	CC-7545-GM							
2.0492	G-CuZn 15 Si 4	CC-7615-GS							B-198
2.0592	G-CuZn 35 Al 1	CC-7655	U-Z 36 N 3	HTB 1					C 86500
2.0595	G-KCuZn 37 Al 1	CC-7665							
2.0596	G-CuZn 34 Al 2	CC-7645	U-Z 36 N 3						
2.0857	CuNi 3 Si	CW-112C							
2.0916	CuAl 5								
2.0927	SG-CuAl 9 Ni 5 Fe								
2.0936	CuAl 10 Fe 3 Mn 2	CW-306G	U-A 10 Fe	CA 103					
2.0966	CuAl 10 Ni 5 Fe 4	CW-307G	U-A 10 N	CA 104					C 63000
2.1006	SG-CuSn								
2.1050	G-CuSn 10	CC-480K-GS		CT 1					C 90700
2.1052	G-CuSn 12	CC-483K-GS	UE 12 P	Pb 2					C 91700
2.1060	G-CuSn 12 Ni 2	CC-484K-GS							C 91700
2.1090	G-CuSn 7 ZnPb		UE 7 Z5 Pb 4						C 93200
2.1093	G-CuSn 6 ZnNi			LG 4					
2.1096	G-CuSn 5 ZnPb		UE 5 Pb 5 Z 5	LG 2					C 83600
2.1176	G-CuPb 10 Sn	CC-495K-GS	UE 10 Pb 10	LB 2					C 93700
2.1182	G-CuPb 15 Sn	CC-496K-GS	U-Pb 15 E 8	LB 1					C 93800
2.1188	G-CuPb 20 Sn	CC-497K-GS	U-Pb 20	LB 5					C 94100
2.1266	CuCd 1								
2.1292	G-CuCrF 35	CC-140C		CC1-FF					C 81500
2.1293	CuCrZr	CW-106C	U-Cr 0.8 Zr	CC 102					C 81500
2.1322	CuMg 0.4								
2.1355	CuMn 2								
2.1461	SG-CuSi 3	CW-116C							

N 4.1 MAGNESIUM | alloyed <200 N/mm²

Materialnumber	Germany DIN	Europe EN	France AFNOR	Great Britain BS	Italy UNI	Sweden SIS	Spain UNE	Japan JIS	USA AISI
3.5101	G-MgZn 4 SE1 Zr 1	MC-35110	G-Z 4 Tr	MAG-5					ZE 41
3.5102	G-MgZn 5 Th2 Zr1								
3.5103	MgSE 3 Zn2 Zr1	MC-65120	G-Tr 3 Z 2	MAG-6					EZ 33
3.5105	G-MgTh 3 Zn2 Zr1								QE 22
3.5106	G-MgAg 3 SE2 Zr1	MC-65210	G-Ag 22.5	MAG-12					
3.5200	G-MgAl 8 Zn 1	MA-40020							
3.5312	MgAl 3 Zn	MA-21130							
3.5314	MgAl 3 Zn		G-A3 Z1	MAG-E-111					AZ 31 B
3.5470	GD-MgAl 4 Si 1	MC-21320							
3.5612	GD-MgAl 6 Zn 3	MC-21140							
3.5614	MgAl 6 Zn		G-A6 Z1	MAG-E-121					AZ 61 A
3.5662	GD-MgAl 6								
3.5812	G-MgAl 8 Zn 1	MC-21110	G-A9						AZ 81
3.5912	G-MgAl 9 Zn 1	MC-21120	G-A 9 Z 1						AZ 91

N 5.1 PLASTICS | thermoplastics <100 N/mm²

Materialnumber	Germany DIN	Europe EN	France AFNOR	Great Britain BS	Italy UNI	Sweden SIS	Spain UNE	Japan JIS	USA AISI
PC	Makralon		Orgalan	Sinvet					Lexan
PC	Nuclon								Merlon
PC	Plastocarbon								
PE	Baylon			Fertene	Carlona				Althon
PE	Dekalen			Eraclene	Escorene				Bakelite
PE	Lupolen								Chemplex
PE	Hostalen								Dylan
PF	Alberit			Fenachem					Biralit
PF	Bakelit			Moldesile					Biratex
PF	Bulitol								Birax
PF	Durax								
PF	Harex								
PF	Resinol								
PFTE	Hostafflon		Sorefflon						Halon; Teflon
PP	Vestolen PP		Eitex P	Moplen	Carola P				Profax
PP	Synalen PP		Napryl	Kastilen	Procom				Rexene
PP	Novolen								Tenite
PP	Hostalen PP								
PS	Hostylon			Sdistir	Lustrex				Carinex
PS	Lorkalen			Lastinol					Dylene
PS	Polystyrol								Toporex
PS	Styropor								
PVC	Coroplast								
PVC	Hostalit								
PVC	Mipolam								
PVC	Opalon								
PVC	Solvec								
PVC	Vinoflex								
PP-H	Homopolymer								
PP-C	Copolymer								
ABS	Acrylnitrid Butadien Styrol								
PMMA	Polymethyl metha Crylat								
PMMA	Plexiglas; Resarit; Degluan								
POMC	Polyoxymethylen								
POMC	Hostaform; ultraform								
PI	Polymid								
PEI	Polytherimid								
PVC-H	Polyvinylchlorid (hard)								
PA	Polyamide								

N 5.2 PLASTICS | duroplastics <150 N/mm²

Materialnumber	Germany DIN	Europe EN	France AFNOR	Great Britain BS	Italy UNI	Sweden SIS	Spain UNE	Japan JIS	USA AISI
PUR 5220									
PF 31									
MP 183									

Technical formulas

Calculate cutting speed (m/min)

$$V_c = \frac{D \cdot \pi \cdot n}{1000}$$

Calculate rotational speed (rpm)

$$n = \frac{V_c \cdot 1000}{D \cdot \pi}$$

Calculate feed rate (mm/min)

$$V_f = n \cdot z \cdot f_z$$

Calculate feed per tooth (mm/number of teeth)

$$f_z = \frac{V_f}{n \cdot z}$$

Calculate chip removal rate (cm³/min)

$$Q = \frac{a_p \cdot a_e \cdot V_f}{1000}$$

Calculate average chip thickness (mm)

$$h_m = f_z \cdot \frac{\sqrt{a_e}}{D}$$

Explanation of terms

V _c	Cutting speed	in m/min
n	Rotational speed	in rpm
V _f	Feed rate	in mm/min
F _z	Feed per tooth	in mm/number of teeth
z	Number of teeth (cutting)	
a _p	Depth of cut	in mm
a _e	Width of cut	in mm
h _m	Average chip thickness	in mm
Q	Chip removal rate	in cm ³ /min
D	Diameter of tool	in mm

GENERAL TERMS OF SALE

§ 1 SCOPE

1. These General Terms of Sale apply to all business relationships between Hofmann & Vratny OHG (hereinafter referred to as “Hofmann & Vratny”) and its customers (hereinafter referred to individually as the “Ordering Party” and collectively as the “Ordering Parties”).

2. These General Terms of Sale only apply to Ordering Parties that are entrepreneurs pursuant to §§ 14 and 310 para. 1 of the BGB (Civil Code of Germany), legal entities under public law, and/or special funds under public law.

3. The scope of application of these General Terms of Sale includes, but is not limited to, contracts regarding the sale and/or delivery of chattels (hereinafter referred to as “Goods”) regardless of whether they are produced by Hofmann & Vratny or procured from suppliers (§§ 433 and 651 of the BGB). Unless agreed upon otherwise, the version of these General Terms of Sale applicable at the time the Ordering Party places an order and in any case the most recent version of these General Terms of Sale provided to the Ordering Party in writing in the form of a master agreement also shall apply to similar contracts made at a later date without Hofmann & Vratny being required to make reference to them in every individual case.

4. These General Terms of Sale shall apply exclusively. These General Terms of Sale also shall apply if and when Hofmann & Vratny executes a delivery without reservation despite having knowledge of the Ordering Party’s terms of sale which contradict or deviate from these General Terms of Sale. Any of the Ordering Party’s terms of sale which contradict or deviate from these General Terms of Sale shall become part of a contract only with Hofmann & Vratny’s express prior consent. Such requirement to consent shall apply in any case even, for example, if the Ordering Party refers to its terms of sale as part of an order placement and Hofmann & Vratny does not object explicitly to such terms.

5. If Hofmann & Vratny and the Ordering Party have entered into any individual agreements, such individual agreements shall prevail over these General Terms of Sale. The content of such individual agreements only can be substantiated by a written contract or by written confirmation from Hofmann & Vratny. Individual agreements (e.g., outline delivery contracts, quality assurance agreements) and information provided in Hofmann & Vratny’s order confirmation shall prevail over these General Terms of Sale. In case of doubt, commercial clauses shall be interpreted based on the Incoterms® issued by the International Chamber of Commerce in Paris (ICC) and applicable at the time the contract is entered into.

6. All of the Ordering Party’s legal declarations and notifications made with regard to the contract (e.g., in connection with deadlines or notices of defects, rescission, or reduction) shall be made in writing to be effective. In the context of these General Terms of Sale, in writing shall include written and text forms (e.g., letters, e-mails, faxes). Legal requirements regarding form and other verifications including, but not limited to, cases of doubt regarding the legitimation of the notifying party shall remain unaffected.

7. All references to applicable laws shall be for the purpose of clarification only. Unless amended in or excluded expressly from these General Terms of Sale, laws shall apply even without express reference.

§ 2 OFFERS AND ACCEPTANCE

1. All offers made by Hofmann & Vratny shall be subject to change and shall be non-binding including if and when images, drawings, technical documentation, calculations, analyses, other documents or product descriptions of whatever nature (hereinafter referred to as “Documents”) are provided to the Ordering Party if the proprietary rights and copyrights to those Documents are retained by Hofmann & Vratny.

2. All orders for Goods placed by the Ordering Party shall constitute binding offers. Unless stated otherwise in the respective order, Hofmann & Vratny shall be entitled to accept an offer within two weeks after receipt of said offer.

3. Hofmann & Vratny shall accept offers in writing (e.g., in the form of an order confirmation) or by delivering the respective Goods to the Ordering Party.

4. All proprietary rights and copyrights to Documents shall remain with Hofmann & Vratny. Documents marked as confidential shall be forwarded to third parties only with the express written consent of Hofmann & Vratny.

§ 3 DELIVERY DEADLINES AND DEFAULT OF DELIVERY

1. Delivery deadlines shall be agreed upon by Hofmann & Vratny and the individual Ordering Party or shall be specified by Hofmann & Vratny upon acceptance of the order or in the order confirmation.

2. Hofmann & Vratny’s compliance with delivery obligations shall be conditional upon the Ordering Party’s on-time and proper compliance with the Ordering Party’s obligations including, but not limited to, the provision of the papers, permits and approvals required to be provided by the Ordering Party and the receipt by Hofmann & Vratny of the agreed-upon down payment, if any. In the event of delays, the delivery time shall be extended reasonably.

3. If Hofmann & Vratny is unable to meet any binding delivery deadlines for reasons beyond the control of Hofmann & Vratny (non-availability of services), the Ordering Party shall be notified without undue delay and shall be provided with an estimated new delivery deadline. If the agreed upon Goods do not become available before the new deadline expires, Hofmann & Vratny shall be entitled to rescind the contract in whole or in part and shall reimburse the Ordering Party without undue delay for any and all consideration paid up to that time. For the fulfillment of this clause, non-availability of services shall include, but shall not be limited to, delayed delivery from any of Hofmann & Vratny’s suppliers for reasons beyond the control of Hofmann & Vratny or its suppliers, or if Hofmann & Vratny is not responsible for procuring the Goods.

4. If failure to comply with a delivery deadline is due to an act of God, industrial dispute or other event beyond the control of Hofmann & Vratny, the delivery time shall be extended reasonably. The same shall apply if and when any such act of God, industrial dispute or other event has arisen at any of Hofmann & Vratny’s sub-suppliers which event can be demonstrated to have had an impact on compliance with the delivery deadline. Hofmann & Vratny shall notify the Ordering Party of such circumstances without undue delay. Events also shall be deemed to be beyond Hofmann & Vratny’s control if and when they occur during a delay. In this case, the delay shall be deemed to be suspended for the duration of the respective event.

5. The beginning of a period of delivery default shall be in accordance with the law, but shall in any case require a reminder issued by the Ordering Party.

6. If a contract regarding stand-by delivery has been signed, Hofmann & Vratny shall deliver and invoice the Goods no later than 12 months after the date of such contract (hereinafter referred to as the “Recall Period”), even if the Ordering Party has failed to recall the Goods by that time. After the Recall Period has expired, Hofmann & Vratny can notify the Ordering Party of Hofmann & Vratny’s readiness to deliver and can request that the Ordering Party recall the Goods within a reasonable period of time. If the Ordering Party fails to recall the Goods within such period, Hofmann & Vratny shall be entitled to demand an additional lumpsum compensation for warehousing costs (hereinafter referred to as the “Warehousing Allowance”). The Warehousing Allowance shall be 0.5% of the net value of the purchased Goods for every full week, but shall not exceed 5% of the net value of the purchased Goods in total. The Ordering Party shall be free to prove that Hofmann & Vratny did not incur any damages or that any damages incurred were lower than the Warehousing Allowance. If the Ordering Party fails to recall the Goods within the Recall Period determined by Hofmann & Vratny, Hofmann & Vratny shall be entitled to dispose of the Goods as Hofmann & Vratny sees fit. The statutory provisions regarding rescission shall remain unaffected.

§ 4 DELIVERY AND DEFAULT OF ACCEPTANCE

1. Unless agreed upon otherwise, all deliveries shall be ex works, that is, the

place of performance for deliveries and for all subsequent actions. Unless agreed upon otherwise, upon request and at the expense of the Ordering Party the Goods shall be delivered to another destination (hereinafter referred to as “Sales Involving the Carriage of Goods”). Unless agreed upon otherwise, Hofmann & Vratny shall be entitled to determine the shipment method (including, but not limited to, the forwarder, the type of shipment and the packaging).

2. Partial deliveries shall be admissible, provided the Ordering Party reasonably can be expected to accept them.

3. Delivered Goods shall be accepted by the Ordering Party even if the delivered Goods have minor defects provided the Ordering Party reasonably can be expected to accept such Goods.

4. The risk of accidental destruction and/or deterioration of the Goods shall transfer to the Ordering Party no later than upon surrender of the Goods. In the case of Sales Involving the Carriage of Goods, the risk of accidental destruction and/or deterioration of the Goods and the risk of delay shall transfer to the Ordering Party no later than at the time of delivery of the Goods to the forwarder, carrier, or any other person designated to execute shipment of the Goods. Delivery shall be deemed to have been effected even if the Ordering Party is in default of acceptance.

5. If the Ordering Party is in default of acceptance or fails to cooperate or if delivery is delayed for other reasons for which the Ordering Party is responsible, Hofmann & Vratny shall be entitled to demand reimbursement for the damages incurred in connection therewith including additional expenses (e.g., warehousing costs).

§ 5 TERMS OF PAYMENT

1. Unless agreed upon otherwise in individual cases, Hofmann & Vratny’s prices plus statutory sales tax valid at the time the contract is signed shall apply. The prices indicated in Hofmann & Vratny’s catalogs are non-binding and subject to change and/ or correction.

2. Unless agreed upon otherwise, in the case of Sales Involving the Carriage of Goods the Ordering Party shall bear the costs of packaging and transportation ex works and the costs, if any, for transportation insurance if such insurance is requested by the Ordering Party. All customs and other fees, taxes and other public charges also shall be borne by the Ordering Party unless agreed upon otherwise. Ownership of the packaging for transportation and otherwise pursuant to the Verpackungsordnung (Packaging Ordinance of Germany) shall transfer to the Ordering Party and such packaging shall not be returned to Hofmann & Vratny. Pallets shall be exempt from this rule.

3. Unless agreed upon otherwise in the order confirmation, the purchase price plus statutory sales tax shall be due and payable without any deductions within 14 days after the date of invoicing and delivery or acceptance of the Goods. However, Hofmann & Vratny reserves the right to make full or partial deliveries against cash in advance at any time including during an ongoing business relationship. The assertion of such right shall be communicated no later than at the time the order confirmation is issued. The Ordering Party shall be deemed to be in default of payment upon the expiration of the aforementioned payment deadline. The applicable rate of interest on the purchase price of the Goods shall become payable during the default period. The right to assert claims for more substantial compensation shall be reserved. Hofmann & Vratny’s right to claim commercial-rate default interest (§ 353 of the HGB) shall remain unaffected.

4. The Ordering Party’s rights of set-off and retention shall be limited to the extent the Ordering Party’s claim is determined in a court of law or is undisputed. The Ordering Party’s rights based on defects in the purchased Goods (see § 7 hereof) shall remain unaffected.

5. After the contract has been signed, if there is evidence that Hofmann & Vratny’s claim to the purchase price will be compromised due to lack of performance on the part of the Ordering Party, Hofmann & Vratny shall be entitled to refuse performance pursuant to the applicable laws and, after setting a deadline, if applicable, shall be entitled to rescind the contract. In the case of contracts regarding the production of customized items, Hofmann & Vratny shall be entitled to rescind the contract immediately and the laws regarding the expendability of setting deadlines shall remain unaffected.

§ 6 RETENTION OF TITLE

1. Until all pending and future receivables in connection with the business relationship between Hofmann & Vratny and the Ordering Party are paid in full, Hofmann & Vratny shall retain ownership of the Goods. If the Ordering Party violates the contract including, but not limited to, default of payment, Hofmann & Vratny shall be entitled to rescind the contract pursuant to the applicable laws and to demand the surrender of the Goods.

2. Goods subject to retention of title shall not be pledged or assigned as collateral before the Ordering Party has paid in full. The Ordering Party shall notify Hofmann & Vratny in writing without undue delay in the event of a filing for commencement of insolvency proceedings or if third parties gain access (e.g., seizures) to Goods belonging to Hofmann & Vratny.

3. If the Ordering Party violates the contract including, but not limited to, by failing to pay the purchase price when due, Hofmann & Vratny shall be entitled to rescind the contract pursuant to the applicable laws and to demand the surrender of the Goods due to the retention of title and the rescission.

4. Until further notice, the Ordering Party shall be entitled to resell/and or process in the ordinary course of business any Goods subject to retention of title. In this case, the provisions below also shall apply.

a) The retention of title shall include title to the full value of work products resulting from processing, mixing or combining the Goods, in which case Hofmann & Vratny shall be deemed to be the manufacturer. If and when third-party goods are processed, mixed or combined and such third parties retain ownership, Hofmann & Vratny shall acquire coownership pro rata of the invoiced value of work products so processed, mixed or combined. In all other cases, the creation of work products shall be subject to the same provisions as the delivered Goods subject to retention of title.

b) The Ordering Party hereby agrees to assign to Hofmann & Vratny as collateral any and all receivables against third parties resulting from the resale of the Goods or work results in full or in the amount of Hofmann & Vratny’s estimated share of co-ownership pursuant to a) above, and Hofmann & Vratny hereby accepts such assignment. The Ordering Party’s obligations under § 6 2) hereof also shall apply with respect to the receivables assigned.

c) In addition to Hofmann & Vratny, the Ordering Party shall remain authorized to collect receivables. Hofmann & Vratny undertakes to refrain from collecting receivables as long as the Ordering Party meets its payment obligations vis-à-vis Hofmann & Vratny and does not fail to perform and Hofmann & Vratny does not assert its retention of title by asserting a right under § 6 3) hereof. Otherwise, Hofmann & Vratny shall be entitled to demand that the Ordering Party inform Hofmann & Vratny of such receivables assigned and of the names of the debtors, provide Hofmann & Vratny with all the information required for collecting such receivables and the pertinent documents, and inform the debtors (third parties) of the assignment. In addition, in this case Hofmann & Vratny shall be entitled to revoke the Ordering Party’s authorization to resell and/or process Goods which are subject to retention of title.

5. Upon request of the Ordering Party, Hofmann & Vratny shall release the collateral to which Hofmann & Vratny is entitled insofar as the realizable value of such collateral exceeds the receivables to be collateralized by more than 10 percent. Hofmann & Vratny shall be free in its decision regarding which collateral to release.

§ 7 LIABILITY FOR DEFECTS AND CLAIMS FOR DEFECTS

1. Unless otherwise agreed upon herein, the Ordering Party’s rights based on defects in quality and/or in title (including delivery of the wrong Goods or insufficient amounts, improper assembly/installation, or incomplete instructions) shall be subject to the applicable laws. The special legal stipulations regarding reimbursement of expenses at the time of delivery of newly produced Goods (supplier’s recourse as specified in §§ 478, 445a, 445b and §§ 445c, 327 para. 5, 327u of the BGB) shall remain unaffected in any case, unless equal-value compensation has been agreed upon, for example, as part of a quality assurance agreement.

2. Hofmann & Vratny’s liability for defects shall be based first and foremost on the respective agreement entered into regarding the quality and the posulated use of the Goods (including fittings and instructions). In this context,

an agreement regarding the quality of Goods shall be any and all product descriptions and manufacturer-provided information outlined in the individual agreement or made publicly known by Hofmann & Vratny (including, but not limited to, in catalogs or on Hofmann & Vratny's internet homepage) at the time the contract was signed. However, if and when no agreement regarding quality has been entered into, the presence or absence of a defect shall be determined based on the legal regulations (§ 434 para. 3 of the BGB). Statements made publicly by the manufacturer or on the manufacturer's behalf including, but not limited to, in advertising materials or on labels on the Goods shall prevail over other third parties' statements. In the case of Goods comprising digital elements or other digital content, Hofmann & Vratny shall be responsible for providing and, if required, updating the digital content only if defined expressly in an agreement regarding the quality of Goods, as stipulated above. Hofmann & Vratny shall not assume any liability for public statements made by the manufacturer or other third parties.

3. Hofmann & Vratny shall not assume liability for any defects of which the Ordering Party is aware, or for any defects of which the Ordering Party is grossly negligent if it is not aware (§ 442 of the BGB) at time the contract is signed. The assertion of claims by the Ordering Party regarding defects shall be conditional upon the Ordering Party's meeting of its statutory duty to inspect and to give notice of defects (§§ 377 and 381 of the HGB (Commercial Code of Germany)). If a defect in the Goods becomes apparent during or after inspection, the Ordering Party shall give written notice to Hofmann & Vratny without undue delay. Regardless of the Ordering Party's duty to inspect and to give notice of defects, the Ordering Party shall give written notice of obvious defects within two weeks after delivery, which notice shall be deemed to have been given in a timely manner if it is transmitted before the end of such period. If the Ordering Party fails to inspect the Goods properly and/or to give proper notice of any defects, Hofmann & Vratny shall not assume liability for any defects for which no notice was given.

4. If any of the Goods are defective, Hofmann & Vratny shall be free to offer supplementary action to remedy the defect or defects (supplementary remedy) or to deliver defect-free Goods (replacement) to the Ordering Party. In individual cases, the Ordering Party may refuse a supplementary action selected by Hofmann & Vratny that the Ordering Party considers to be unreasonable. It is Hofmann & Vratny's right to refuse to offer supplementary action under the applicable laws shall remain unaffected. The requirement for Hofmann & Vratny to provide any supplementary action owed shall be conditional upon the Ordering Party's paying of the purchase price when due. However, the Ordering Party shall be entitled to retain a reasonable portion of the purchase price pro rata in consideration of the defect. The Ordering Party shall give Hofmann & Vratny the time and the opportunity to provide the supplementary action owed including, but not limited to, providing Hofmann & Vratny the opportunity to inspect the Goods which are subject to complaint. If Hofmann & Vratny opts to replace the Goods, at Hofmann & Vratny's request the Ordering Party shall return the defective Goods to Hofmann & Vratny in accordance with the applicable laws; however, the Ordering Party shall not have the right to request to return the defective Goods. Supplementary action shall not include the disassembly, removal, or de-installation of defective Goods nor the assembly, mounting, or installation of defect-free Goods, provided Hofmann & Vratny was not originally obligated to provide such services; any rights the Ordering Party may have to be reimbursed for such costs (hereinafter referred to as "Disassembly and Assembly Costs") shall remain unaffected.

5. If in fact a defect is present, any and all expenses incurred in connection with inspections and supplementary action including, but not limited to, transportation, road, labor and material costs, and Disassembly and Assembly Costs shall be borne by Hofmann & Vratny in accordance with the laws and these General Terms of Sale. However, if the Ordering Party's demand for remedy of a defect is proven to be invalid because the Ordering Party was aware or was grossly negligent if it was not aware that no defect actually was present, Hofmann & Vratny can demand reimbursement from the Ordering Party for any costs incurred therewith. If the costs of supplementary remedy would be disproportionately high, the Ordering Party shall not be entitled to claim remedy of defects.

6. If and when a reasonable deadline for supplementary action set by the buyer has expired unsuccessfully or can be disregarded under the law, the Ordering Party can rescind the purchasing contract in accordance with the law or reduce the purchase price. However, no right to rescind shall apply in the case of insignificant defects.

7. The Ordering Party's claims for damages or reimbursement for wasted expenses shall be limited by the provisions of § 8 below and shall be excluded in all other cases.

8. The statute of limitations for claims for defects in quality and in title shall be one year after delivery of the Goods. The statute of limitations shall commence upon delivery of the Goods provided acceptance has been agreed upon. Other special legal stipulations regarding statutes of limitations (including, but not limited to, § 438 para. 1 no. 1, no. 2, para. 3, §§ 444, 445b of the BGB) shall remain unaffected. The aforementioned statutes of limitations specified in the purchasing laws also shall apply to any contractual and extra-contractual claims for reimbursement made by the Ordering Party based on a defect in the Goods, unless applying the regular statute of limitations stipulated by law (§§ 195, 199 of the BGB) would result in a reduced statute of limitations in individual cases. Any claims for reimbursement the Ordering Party may have pursuant to § 8 para. 2 p. 1 and p. 2 (a) and pursuant to the Produkthaftungsgesetz (Product Liability Act of Germany) shall be subject exclusively to the statutes of limitations stipulated by law.

§ 8 OTHER LIABILITIES

1. Unless agreed upon otherwise in these General Terms of Sale and in the provisions below, Hofmann & Vratny's liability for breach of contractual and non-contractual obligations shall be in accordance with the applicable laws.

2. Hofmann & Vratny's liability for damages, regardless of the legal reasons and of whether or not they are known, as part of Verschuldenshaftung (liability arising from damage caused by negligent act) shall include intent and gross negligence. Subject to the limitations of liability stipulated by law (e.g., diligence with its own affairs, insignificant breach of duty), in the event of minor negligence Hofmann & Vratny's liability shall be limited to (a) damages resulting from harm to life, body or health and/or (b) damages resulting from the not-insignificant breach of a material contractual obligation, that is, an obligation which must be met to make the proper fulfillment of the contract possible and the meeting of which the Ordering Party relies upon and can rely upon on a regular basis. In this case, however, Hofmann & Vratny's liability shall be limited to reimbursement of the foreseeable damages typical in such cases.

3. The limitation of liability specified above also shall apply vis-à-vis third parties and in the event of a breach of duty by any person (including to his/her own benefit) for which Hofmann & Vratny is responsible by law; however, it shall not apply if and when Hofmann & Vratny is found to have failed to disclose a defect maliciously or has assumed a guarantee for the quality of the Goods and for the Ordering Party's claims under the Produkthaftungsgesetz.

4. The Ordering Party can rescind or cancel a contract due to a breach of obligation other than a breach based on a defect only if and when Hofmann & Vratny is responsible for such breach of obligation. The Ordering Party shall not have an unrestricted right to terminate a contract. All other cases shall be subject to the applicable laws and legal consequences.

§ 9 APPLICABLE LAW AND JURISDICTION

1. These General Terms of Sale and all legal relationships between Hofmann & Vratny and the Ordering Party shall be subject to the laws of the Federal Republic of Germany under exclusion of the provisions of uniform international law. The CISG shall not apply.

2. Any and all disputes arising directly or indirectly from the contractual relationship shall be subject exclusively, including at an international level, to the jurisdiction of Aßling if the Ordering Party is a businessperson as defined in the Handelsgesetzbuch (Commercial Code of Germany), a legal entity under public law, or a special fund under public law. The same shall apply if the Ordering Party is an entrepreneur pursuant to §§ 14 of the BGB. However, in any case Hofmann & Vratny shall be entitled to sue the Ordering Party at the place of performance of the obligation to deliver under these General Terms of Sale and/or under a prevailing individual agreement or at the Ordering Party's general jurisdiction. Prevailing legal regulations including, but not limited to, regarding exclusive jurisdictions, shall remain unaffected.

Hofmann & Vratny OHG
June 2022

CONTACT HOFMANN & VRATNY

Hofmann & Vratny OHG - Headquarters

Steinkirchen 4½

85617 Aßling

Telephone: +49 80 92 / 85 333-0

E-Mail: info@vhmhv.de

Hofmann & Vratny OHG - Regrinding centre

Poststr. 15a

90471 Nürnberg

Telephone: +49 80 92 / 85 333-152

E-Mail: nbg@vhmhv.de

A RELIABLE PARTNER

DISCOVER OUR H&V PRODUCT RANGE.

Our goal is to provide companies around the world with the best tools.

We are constantly developing our product portfolio. We experiment with new geometries, coatings and materials at our research and development center to make the right milling cutters for every application.

SCAN THE QR CODE NOW



EXPERT | Steel & cast iron



EXPERT | Stainless steel



EXPERT | Titanium



EXPERT | Hardened steel

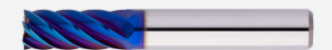

BASIC | Universal





Expert

2022

EN

HOFMANN & VRATNY EXN1 SERIES - EXPERTS IN CUTTING NON-FERROUS MATERIALS

Hofmann & Vratny OHG

Steinkirchen 4½

85617 Aßling

Telephone: +49 80 92 / 85 333-0

E-Mail: info@vhmhv.de

Web: www.vhmhv.de

OFFICIAL PARTNER OF H&V



 **SolidCAM**
The Leaders in Integrated CAM

Die einzigartige, revolutionäre Frästechnologie
imachining[®]
patent by SolidCAM